



City of Hamilton

GENERAL ISSUES COMMITTEE REVISED

Meeting #: 19-014
Date: August 12, 2019
Time: 9:30 a.m.
Location: Council Chambers, Hamilton City Hall
71 Main Street West

Stephanie Paparella, Legislative Coordinator (905) 546-2424 ext. 3993

1. CEREMONIAL ACTIVITIES

2. APPROVAL OF AGENDA

(Added Items, if applicable, will be noted with *)

3. DECLARATIONS OF INTEREST

4. APPROVAL OF MINUTES OF PREVIOUS MEETING

4.1 July 8, 2019

5. COMMUNICATIONS

6. DELEGATION REQUESTS

6.1 Michael Van Pelt, Cardus, respecting a forthcoming staff report regarding the Balfour House (For the September 4, 2019 GIC))

*6.2 P.J. Mercanti, S. Jasper Kujavsky, Greg Maychak and Mark Wu, Hamilton100 Commonwealth Games Bid Corporation, respecting the Commonwealth Games (For the August 12th GIC)

*6.3 David Bennett, Hamilton 350, respecting Items 10.3 and 10.4 on the August 12, 2019 GIC Agenda, as they Relate to Climate Change (For the August 12th GIC)

7. CONSENT ITEMS

- 7.1 Revised Board of Management for the Concession Street Business Improvement Area (BIA) (PED19155) (Wards 7 and 8)
- 7.2 Revised Board of Management for the Locke Street Business Improvement Area (BIA) (PED19156) (Ward 1)
- 7.3 Revised Board of Management for the Barton Village Business Improvement Area (BIA) (PED19160) (Wards 2 and 3)
- 7.4 Advisory Committee for Persons with Disabilities Minutes 19-005, June 11, 2019

8. PUBLIC HEARINGS / DELEGATIONS**9. STAFF PRESENTATIONS****10. DISCUSSION ITEMS**

- 10.1 Hamilton-Wentworth District School Board Liaison Committee Report 19-002, June 27, 2019
- 10.2 Business Improvement Area Advisory Committee Report 19-007, July 9, 2019
- 10.3 GRIDS 2 and Municipal Comprehensive Review – Work Plan Update (PED17070(d))
- 10.4 Memorandum of Understanding City of Hamilton and Hamilton100 Commonwealth Games Bid Corporation (PED19108(a)) (City Wide)
- 10.5 Environmental Remediation and Site Enhancement (ERASE) Redevelopment Grant Application, 1160 Main Street East, ERG19-01 (PED19153) (Ward 3)
- 10.6 Advisory Committee for Persons with Disabilities Report 19-006, July 9, 2019
- 10.7 Policies and Procedures for Hate Mitigation (CM19006) (City Wide)

11. MOTIONS**12. NOTICES OF MOTION**

13. GENERAL INFORMATION / OTHER BUSINESS

13.1 Items to be referred:

13.1.a Benefit Plan Redesign

(Be referred to the Non-Union Compensation Sub-Committee)

13.2 Items to be removed:

13.2.a Memorandum of Understanding City of Hamilton and Hamilton 100 Commonwealth Games Bid Corporation

(Addressed as Item 10.4 on this agenda – Report PED19108(a))

14. PRIVATE AND CONFIDENTIAL

14.1 Closed Session Minutes - July 8, 2019

Pursuant to Section 8.1, Sub-sections (c), (e) and (f) of the City's Procedural By-law 18-270, and Section 239(2), Sub-sections (c), (e) and (f) of the *Ontario Municipal Act*, 2001, as amended, as the subject matters pertain to a proposed or pending acquisition or disposition of land; litigation or potential litigation, including matters before administrative tribunals, affecting the City; and, the receiving of advice that is subject to solicitor-client privilege, including communications necessary for that purpose.

14.2 Disposition Strategy – Portion of the Wentworth Lodge Lands (PED19138) (Ward 13) (Deferred by Committee at its meeting of July 8, 2019)

Pursuant to Section 8.1, Sub-sections (c) and (k) of the City's Procedural By-law 18-270, and Section 239(2), Sub-sections (c) and (k) of the *Ontario Municipal Act*, 2001, as amended, as the subject matter pertains to a proposed or pending acquisition or disposition of land; and, a position, plan, procedure, criteria or instruction to be applied to any negotiations carried on or to be carried on by or on behalf of the municipality or local board.

14.3 Waterfront Lease Update (LS18053(d)) (Ward 2)

Pursuant to Section 8.1, Sub-sections (e) and (f) of the City's Procedural By-law 18-270; and, Section 239(2), Sub-sections (e), and (f) of the *Ontario Municipal Act*, 2001, as amended, as the subject matter pertains to litigation or potential litigation, including matters before administrative tribunals, affecting the City; and, the receiving of advice that is subject to solicitor-client privilege, including communications necessary for that purpose.

14.4 Ombudsman's Preliminary Report respecting the Investigation into Meetings of the City Manager Recruitment Steering Committee

Pursuant to Section 239(3)(b) of the *Ontario Municipal Act*, 2001, as amended, as the subject matter pertains to an ongoing investigation respecting the municipality, a local board or a municipally-controlled corporation by the Ombudsman, appointed under the *Ombudsman Act*.

14.5 Roadway Sign Support Structures (PW19073) (City Wide)

Pursuant to Section 8.1, Sub-sections (e) and (f) of the City's Procedural By-law 18-270; and, Section 239(2), Sub-sections (e), and (f) of the *Ontario Municipal Act*, 2001, as amended, as the subject matter pertains to litigation or potential litigation, including matters before administrative tribunals, affecting the City; and, the receiving of advice that is subject to solicitor-client privilege, including communications necessary for that purpose.

Reports that are attached are public information and were provided as background reference only.

*14.6 Potential Litigation – Building Permit Issues (LS190035/PED19179) (Ward 13)

Pursuant to Section 8.1, Sub-sections (e) and (f) of the City's Procedural By-law 18-270, and Section 239(2), Sub-sections (e) and (f) of the *Ontario Municipal Act*, 2001, as amended, as the subject matter pertains to litigation or potential litigation, including matters before administrative tribunals, affecting the City; and, the receiving of advice that is subject to solicitor-client privilege, including communications necessary for that purpose.

*14.7 Update re: Local Planning Appeal Tribunal appeals of Pier 6, 7 and 8 (LS19033/PED19180) (City Wide)

Pursuant to Section 8.1, Sub-sections (e) and (f) of the City's Procedural By-law 18-270, and Section 239(2), Sub-sections (e) and (f) of the *Ontario Municipal Act*, 2001, as amended, as the subject matter pertains to litigation or potential litigation, including matters before administrative tribunals, affecting the City; and, the receiving of advice that is subject to solicitor-client privilege, including communications necessary for that purpose.

*14.8 Personnel Matters

Pursuant to Section 8.1, Sub-sections (b) and (d) of the City's Procedural By-law 18-270, and Section 239(2), Sub-sections (b) and (d) of the *Ontario Municipal Act*, 2001, as amended, as the subject matter pertains to personal matters about an identifiable individual, including City employees; and, labour relations or employee negotiations.

15. ADJOURNMENT



GENERAL ISSUES COMMITTEE MINUTES 19-013

9:30 a.m.

Monday, July 8, 2019

Council Chambers

Hamilton City Hall

71 Main Street West

Present: Mayor F. Eisenberger, Deputy Mayor L. Ferguson (Chair)
Councillors M. Wilson, J. Farr, N. Nann, C. Collins, T. Jackson,
E. Pauls, J. P. Danko, B. Clark, M. Pearson, B. Johnson,
A. VanderBeek, J. Partridge

Absent: Councillors S. Merulla, T. Whitehead – Personal

THE FOLLOWING ITEMS WERE REFERRED TO COUNCIL FOR CONSIDERATION:

1. Local Impact of the Celebrate Ontario Fund on Festivals in Hamilton (PED19147) (City Wide) (Item 7.1)

(Farr/Nann)

That Report PED19147, respecting the Local Impact of the Celebrate Ontario Fund on Festivals in Hamilton, be referred to the August 2019 Emergency & Community Services Committee meeting.

Result: Motion CARRIED by a vote of 13 to 0, as follows:

YES - Councillor Maureen Wilson
YES - Councillor Jason Farr
YES - Councillor Ninder Nann
NOT PRESENT - Councillor Sam Merulla
NOT PRESENT - Councillor Chad Collins
YES - Councillor Tom Jackson
YES - Councillor Esther Pauls
YES - Councillor John-Paul Danko
YES - Deputy-Mayor Lloyd Ferguson
YES - Mayor Fred Eisenberger
YES - Councillor Judi Partridge
NOT PRESENT - Councillor Terry Whitehead
YES - Councillor Arlene VanderBeek

2. Recognition for Local Order of Canada Recipients (Item 8.1)

(Eisenberger/VanderBeek)

That the presentation provided by Justin Page, CM, respecting recognition for local Order of Canada Recipients, be received and referred to staff for appropriate action.

Result: Motion CARRIED by a vote of 12 to 0, as follows:

YES - Councillor Maureen Wilson
 YES - Councillor Jason Farr
 YES - Councillor Nrinder Nann
 NOT PRESENT - Councillor Sam Merulla
 NOT PRESENT - Councillor Chad Collins
 YES - Councillor Tom Jackson
 YES - Councillor Esther Pauls
 NOT PRESENT - Councillor John-Paul Danko
 YES - Deputy-Mayor Lloyd Ferguson
 YES - Mayor Fred Eisenberger
 YES - Councillor Judi Partridge
 NOT PRESENT - Councillor Terry Whitehead
 YES - Councillor Arlene VanderBeek
 YES - Councillor Brenda Johnson
 YES - Councillor Maria Pearson
 YES - Councillor Brad Clark

3. Hamilton Urban Indigenous Strategy (HSC19030) (City Wide) (Item 9.1)

(Clark/Eisenberger)

That the direction of the Hamilton Urban Indigenous Strategy, be endorsed, in principle.

Result: Motion CARRIED by a vote of 12 to 0, as follows:

YES - Councillor Maureen Wilson
 YES - Councillor Jason Farr
 YES - Councillor Nrinder Nann
 NOT PRESENT - Councillor Sam Merulla
 YES - Councillor Chad Collins
 NOT PRESENT - Councillor Tom Jackson
 YES - Councillor Esther Pauls
 YES - Councillor John-Paul Danko
 YES - Deputy-Mayor Lloyd Ferguson
 YES - Mayor Fred Eisenberger
 YES - Councillor Judi Partridge
 NOT PRESENT - Councillor Terry Whitehead

YES - Councillor Arlene VanderBeek
NOT PRESENT - Councillor Brenda Johnson
YES - Councillor Maria Pearson
YES - Councillor Brad Clark

4. **2020 Budget Guidelines, Outlook and Process (FCS19054) (City Wide) (Item 9.2)**

(Eisenberger/Pearson)

- (a) That staff be directed to report back on a list of user fees that can be increased towards full cost recovery, or user fee waivers (including marginal cost facility leases) that can be reduced or eliminated over a one to three-year phase in period;
- (b) That for all other user fees, the fee be increased by a rate of 3.0% and that any user fee increases below the guideline be forwarded for consideration with appropriate explanation;
- (c) That staff be directed to report back to the General Issues Committee by October 2019 with an updated 2020 Tax Budget Outlook, ***with that report to provide actions, as it relates to all three (3) of the following scenarios:***
 - (i) Options that result in a 2.0% tax increase for City Departments, plus a 1.3% tax increase for Capital and a tax increase for Provincial Funding Shortfalls (currently estimated at 1.3%). This would result in a tax increase of about 4.6% and require \$18.3M in reductions from the current Outlook position;
 - (ii) Options that result in a 1.0% tax increase for City Departments plus a 1.3% tax increase for Capital and a tax increase for Provincial Funding Shortfalls (currently estimated at 1.3%). This would result in a tax increase of about 3.6% and require \$27.0M in reductions from the current Outlook position;
 - (iii) Options that result in a 0.0% tax increase for City Departments, plus a 1.3% tax increase for Capital and a tax increase for Provincial Funding Shortfalls (currently estimated at 1.3%). This would result in a tax increase of about 2.6% and require \$35.7M in reductions from the current Outlook position;
- (d) That Police, Library and Conservation Authorities target a 2020 tax operating budget guideline based on an increase of 2.0% and that any increase beyond the guideline be forwarded for consideration with explanation;

- (e) That all other Boards and Agencies including Hamilton Beach Rescue Unit, Royal Botanical Gardens, Farmers' Market and the Community Enrichment Fund target a 0% increase and that any increase beyond the guideline be forwarded for consideration with explanation;
- (f) That the 2020 Tax Capital budget be submitted with a 0.5% tax increase for capital financing of discretionary block funded projects; an additional 0.26% tax increase for capital financing of Public Transit Infrastructure Fund (PTIF) projects; an additional 0.23% for DC Exemptions; and, an additional 0.14% increase for capital financing of the Downtown Office Accommodation Strategy;
- (g) That staff report back, to the General Issues Committee, with options that include the use of reserves, reducing reliance on debt and reducing operating costs in order to reduce the current projection of a rate 4.5% increase when submitting the 2020 Rate Supported Budget;
- (h) *That the matter of a 0.13% increase for capital financing of West Harbour Development (WH) for a total of 1.3% tax increase, be referred to the West Harbour Development Sub-Committee for consideration; and,***
- (i) *That staff be directed to report back to the General Issues Committee, with an alternative funding strategy that would reflect the commitment to transit by senior levels of government.***

Result: Sub-section (b) CARRIED by a vote of 12 to 1, as follows:

YES - Councillor Maureen Wilson
 YES - Councillor Jason Farr
 YES - Councillor Nrinder Nann
 NOT PRESENT - Councillor Sam Merulla
 YES - Councillor Chad Collins
 YES - Councillor Tom Jackson
 YES - Councillor Esther Pauls
 YES - Councillor John-Paul Danko
 YES - Deputy-Mayor Lloyd Ferguson
 YES - Mayor Fred Eisenberger
 NO - Councillor Judi Partridge
 NOT PRESENT - Councillor Terry Whitehead
 NOT PRESENT - Councillor Arlene VanderBeek
 YES - Councillor Brenda Johnson
 YES - Councillor Maria Pearson
 YES - Councillor Brad Clark

Result: Sub-sections (a) and (c) through (i), AS AMENDED, CARRIED by a vote of 12 to 1, as follows:

YES - Councillor Maureen Wilson
 YES - Councillor Jason Farr
 YES - Councillor Nrinder Nann
 NOT PRESENT - Councillor Sam Merulla
 YES - Councillor Chad Collins
 YES - Councillor Tom Jackson
 YES - Councillor Esther Pauls
 YES - Councillor John-Paul Danko
 NO - Deputy-Mayor Lloyd Ferguson
 YES - Mayor Fred Eisenberger
 YES - Councillor Judi Partridge
 NOT PRESENT - Councillor Terry Whitehead
 NOT PRESENT - Councillor Arlene VanderBeek
 YES - Councillor Brenda Johnson
 YES - Councillor Maria Pearson
 YES - Councillor Brad Clark

5. Impact of Provincial Policy Changes (FCS19053) (City Wide) (Item 10.1)

(Johnson/Partridge)

That Report FCS19053, respecting the Impact of Provincial Policy Changes, be received.

CARRIED

6. Business Improvement Area Advisory Committee Report 19-006, June 11, 2019 (Item 10.2)

(Collins/Jackson)

That Item 2 of the Business Improvement Area Advisory Committee Report 19-006, which reads as follows, be referred to the Hamilton Police Services Board for discussion:

2. Increased Community Policing and Engagement Within the Business Improvement Areas (Item 9.2)

That the Hamilton Police Services Board be requested to investigate the feasibility of more community policing and engagement within the Business Improvement Area's across the City and respond back to the Business Improvement Area Advisory Committee.

Result: Motion CARRIED by a vote of 12 to 0, as follows:

YES - Councillor Maureen Wilson

YES - Councillor Jason Farr
 YES - Councillor Nrinder Nann
 NOT PRESENT - Councillor Sam Merulla
 YES - Councillor Chad Collins
 YES - Councillor Tom Jackson
 YES - Councillor Esther Pauls
 YES - Councillor John-Paul Danko
 YES - Deputy-Mayor Lloyd Ferguson
 NOT PRESENT - Mayor Fred Eisenberger
 YES - Councillor Judi Partridge
 NOT PRESENT - Councillor Terry Whitehead
 NOT PRESENT - Councillor Arlene VanderBeek
 YES - Councillor Brenda Johnson
 YES - Councillor Maria Pearson
 YES - Councillor Brad Clark

7. Airport Sub-Committee Report 19-003, June 21, 2019 (Item 10.3)

(Partridge/Pearson)

(a) Property Acquisition and Lease Negotiations for the John C. Munro Hamilton International Airport (PED19136) (City Wide) (Item 14.3)

That the contents of Report PED19136, respecting the Property Acquisition and Lease Negotiations for the John C. Munro Hamilton International Airport remain confidential.

(b) Sub-Lease Negotiations for the John C. Munro Hamilton International Airport (PED19137) (City Wide) (Item 14.4)

That the contents of Report PED19137, respecting Sub-Lease Negotiations for the John C. Munro Hamilton International Airport including recommendations, remain confidential.

(c) Consultant Support for Lease Negotiations Between the City of Hamilton and TradePort International Inc. for the John C. Munro Hamilton International Airport (PED19135) (City Wide) (Item 14.5)

That the contents of Report PED19135, respecting Consultant Support for Lease Negotiations between the City of Hamilton and TradePort International Inc. for the John C. Munro Hamilton International Airport including recommendations, remain confidential.

Result: Motion CARRIED by a vote of 10 to 1, as follows:

YES - Councillor Maureen Wilson
 YES - Councillor Jason Farr
 YES - Councillor Nrinder Nann
 NOT PRESENT - Councillor Sam Merulla
 YES - Councillor Chad Collins
 YES - Councillor Tom Jackson
 YES - Councillor Esther Pauls
 NO - Councillor John-Paul Danko
 YES - Deputy-Mayor Lloyd Ferguson
 NOT PRESENT - Mayor Fred Eisenberger
 YES - Councillor Judi Partridge
 NOT PRESENT - Councillor Terry Whitehead
 NOT PRESENT - Councillor Arlene VanderBeek
 YES - Councillor Brenda Johnson
 YES - Councillor Maria Pearson
 NOT PRESENT - Councillor Brad Clark

**8. Non-Union Compensation Sub-Committee Report 19-001, June 24, 2019
(Item 10.4)**

(Pearson/B. Johnson)

(a) Appointment of Chair and Vice Chair (Item A)

- (i) That Councillor L. Ferguson be appointed as Chair of the Non-Union Compensation Sub-Committee for the balance of the 2018-2022 term of Council; and,
- (ii) That Councillor M. Pearson be appointed as Vice Chair of the Non-Union Compensation Sub-Committee for the balance of the 2018-2022 term of Council.

(b) 2019 Non-Union Management & Professional Exempt Group Compensation (HUR19014) (City Wide) (Item 8.2)

That the contents of Report HUR19014, respecting the compensation of the Non-Union Management & Professional Exempt Group of employees, remain confidential until approved by Council.

Result: Motion CARRIED by a vote of 11 to 0, as follows:

YES - Councillor Maureen Wilson
 YES - Councillor Jason Farr
 YES - Councillor Nrinder Nann
 NOT PRESENT - Councillor Sam Merulla
 YES - Councillor Chad Collins

YES - Councillor Tom Jackson
 YES - Councillor Esther Pauls
 YES - Councillor John-Paul Danko
 YES - Deputy-Mayor Lloyd Ferguson
 NOT PRESENT - Mayor Fred Eisenberger
 YES - Councillor Judi Partridge
 NOT PRESENT - Councillor Terry Whitehead
 NOT PRESENT - Councillor Arlene VanderBeek
 YES - Councillor Brenda Johnson
 YES - Councillor Maria Pearson
 NOT PRESENT - Councillor Brad Clark

9. Affordable Housing Site Selection Sub-Committee Report 19-001, June 18, 2019 (Item 10.5)

(Johnson/Pearson)

(a) Appointment of Chair and Vice Chair (Item 1)

- (i) That Councillor C. Collins be appointed Chair of the Affordable Housing Site Selection Sub-Committee, for the 2018-2022 term; and,
- (ii) That Councillor N. Nann be appointed Vice-Chair of the Affordable Housing Site Selection Sub-Committee, for the 2018-2022 term.

(b) Properties and Process for Disposition of Lands for Affordable Housing (PED17219(a)) (City Wide)

That Report PED17219(a), respecting Properties and Process for Disposition of Lands for Affordable Housing, be received.

(c) Affordable Housing Initiative - 191 York Boulevard (PED19133) (Ward 2) (Item 14.1)

That the entirety of Report PED19133, respecting an Affordable Housing Initiative - 191 York Boulevard, remain confidential.

(d) Disposition and Transaction Strategies to Achieve Affordable Housing At 60 Caledon Avenue (PED19134) (Ward 8) (Item 14.2)

That the entirety of Report PED19134, respecting Disposition and Transaction Strategies to Achieve Affordable Housing At 60 Caledon Avenue, remain confidential.

Result: Motion CARRIED by a vote of 12 to 0, as follows:

YES - Councillor Maureen Wilson
 YES - Councillor Jason Farr
 YES - Councillor Nrinder Nann
 NOT PRESENT - Councillor Sam Merulla
 YES - Councillor Chad Collins
 YES - Councillor Tom Jackson
 YES - Councillor Esther Pauls
 YES - Councillor John-Paul Danko
 YES - Deputy-Mayor Lloyd Ferguson
 NOT PRESENT - Mayor Fred Eisenberger
 YES - Councillor Judi Partridge
 NOT PRESENT - Councillor Terry Whitehead
 NOT PRESENT - Councillor Arlene VanderBeek
 YES - Councillor Brenda Johnson
 YES - Councillor Maria Pearson
 YES - Councillor Brad Clark

**10. School Board Properties Sub-Committee Report 19-001 - June 24, 2019
(Item 10.6)**

(Pauls/Jackson)

(a) Appointment of Chair and Vice Chair (Item 1)

- (i) That Councillor C. Collins be appointed as Chair of the School Board Properties Sub-Committee, for the 2018-2022 term; and,
- (ii) That Councillor S. Merulla be appointed as Vice-Chair of the School Board Properties Sub-Committee, for the 2018-2022 term.

(b) Hamilton-Wentworth District School Board Property at 155 Macassa Avenue, Hamilton (PED19139) (Ward 7) (Item 10.1)

- (i) That staff be authorized and directed to advise the Hamilton Wentworth District School Board of the City's interest in the potential acquisition of the lands located at 155 Macassa Avenue, Hamilton, legally described as Part of Lot 7, Concession 5 Barton, Part 2 on Plan 62R19152, City of Hamilton forming all of PIN 17007-0170, as shown on Appendix "A" attached to Report PED19139;
- (ii) That staff be authorized and directed to complete due diligence work, including appraisal, designated substance survey, building condition assessment, and demolition cost estimate work in

preparation for the potential acquisition of the Hamilton Wentworth District School Board lands located at 155 Macassa Avenue, Hamilton;

- (iii) That all costs related to the due diligence and feasibility investigation, to an upset amount of \$50 K, for the potential acquisition of the Hamilton Wentworth District School Board lands located at 155 Macassa Avenue, Hamilton, be authorized and funded from Ward 7 Capital Infrastructure Reserve Account No. 108057; and,
- (iv) That staff be directed to report back on an acquisition and funding strategy for the Hamilton Wentworth District School Board lands located at 155 Macassa Avenue, Hamilton.

(d) Motion respecting the Potential Acquisition of 16 Broughton Avenue East (Broughton East Park) (Item 14.1)

That the motion respecting the Potential Acquisition of 16 Broughton Avenue East (Broughton East Park), remain confidential.

Result: Motion CARRIED by a vote of 11 to 0, as follows:

YES - Councillor Maureen Wilson
 YES - Councillor Jason Farr
 YES - Councillor Nrinder Nann
 NOT PRESENT - Councillor Sam Merulla
 YES - Councillor Chad Collins
 YES - Councillor Tom Jackson
 YES - Councillor Esther Pauls
 CONFLICT - Councillor John-Paul Danko
 YES - Deputy-Mayor Lloyd Ferguson
 NOT PRESENT - Mayor Fred Eisenberger
 YES - Councillor Judi Partridge
 NOT PRESENT - Councillor Terry Whitehead
 NOT PRESENT - Councillor Arlene VanderBeek
 YES - Councillor Brenda Johnson
 YES - Councillor Maria Pearson
 YES - Councillor Brad Clark

11. Facility Naming Sub-Committee Report 19-001, June 25, 2019 (Item 10.7)

(Pearson/Collins)

(a) Appointment of Chair and Vice Chair (Item 1)

- (i) That Councillor M. Pearson be appointed Chair of the Facility Naming Sub-Committee for the 2018-2022 term; and,
- (ii) That Councillor L. Ferguson be appointed Vice Chair of the Facility Naming Sub-Committee for the 2018-2022 term.

(b) Naming of Jimmy Howard Park (PW19052) (Ward 5) (Item 10.1)

That the request to rename Beach Boulevard Park #3, 80 Beach Boulevard, to Jimmy Howard Park be approved, as this request meets the guidelines set out in the City of Hamilton Municipal Property and Building Naming Policy.

(c) Municipal Property & Building Naming Application - Rick Burjaw Tennis Courts at the Ancaster Tennis Club (Item 10.3)

WHEREAS, Rick Burjaw was a member of the Ancaster Tennis Club for over 17 years and President for 8 years;

WHEREAS, Mr. Burjaw voluntarily devoted many years to making improvements at the Tennis Club through expansion and growth of the facility; and

WHEREAS, the tennis courts located at Village Green Park, 291 Lodor Street, Ancaster currently do not have an existing name;

THEREFORE, BE IT RESOLVED:

That the request to name the tennis courts at Village Green Park, located at 291 Lodor Street, Ancaster to "The Rick Burjaw Tennis Courts", be approved, as it meets the guidelines set out in the City of Hamilton Municipal Property and Building Naming Policy.

Result: Motion CARRIED by a vote of 12 to 0, as follows:

YES - Councillor Maureen Wilson
 YES - Councillor Jason Farr
 YES - Councillor Nrinder Nann
 NOT PRESENT - Councillor Sam Merulla
 YES - Councillor Chad Collins

YES - Councillor Tom Jackson
 YES - Councillor Esther Pauls
 YES - Councillor John-Paul Danko
 YES - Deputy-Mayor Lloyd Ferguson
 NOT PRESENT - Mayor Fred Eisenberger
 YES - Councillor Judi Partridge
 NOT PRESENT - Councillor Terry Whitehead
 NOT PRESENT - Councillor Arlene VanderBeek
 YES - Councillor Brenda Johnson
 YES - Councillor Maria Pearson
 YES - Councillor Brad Clark

12. Government Relations Sub-Committee Report 19-001, June 27, 2019 (Item 10.8)

(Clark/Pearson)

(a) Appointment of Chair and Vice Chair (Item 1)

- (i) That Councillor B. Clark be appointed Chair of the Government Relations Sub-Committee for the 2018-2022 term; and,
- (ii) That Councillor S. Merulla be appointed Vice Chair of the Government Relations Sub-Committee for the 2018-2022 term.

(b) City of Hamilton Priorities for the 2019 Federal Election (CM19004) (Item 7.1)

That Report CM19004 respecting City of Hamilton Priorities for the 2019 Federal Election, be received.

(c) Bill 108 *More Homes, More Choice Act, 2019* (PED19150) (City Wide) (Item 7.2)

That Report PED19150 respecting Bill 108 *More Homes, More Choice Act, 2019*, be received.

(d) Response to the Proposed Provincial Restructuring of Local Public Health Agencies (HSC19038) (City Wide) (Item 7.3)

That Report HSC19038 respecting a Response to the Proposed Provincial restructuring of Local Public Health Agencies, be received.

- (e) **Reaffirmation of the City of Hamilton's Concerns respecting Proposed Restructuring of Local Public Health Agencies (Item 7.3)**
- (i) That staff be directed to draft correspondence to the Minister of Health to reaffirm the City of Hamilton's concerns with Public Health Service restructuring, and that the correspondence include the following:
- (1) Requesting that the Province focus on Public Health Units that require improvements;
 - (2) Information respecting preventative health measures to eliminate "hallway medicine";
 - (3) Information that underscores the broad mandate of Public Health;
- (ii) That letters of support respecting the Reaffirmation of the City of Hamilton's Concerns respecting Proposed Restructuring of Local Public Health Agencies be written by the following Official Advisors to the Government Relations Sub-Committee:
- (1) McMaster University
 - (2) Hamilton Chamber of Commerce
 - (3) Flamborough Chamber of Commerce
 - (4) Hamilton Health Services

- (f) **Bill 108 *More Homes, More Choice Act, 2019* respecting Development Charges Act Amendments (FCS19061) (City Wide) (Added Item 7.4)**

That Report FCS19061 respecting Bill 108 *More Homes, More Choice Act, 2019* Regarding Development Charges Act Amendments, be received.

Result: Motion CARRIED by a vote of 12 to 0, as follows:

YES - Councillor Maureen Wilson
YES - Councillor Jason Farr
YES - Councillor Nrinder Nann
NOT PRESENT - Councillor Sam Merulla
YES - Councillor Chad Collins
YES - Councillor Tom Jackson

YES - Councillor Esther Pauls
 YES - Councillor John-Paul Danko
 YES - Deputy-Mayor Lloyd Ferguson
 NOT PRESENT - Mayor Fred Eisenberger
 YES - Councillor Judi Partridge
 NOT PRESENT - Councillor Terry Whitehead
 NOT PRESENT - Councillor Arlene VanderBeek
 YES - Councillor Brenda Johnson
 YES - Councillor Maria Pearson
 YES - Councillor Brad Clark

13. Hamilton Future Fund Board of Governors Report 19-002 - June 25, 2019 (Item 10.9)

(Partridge/Eisenberger)

Deliberations on the Grant Applications received for the November 1, 2018 - January 14, 2019 Opening of the Hamilton Future Fund (Item 10.1)

- (a) That the grant application from the Hamilton Malayalee Samajam (Item 10.1.d) for the conversion of a sports field into a cricket field at 1095 Woodburn Road in the amount of \$358,000 be approved;
- (b) That the grant application from the 91st Highlanders Athletic Association (Item 10.1.a) for the installation of spectator bleachers and an outdoor gazebo structure at the Ray Lewis Track & Field Centre (Mohawk Sports Park) in the amount of \$150,000 be approved;
- (c) That the grant application from the Ancaster Tennis Club (Item 10.1.b) for the construction of a Tennis Dome in the amount of \$206,000 be approved;
- (d) That the grant application from the Beach Canal Lighthouse Group (Item 10.1.c) for the Restoration of the Hamilton Beach Strip Canal lighthouse and Keepers house in the amount of \$400,000 be approved conditional on the transfer of ownership from the federal government to the Hamilton Port Authority; and,
- (e) That the grant application from Compass Community Health (formerly North Hamilton Community Health Centre) (Item 10.1.e) be denied.

Result: Sub-section (c) CARRIED by a vote of 12 to 1, as follows:

NO - Councillor Maureen Wilson
 YES - Councillor Jason Farr
 YES - Councillor Nrinder Nann
 NOT PRESENT - Councillor Sam Merulla

YES - Councillor Chad Collins
 YES - Councillor Tom Jackson
 YES - Councillor Esther Pauls
 YES - Councillor John-Paul Danko
 YES - Deputy-Mayor Lloyd Ferguson
 YES - Mayor Fred Eisenberger
 YES - Councillor Judi Partridge
 NOT PRESENT - Councillor Terry Whitehead
 NOT PRESENT - Councillor Arlene VanderBeek
 YES - Councillor Brenda Johnson
 YES - Councillor Maria Pearson
 YES - Councillor Brad Clark

Result: Sub-sections (a), (b), (d) and (e) CARRIED by a vote of 13 to 0, as follows:

YES - Councillor Maureen Wilson
 YES - Councillor Jason Farr
 YES - Councillor Nrinder Nann
 NOT PRESENT - Councillor Sam Merulla
 YES - Councillor Chad Collins
 YES - Councillor Tom Jackson
 YES - Councillor Esther Pauls
 YES - Councillor John-Paul Danko
 YES - Deputy-Mayor Lloyd Ferguson
 YES - Mayor Fred Eisenberger
 YES - Councillor Judi Partridge
 NOT PRESENT - Councillor Terry Whitehead
 NOT PRESENT - Councillor Arlene VanderBeek
 YES - Councillor Brenda Johnson
 YES - Councillor Maria Pearson
 YES - Councillor Brad Clark

14. Hate Related Activities on City of Hamilton Properties (LS19031/PW19068) (City Wide) (Item 10.10)

(Eisenberger/Farr)

- (a) That, subsequent to internal and external review, Human Resources staff be directed to report back to General Issues Committee with the Hate Incident Prevention Policy and Procedure attached in draft form as Appendix "A" and "B" to Report LS19031/PW19068 respecting Hate Related Activities on City of Hamilton Properties respectively by October 2019;

- (b) That Legal Services staff be directed to prepare a by-law to address the issuance of trespass notices by City Staff for consideration by Council in October 2019;
- (c) That staff be directed to require facilities rental applicants and organizers of assemblies or demonstrations to abide by the Hate Related Incident Prevention Policy;
- (d) That the draft procedure for Notification of Assembly or Demonstration on City of Hamilton Public Spaces attached as Appendix "D" to Report LS19031/PW19068 respecting Hate Related Activities on City of Hamilton Properties, be approved in principle;
- (e) That the recommendations in Corporate Security Office Report CSOR 19-001, attached as Appendix "C" to Report LS19031/PW19068, respecting Hate Related Activities on City of Hamilton Properties, be approved as follows:
 - (i) That Corporate Security Office in coordination with Facility Management, Human Resources and Corporate Communications, produce and post signage to notify all persons entering the City Hall property of the expectations related to behaviour and conduct while on City property, and the City's Zero Tolerance approach regarding harassment, discrimination, hate, violence and criminal behaviour, including the collection of evidence to support law enforcement investigations;
 - (ii) That Corporate Security Office create a procedure for all security staff on how to collect, document, analyze and report on surveillance, materials and messaging during public gatherings and distribute their findings and evidence when required to various City divisions (i.e. Human Resources, Legal Services) and external Law Enforcement partners for further follow-up and investigation related to potential harassment, discrimination, hate, violence and criminal behaviour taking place in the open public spaces on the City Hall property;
 - (iii) That Corporate Security Office to procure safety mitigating tools such as portable barriers to support Hamilton Police in the enforcement of safe and peaceful demonstrations that take place in the City Hall outdoor public space;
 - (iv) That Corporate Security Office to procure the enhancement of the City Hall property video surveillance technology to increase its current general surveillance capacity to an evidentiary purpose solution.

- (v) That Corporate Security Office to research, identify and report on physical environment enhancements to the City Hall exterior open space to promote the safety and security of all persons who are attending the property for peaceful use and enjoyment of the space;
- (vi) That Corporate Security Office hire and train a Security Investigator for the purpose of providing security related services at City owned properties as required including but not limited to Assemblies and Protests. Corporate Security Office to further identify and report on future security staffing resource enhancements for City Hall to ensure appropriate resource levels are responsive to the needs of Members of Council and its Committee's, City staff, contractors, residents and visitors in the delivery of good government;
- (f) That a capital expenditure not exceeding \$100,000 from the Facilities Security Program Capital Account #3541941631 to implement the recommendations in sub-section (e) above be approved;
- (g) That staff be directed to hire a Security Investigator for a temporary 24 month period using the Budget Complement Control Policy, to be trained and tasked with investigating and documenting Hate Related Activities on City owned properties across the city and that funding for this position be allocated from Operating Budget Dept ID #790017, and that an operating budget enhancement be referred to the 2020 Operating Budget process;
- (h) That the item respecting Means to Mitigate the Use of City Parks and Public Spaces by "Hate Groups" be removed from the General Issues Committee Outstanding Business List; and,
- (i) ***That Legal staff be directed to contact Police or the Crown Attorney to determine if the City could issue prohibition to attend at municipal properties; specifically, the Hamilton City Hall Forecourt, as part of their condition of release via standard bail conditions or parole conditions, if convicted.***

Result: MAIN MOTION, AS AMENDED, CARRIED by a vote of 12 to 0, as follows:

YES - Councillor Maureen Wilson
 YES - Councillor Jason Farr
 YES - Councillor Nrinder Nann
 NOT PRESENT - Councillor Sam Merulla
 YES - Councillor Chad Collins
 YES - Councillor Tom Jackson
 YES - Councillor Esther Pauls
 YES - Councillor John-Paul Danko

YES - Deputy-Mayor Lloyd Ferguson
 YES - Mayor Fred Eisenberger
 YES - Councillor Judi Partridge
 NOT PRESENT - Councillor Terry Whitehead
 NOT PRESENT - Councillor Arlene VanderBeek
 YES - Councillor Brenda Johnson
 NOT PRESENT - Councillor Maria Pearson
 YES - Councillor Brad Clark

15. Integrating an Equity, Diversity & Inclusion (EDI) Framework to the Policies and Procedures of the Selection Committee and Interview Sub-Committees respecting Appointment of Citizens to the City's Agencies, Boards and Committees (Item 11.3)

(Nann/Johnson)

WHEREAS, the City's Strategic Plan states that diversity and inclusion are to be embraced and celebrated;

WHEREAS, the City's Strategic Plan also states "Hamilton has an open, transparent and accessible approach to City government that engages with and empowers all citizens to be involve in their community";

WHEREAS, Council approved establishing an EDI framework and directed staff to prepare a report on the steps that would be required to implement an equity, diversity and inclusion lens framework to City policy and program development, practices, service delivery, budgeting, business planning and prioritization, and report back to General Issues Committee no later than Q3 2019;

WHEREAS, the current City of Hamilton Policy respecting the Appointment of Citizens to the City's Agencies, Boards, Commissions, Advisory (Volunteer) Committees and Sub-Committees approved by Council on September 12, 2018 does not systematically integrate current and best practices of Equity, Diversity & Inclusion (EDI) in the recruitment, application, selection and interview processes; and,

WHEREAS, many other Canadian municipalities are also reviewing and improving their selection practices to achieve EDI outcomes;

THEREFORE, BE IT RESOLVED:

- (a) That, as part of the Equity, Diversity and Inclusion (EDI) framework, staff include recommendations for integrating an EDI framework to the City of Hamilton Policy respecting the Appointment of Citizens to the City's Agencies, Boards, Commissions, Advisory (Volunteer) Committees and Sub-Committees, including:

- (i) training and orientation of Selection Committee members and supporting staff to implement the revised recruitment, application, selection and interview processes; and,
- (b) That the final Equity, Diversity and Inclusion policy and procedures for Selection Committee be implemented starting with the 2022-2026 term of Council.

Result: Motion CARRIED by a vote of 12 to 0, as follows:

YES - Councillor Maureen Wilson
 YES - Councillor Jason Farr
 YES - Councillor Nrinder Nann
 NOT PRESENT - Councillor Sam Merulla
 YES - Councillor Chad Collins
 YES - Councillor Tom Jackson
 YES - Councillor Esther Pauls
 YES - Councillor John-Paul Danko
 YES - Deputy-Mayor Lloyd Ferguson
 YES - Mayor Fred Eisenberger
 YES - Councillor Judi Partridge
 NOT PRESENT - Councillor Terry Whitehead
 NOT PRESENT - Councillor Arlene VanderBeek
 YES - Councillor Brenda Johnson
 NOT PRESENT - Councillor Maria Pearson
 YES - Councillor Brad Clark

- 16. Amendment to Item 8 of the General Issues Committee Report 18-014, respecting Report PED16253(b) – 18-28 King Street East, Extension of Conditional Approval, Hamilton Heritage Property Grant Program and GORE Building Improvement Grant Program (Item 11.4)**

(Farr/Collins)

WHEREAS, at its meeting of December 11, 2013, Council approved Item 14 of the General Issues Committee Report 13-026, respecting Report PED13208 - 18-28 King Street East – Hamilton Heritage Property Grant Program and GORE Building Improvement Grant Program;

WHEREAS, at its meeting of December 9, 2015, Council approved an amendment to Item 14 of the General Issues Committee Report 13-026, respecting Report PED13208 - 18-28 King Street East – Hamilton Heritage Property Grant Program and GORE Building Improvement Grant Program, to extend the submission deadline for completion of the program applications to December 31, 2016;

WHEREAS, at its meeting of January 25, 2017, Council approved Item 4 of the Planning Committee Report 17-001, respecting the Hamilton Municipal Heritage Committee Report 16-010, December 15, 2016 regarding Report PED16193(a) Heritage Permit Application HP2016-028, under Part IV of the *Ontario Heritage Act*, for the Demolition of the Buildings at 24 and 28 King Street East, Hamilton;

WHEREAS, Hughson Business Space Corporation has advised that they plan to restore all five properties, and conditional site plan approval was issued on November 27, 2017, with an addendum containing further conditions being added on August 2, 2018;

WHEREAS, at its meeting of December 6, 2016, Council approved Item 30 of the General Issues Committee Report 17-025, respecting Report PED13208(a) - 18-28 King Street East – Hamilton Heritage Property Grant Program and GORE Building Improvement Grant Program, which extended the submission deadline for completion of the program applications to June 1, 2018;

WHEREAS, a Heritage Permit for the retention and restoration of the front portion of 24 and 28 King Street East and a fifth storey addition was approved on September 7, 2018;

WHEREAS, at its meeting of June 27, 2018, Council approved Item 8 of the General Issues Committee Report 18-014, which extended the submission deadline for Building Permit Applications to January 31, 2019; and

WHEREAS, at its meeting of February 13, 2019, Council approved Item 7.5 an Amendment to Item 8 of the General Issues Committee Report 18-014, which again extended the submission deadline for Building Permit Applications to July 31, 2019 as well as extending the submission deadline for the Hamilton Heritage Property Grant Program and GORE Building Improvement Grant Program for the completion of the program applications to January 31, 2020;

THEREFORE, BE IT RESOLVED:

- (a) That subsections (a) and (b) to Item 8 of the General Issues Committee Report 18-014, respecting Report PED16253(b) – 18-28 King Street East, Extension of Conditional Approval, Hamilton Heritage Property Grant Program and GORE Building Improvement Grant Program, be amended by deleting the words “January 31, 2020, and replacing them with the words “**July 31, 2020**”; and, by deleting the second reference to the word “July 31, 2019” and replacing it with the word “**January 31, 2020**”; to read as follows:

- 8. 18-28 King Street East, Extension of Conditional Approval, Hamilton Heritage Property Grant Program and GORE Building Improvement Grant Program (PED16253(b)) (Ward 2) (Item 8.1)**

- (a) That the deadline for the submission of a separate, completed Hamilton Heritage Property Grant Program (HHPGP) Application for each 18, 20, 22, 24 and 28 King Street East, for the previously approved conditional grant commitment to an upset limit of \$850,000 for the Hughson Business Space Corporation (Linda Barnett, David Blanchard, Ronald Quinn and William Rogan) the registered owners, be extended to no later than ~~January 31, 2020~~ **July 31, 2020**, conditional upon the receipt of a Building Permit Application being submitted to the City for the redevelopment of 18-28 King Street East no later than ~~July 31, 2019~~ **January 31, 2020**;
- (b) That the deadline for the submission of a separate, completed GORE Building Improvement Grant Program (GBIGP) Application for each 18, 20, 22, 24 and 28 King Street East, for the previously approved conditional grant commitment to an upset limit of \$250,000 under the GORE Building Improvement Grant Program (GBIGP) for Hughson Business Space Corporation (Linda Barnett, David Blanchard, Ronald Quinn and William Rogan), the registered owners, be extended to no later than ~~January 31, 2020~~ **July 31, 2020** conditional upon the receipt of a Building Permit Application being submitted to the City for the redevelopment of 18-28 King Street East no later than ~~July 31, 2019~~ **January 31, 2020**; and,
- (b) That subsection (c) to Item 8 of the General Issues Committee Report 18-014, respecting Report PED 16253 (b) – 18-28 King Street East, Extension of Conditional Approval, Hamilton Heritage Property Grant Program and GORE Building Improvement Grant Program, be amended by deleting the word “July 31, 2019” and replacing it with the word **“January 31, 2020”**, to read as follows:
- (a) That, should the Hughson Business Space Corporation (Linda Barnett, David Blanchard, Ronald Quinn and William Rogan) the registered owners of 18, 20, 22, 24 and 28 King Street East not submit a Building Permit Application for the redevelopment of 18-28 King Street East by ~~July 31, 2019~~ **January 31, 2020**, staff be directed to report back to the General Issues Committee for direction as to whether or not the conditional grant commitments, under the Hamilton Heritage Property Grant Program (HHPGP) and GORE Building Improvement Grant Program (GBIGP), for those properties should continue to be valid.

Result: Motion CARRIED by a vote of 12 to 0, as follows:

YES - Councillor Maureen Wilson

YES - Councillor Jason Farr
 YES - Councillor Nrinder Nann
 NOT PRESENT - Councillor Sam Merulla
 YES - Councillor Chad Collins
 YES - Councillor Tom Jackson
 YES - Councillor Esther Pauls
 YES - Councillor John-Paul Danko
 YES - Deputy-Mayor Lloyd Ferguson
 YES - Mayor Fred Eisenberger
 YES - Councillor Judi Partridge
 NOT PRESENT - Councillor Terry Whitehead
 NOT PRESENT - Councillor Arlene VanderBeek
 YES - Councillor Brenda Johnson
 NOT PRESENT - Councillor Maria Pearson
 YES - Councillor Brad Clark

**17. Application for Approval to Expropriate Property in Ward 3
(PED19142/LS19028/PW19061) (Ward 3) (Item 14.2)**

(Nann/Pauls)

That Report PED19142/LS19028/PW19061, respecting an Application for Approval to Expropriate Property in Ward 3, remain confidential save and except for any portions that need to be disclosed for the purposes of completing this expropriation at the discretion of the City Solicitor.

Result: Motion CARRIED by a vote of 11 to 0, as follows:

YES - Councillor Maureen Wilson
 YES - Councillor Jason Farr
 YES - Councillor Nrinder Nann
 NOT PRESENT - Councillor Sam Merulla
 YES - Councillor Chad Collins
 YES - Councillor Tom Jackson
 YES - Councillor Esther Pauls
 YES - Councillor John-Paul Danko
 YES - Deputy-Mayor Lloyd Ferguson
 YES - Mayor Fred Eisenberger
 YES - Councillor Judi Partridge
 NOT PRESENT - Councillor Terry Whitehead
 NOT PRESENT - Councillor Arlene VanderBeek
 YES - Councillor Brenda Johnson
 NOT PRESENT - Councillor Maria Pearson
 CONFLICT - Councillor Brad Clark

18. Application for Approval to Expropriate Property in Ward 15 (LS19026/PW19067/PED19141) (Ward 15) (Item 14.3)

(Partridge/Johnson)

That Report LS19026/PW19067/PED19141, respecting an Application for Approval to Expropriate Property in Ward 15, remain confidential save and except for any portions that need to be disclosed for the purposes of completing this expropriation at the discretion of the City Solicitor.

Result: Motion CARRIED by a vote of 11 to 0, as follows:

YES - Councillor Maureen Wilson
 YES - Councillor Jason Farr
 YES - Councillor Nrinder Nann
 NOT PRESENT - Councillor Sam Merulla
 YES - Councillor Chad Collins
 YES - Councillor Tom Jackson
 YES - Councillor Esther Pauls
 YES - Councillor John-Paul Danko
 NOT PRESENT - Deputy-Mayor Lloyd Ferguson
 YES - Mayor Fred Eisenberger
 YES - Councillor Judi Partridge
 NOT PRESENT - Councillor Terry Whitehead
 NOT PRESENT - Councillor Arlene VanderBeek
 YES - Councillor Brenda Johnson
 NOT PRESENT - Councillor Maria Pearson
 YES - Councillor Brad Clark

19. Waterfront Lease Update (LS18053(c)) (Ward 2) (Item 14.4)

(Collins/Partridge)

That Report LS18053, respecting the Waterfront Lease Update, Appendix and the balance of the recommendations remain confidential.

Result: Motion CARRIED by a vote of 11 to 0, as follows:

YES - Councillor Maureen Wilson
 YES - Councillor Jason Farr
 YES - Councillor Nrinder Nann
 NOT PRESENT - Councillor Sam Merulla
 YES - Councillor Chad Collins
 YES - Councillor Tom Jackson
 YES - Councillor Esther Pauls
 YES - Councillor John-Paul Danko
 NOT PRESENT - Deputy-Mayor Lloyd Ferguson
 YES - Mayor Fred Eisenberger

YES - Councillor Judi Partridge
NOT PRESENT - Councillor Terry Whitehead
NOT PRESENT - Councillor Arlene VanderBeek
YES - Councillor Brenda Johnson
NOT PRESENT - Councillor Maria Pearson
YES - Councillor Brad Clark

FOR INFORMATION:**(a) APPROVAL OF AGENDA (Item 2)**

The Committee Clerk advised of the following changes to the agenda:

1. COMMUNICATIONS (Item 5)

- 5.6 Correspondence from the Hamilton Status of Women Committee in support of Item 11.3, respecting Integrating an Equity, Diversity & Inclusion (EDI) Framework to the Policies and Procedures of the Selection Committee and Interview Sub- Committees respecting the Appointment of Citizens to the City's Agencies, Boards and Committees

Recommendation: Be received and referred to the consideration of Item 11.3.

- 5.7 Correspondence from Lauren Stephen respecting an Individual Arrested in the Pride Hamilton Disturbance

Recommendation: Be received.

- 5.8 Correspondence from C.A. Klassen respecting an Open Letter to Mayor Eisenberger and Pride Events

Recommendation: Be received.

- 5.9 Hamilton Airport International ASC Update (Climate Change)

Recommendation: Be received.

6. DELEGATION REQUESTS (Item 6)

- 6.1 Kristeen Sprague, respecting Item 10.1 Hate Related Activities on City of Hamilton Properties (LS19031/PW19068) (For July 8, 2019)
– THIS REQUEST WAS WITHDRAWN FROM THE AGENDA
- 6.2 David Carson, respecting Airport Carbon Accreditation (For July 8, 2019)
- 6.3 Chris McLaughlin, Bay Area Restoration Council, respecting Item 11.2, the City-Wide Stormwater Rate Program Review (For July 8, 2019)
- 6.4 Jen Baker, Hamilton Naturalists' Club, respecting Item 11.2, the City-Wide Stormwater Rate Program Review (For July 8, 2019)
- 6.5 Justin Long, Yellow Vests Protestors, respecting Hate Related Activities on City of Hamilton Properties (For July 8, 2019)
- 6.6 Ian Borsuk, Environment Hamilton, respecting Item 11.2, City-Wide Stormwater Rate Program Review (For July 8, 2019)
- 6.7 Mike Wood and Elizabeth Ellis, Hamilton ACORN, respecting Item 11.1, Modifications to the Guidelines and Criteria for the Barton/Kenilworth Tax Increment Grant Program (For July 8, 2019)
- 6.8 Giuliana Casimirri, Green Venture, respecting Item 11.2, City-Wide Stormwater Rate (For July 8, 2019)

(Partridge/Eisenberger)

That the agenda for the July 8, 2019 General Issues Committee meeting, be approved, as amended.

Result: Motion CARRIED by a vote of 13 to 0, as follows:

YES - Councillor Maureen Wilson
YES - Councillor Jason Farr
YES - Councillor Nrinder Nann
NOT PRESENT - Councillor Sam Merulla
NOT PRESENT - Councillor Chad Collins
YES - Councillor Tom Jackson
YES - Councillor Esther Pauls
YES - Councillor John-Paul Danko
YES - Deputy-Mayor Lloyd Ferguson
YES - Mayor Fred Eisenberger
YES - Councillor Judi Partridge

NOT PRESENT - Councillor Terry Whitehead
 YES - Councillor Arlene VanderBeek
 YES - Councillor Brenda Johnson
 YES - Councillor Maria Pearson
 YES - Councillor Brad Clark

(b) DECLARATIONS OF INTEREST (Item 2)

Councillor J. P. Danko declared an interest to Item 10.6 – School Board Properties Sub-Committee Report 19-001, as his wife is the Vice Chair of the Hamilton-Wentworth District School Board.

Councillor M. Pearson declared an interest to Items 6.7, 8.7 and 11.1, being the delegation request/delegation by Mike Wood and Elizabeth Ellis, Hamilton ACORN, respecting Item 11.1, Modifications to the Guidelines and Criteria for the Barton/Kenilworth Tax Increment Grant Program; and, the Motion respecting the same matter, as she is a rental property landlord.

Councillor A. VanderBeek declared an interest to Items 6.7, 8.7 and 11.1, being the delegation request/delegation by Mike Wood and Elizabeth Ellis, Hamilton ACORN, respecting Item 11.1, Modifications to the Guidelines and Criteria for the Barton/Kenilworth Tax Increment Grant Program; and, the Motion respecting the same matter, as she is a rental property landlord.

Councillor B. Clark declared an interest to Item 14.2, respecting Report PED19142/LS19028/PW19061) - Application for Approval to Expropriate Property in Ward 3.

(c) APPROVAL OF MINUTES OF THE PREVIOUS MEETINGS (Item 4)

(i) June 19, 2019 (Item 4.1)

(Johnson/Pearson)

That the Minutes of the June 19, 2019 meeting of the General Issues Committee be approved, as presented.

Result: Motion CARRIED by a vote of 13 to 0, as follows:

YES - Councillor Maureen Wilson
 YES - Councillor Jason Farr
 YES - Councillor Nrinder Nann
 NOT PRESENT - Councillor Sam Merulla
 NOT PRESENT - Councillor Chad Collins
 YES - Councillor Tom Jackson
 YES - Councillor Esther Pauls

YES - Councillor John-Paul Danko
YES - Deputy-Mayor Lloyd Ferguson
YES - Mayor Fred Eisenberger
YES - Councillor Judi Partridge
NOT PRESENT - Councillor Terry Whitehead
YES - Councillor Arlene VanderBeek
YES - Councillor Brenda Johnson
YES - Councillor Maria Pearson
YES - Councillor Brad Clark

(d) COMMUNICATIONS (Item 5)

(Pearson/Nann)

That Communication Items 5.1 to 5.9, be approved, as follows:

- 5.1 Correspondence from Donna Hays, respecting an alternative observation of the Yellow Vests movement.

Recommendation: Be received and referred to the consideration of Item 10.10.

- 5.2 Correspondence from Myke Hutchings respecting the 2SLGBTQIA+ community in Hamilton.

Recommendation: Be received and referred to the consideration of Item 10.10.

- 5.3 Correspondence from Associate Professors Margot Francis and Tamara El-Hoss, Brock University, respecting Pride Violence.

Recommendation: Be received and referred to the consideration of Item 10.10.

- 5.4 Correspondence from Erin Poole respecting Pride Violence

Recommendation: Be received and referred to the consideration of Item 10.10.

- 5.5 Correspondence from Melanie Parish, respecting Pride and Post Pride Happenings in Hamilton

Recommendation: Be received and referred to the consideration of Item 10.10.

- 5.6 Correspondence from the Hamilton Status of Women Committee in support of Item 11.3, respecting Integrating an Equity, Diversity & Inclusion (EDI) Framework to the Policies and Procedures of the Selection Committee and Interview Sub-Committees respecting the Appointment of Citizens to the City's Agencies, Boards and Committees

Recommendation: Be received and referred to the consideration of Item 11.3.

- 5.7 Correspondence from Lauren Stephen respecting an Individual Arrested in Pride Hamilton Disturbance

Recommendation: Be received.

- 5.8 Correspondence from C.A. Klassen respecting an Open Letter to Mayor Eisenberger and Pride Events

Recommendation: Be received.

- 5.9 Hamilton Airport International ASC Update (Climate Change)

Recommendation: Be received.

CARRIED

(e) DELEGATION REQUESTS (Item 6)

(Pearson/Nann)

That the following delegation requests be approved, as shown below:

- 6.2 David Carson, respecting Airport Carbon Accreditation (For the July 8, 2019)
- 6.3 Chris McLaughlin, Bay Area Restoration Council, respecting Item 11.2, City-Wide Stormwater Rate Program Review (For the July 8, 2019)

- 6.4 Jen Baker, Hamilton Naturalists' Club, respecting Item 11.2, City-Wide Stormwater Rate Program Review (For the July 8, 2019)
- 6.5 Justin Long, Yellow Vests Protestors, respecting Item 10.10 Hate Related Activities on City of Hamilton Properties (LS19031/PW19068) (City Wide) (For the July 8, 2019)
- 6.6 Ian Borsuk, Environment Hamilton, respecting Item 11.2, Stormwater Rate (For the July 8, 2019)
- 6.7 Mike Wood and Elizabeth Ellis, Hamilton ACORN, respecting Item 11.1, Modifications to the Guidelines and Criteria for the Barton/Kenilworth Tax Increment Grant Program (For the July 8, 2019)
- 6.8 Giuliana Casimirri, Green Venture, respecting Item 11.2, City-Wide Stormwater Rate (For the July 8, 2019)

Result: Motion CARRIED by a vote of 13 to 0, as follows:

YES - Councillor Maureen Wilson
 YES - Councillor Jason Farr
 YES - Councillor Nrinder Nann
 NOT PRESENT - Councillor Sam Merulla
 NOT PRESENT - Councillor Chad Collins
 YES - Councillor Tom Jackson
 YES - Councillor Esther Pauls
 YES - Councillor John-Paul Danko
 YES - Deputy-Mayor Lloyd Ferguson
 YES - Mayor Fred Eisenberger
 YES - Councillor Judi Partridge
 NOT PRESENT - Councillor Terry Whitehead
 YES - Councillor Arlene VanderBeek

(f) PUBLIC HEARINGS / DELEGATIONS (Item 8)

(i) Justin Page, CM, respecting Recognition for Local Order of Canada Recipients (Item 8.1)

Justin Page, CM, addressed Committee respecting recognition for local Order of Canada Recipients.

For disposition of this matter, please refer to Item 2.

(ii) David Carson, respecting Airport Carbon Accreditation (Item 8.2)

David Carson, addressed Committee respecting Airport Carbon Accreditation.

(Pearson/VanderBeek)

That the presentation provided by David Carson, respecting Airport Carbon Accreditation, be received.

CARRIED**(iii) Chris McLaughlin, Bay Area Restoration Council, respecting Item 11.2, City-Wide Stormwater Rate Program Review (Item 8.3)**

Chris McLaughlin, Bay Area Restoration Council, addressed Committee respecting Item 11.2, a City-Wide Stormwater Rate Program Review.

(Partridge/Pearson)

That the presentation provided by Chris McLaughlin, Bay Area Restoration Council, respecting Item 11.2, the City-Wide Stormwater Rate Program Review, be received.

CARRIED**(iv) Jen Baker, Hamilton Naturalists' Club, respecting Item 11.2, City-Wide Stormwater Rate Program Review (Item 8.4)**

Jen Baker, Hamilton Naturalists' Club, addressed Committee respecting Item 11.2, the City-Wide Stormwater Rate Program Review.

(Eisenberger/Pauls)

That the presentation provided by Jen Baker, Hamilton Naturalists' Club, respecting Item 11.2, the City-Wide Stormwater Rate Program Review, be received.

CARRIED**(v) Justin Long, Yellow Vests Protestors, respecting Hate Related Activities on City of Hamilton Properties (Item 8.5)**

Justin Long, Yellow Vests Protestors, addressed Committee respecting Hate Related Activities on City of Hamilton Properties.

(Pearson/Partridge)

That the presentation provided by Justin Long, Yellow Vests Protestors, respecting Hate Related Activities on City of Hamilton Properties, be received.

CARRIED

- (vi) **Ian Borsuk, Environment Hamilton, respecting Item 11.2, Stormwater Rate (Item 8.6)**

Ian Borsuk, Environment Hamilton, addressed Committee respecting Item 11.2, the City-Wide Stormwater Rate Program Review.

(Pauls/Danko)

That the presentation provided by Ian Borsuk, Environment Hamilton, respecting Item 11.2, Stormwater Rate, be received.

CARRIED

- (vii) **Mike Wood and Elizabeth Ellis, Hamilton ACORN, respecting Item 11.1, Modifications to the Guidelines and Criteria for the Barton/Kenilworth Tax Increment Grant Program (Item 8.7)**

Mike Wood and Elizabeth Ellis, Hamilton ACORN, addressed Committee respecting Item 11.1, Modifications to the Guidelines and Criteria for the Barton/Kenilworth Tax Increment Grant Program.

(Farr/Nann)

That the presentation provided by Mike Wood and Elizabeth Ellis, Hamilton ACORN, respecting Item 11.1, Modifications to the Guidelines and Criteria for the Barton/Kenilworth Tax Increment Grant Program, be received.

CARRIED

- (viii) **Giuliana Casimirri, Green Venture, respecting Item 11.2, a City-Wide Stormwater Rate Program Review (Item 8.8)**

Giuliana Casimirri, Green Venture, addressed Committee respecting Item 11.2, a City-Wide Stormwater Rate Program Review.

(Farr/Jackson)

That the presentation provided by Giuliana Casimirri, Green Venture, respecting Item 11.2, the City-Wide Stormwater Rate Program Review, be received.

CARRIED

- (g) **STAFF PRESENTATIONS (Item 9)**

- (i) **Hamilton Urban Indigenous Strategy (HSC19030) (City Wide) (Item 9.1)**

Paul Johnson, General Manager of the Healthy and Safe Communities Department, introduced Shelly Hill, Senior Project Manager Urban Indigenous Strategy; Nicole Jones, Coordinator, Indigenous Engagement and Initiatives; and, Krystal Summers, Program Manager for the Hamilton Executive Directors' Aboriginal Coalition (HEDAC), who provided an

overview of Report HCS19030, respecting the Hamilton Urban Indigenous Strategy.

(Eisenberger/Pearson)

That the presentation respecting Report HCS19030, respecting the Hamilton Urban Indigenous Strategy, be received.

CARRIED

A copy of the presentation is available on the City's website at www.hamilton.ca or through the Office of the City Clerk.

For disposition of this matter, please refer to Item 3.

(ii) 2020 Budget Guidelines, Outlook and Process (FCS19054) (City Wide) (Item 9.2)

Mike Zegarac, General Manager of Finance and Corporate Services, provided an overview of Report FCS19054, respecting the 2020 Budget Guidelines, Outlook and Process.

(Eisenberger/Partridge)

That the presentation respecting Report FCS19054, respecting the 2020 Budget Guidelines, Outlook and Process, be received.

CARRIED

A copy of the presentation is available on the City's website at www.hamilton.ca or through the Office of the City Clerk.

(Danko/Nann)

That sub-section (d) to Report FCS19054, respecting the 2020 Budget Guidelines, Outlook and Process, be amended by adding the words " ***emulates the three (3) scenarios being reviewed by the City, being a 0%, 1% and 2% increase,***" , to read as follows:

- (d) That Police, Library and Conservation Authorities target a 2020 tax operating budget guideline, ***which emulates the three (3) scenarios being reviewed by the City, being a 0%, 1% and 2% increase,*** and that any increase beyond the guideline be forwarded for consideration with explanation;

Result: Motion DEFEATED by a vote of 7 to 6, as follows:

YES - Councillor Maureen Wilson
YES - Councillor Jason Farr
YES - Councillor Nrinder Nann
NOT PRESENT - Councillor Sam Merulla

NO - Councillor Chad Collins
 NO - Councillor Tom Jackson
 NO - Councillor Esther Pauls
 YES - Councillor John-Paul Danko
 NO - Deputy-Mayor Lloyd Ferguson
 NO - Mayor Fred Eisenberger
 NO - Councillor Judi Partridge
 NOT PRESENT - Councillor Terry Whitehead
 NOT PRESENT - Councillor Arlene VanderBeek
 YES - Councillor Brenda Johnson
 NO - Councillor Maria Pearson
 YES - Councillor Brad Clark

(Collins/Farr)

- (a) That sub-section (f) to Report FCS19054, respecting the 2020 Budget Guidelines, Outlook and Process, be amended by deleting the words “a 0.13% increase for capital financing of West Harbour Development (WH) for a total of 1.3% tax increase”, to read as follows:
- (f) That the 2020 Tax Capital budget be submitted with a 0.5% tax increase for capital financing of discretionary block funded projects; an additional 0.26% tax increase for capital financing of Public Transit Infrastructure Fund (PTIF) projects; an additional 0.23% for DC Exemptions; and, an additional 0.14% increase for capital financing of the Downtown Office Accommodation Strategy; and, ~~a 0.13% increase for capital financing of West Harbour Development (WH) for a total of 1.3% tax increase;~~
- (b) That a new sub-section (h) be added to Report FCS19054, respecting the 2020 Budget Guidelines, Outlook and Process, to read as follows:
- (h) ***That the matter of a 0.13% increase for capital financing of West Harbour Development (WH) for a total of 1.3% tax increase, be referred to the West Harbour Development Sub-Committee for consideration;***

Result: AMENDMENT CARRIED by a vote of 13 to 0, as follows:

YES - Councillor Maureen Wilson
 YES - Councillor Jason Farr
 YES - Councillor Nrinder Nann
 NOT PRESENT - Councillor Sam Merulla

YES - Councillor Chad Collins
 YES - Councillor Tom Jackson
 YES - Councillor Esther Pauls
 YES - Councillor John-Paul Danko
 YES - Deputy-Mayor Lloyd Ferguson
 YES - Mayor Fred Eisenberger
 YES - Councillor Judi Partridge
 NOT PRESENT - Councillor Terry Whitehead
 NOT PRESENT - Councillor Arlene VanderBeek
 YES - Councillor Brenda Johnson
 YES - Councillor Maria Pearson
 YES - Councillor Brad Clark

(Ferguson/Jackson)

That a new sub-section (i) be added to Report FCS19054, respecting the 2020 Budget Guidelines, Outlook and Process, to read as follows:

- (i) *That staff be directed to report back to the General Issues Committee, with an alternative funding strategy that would reflect the commitment to transit by senior levels of government.***

Result: *AMENDMENT CARRIED* by a vote of 12 to 1, as follows:

NO - Councillor Maureen Wilson
 YES - Councillor Jason Farr
 YES - Councillor Nrinder Nann
 NOT PRESENT - Councillor Sam Merulla
 YES - Councillor Chad Collins
 YES - Councillor Tom Jackson
 YES - Councillor Esther Pauls
 YES - Councillor John-Paul Danko
 YES - Deputy-Mayor Lloyd Ferguson
 YES - Mayor Fred Eisenberger
 YES - Councillor Judi Partridge
 NOT PRESENT - Councillor Terry Whitehead
 NOT PRESENT - Councillor Arlene VanderBeek
 YES - Councillor Brenda Johnson
 YES - Councillor Maria Pearson
 YES - Councillor Brad Clark

(h) DISCUSSION ITEMS (Item 10)

(i) Business Improvement Area Advisory Committee Report 19-006, June 11, 2019 (Item 10.2)

(Pearson/Johnson)

That Item 1 of the Business Improvement Area Advisory Committee Report 19-006, June 11, 2019, be TABLED until such time as the City of Hamilton has a signed agreement with the Hamilton Tiger Cats for the 2021 Grey Cup.

1. Business Improvement Area Advisory Committee Working Group for the 2021 Grey Cup (Added Item 8.1)

That a Business Improvement Area working group be established to work with the Hamilton Tiger-Cats Football Club for the 2021 Grey Cup.

Result: Motion carried by a vote of 12 to 0, as follows:

YES - Councillor Maureen Wilson
 YES - Councillor Jason Farr
 YES - Councillor Nrinder Nann
 NOT PRESENT - Councillor Sam Merulla
 YES - Councillor Chad Collins
 YES - Councillor Tom Jackson
 YES - Councillor Esther Pauls
 YES - Councillor John-Paul Danko
 YES - Deputy-Mayor Lloyd Ferguson
 YES - Mayor Fred Eisenberger
 YES - Councillor Judi Partridge
 NOT PRESENT - Councillor Terry Whitehead
 NOT PRESENT - Councillor Arlene VanderBeek
 YES - Councillor Brenda Johnson
 NOT PRESENT - Councillor Maria Pearson
 YES - Councillor Brad Clark

(ii) Airport Sub-Committee Report 19-003, June 21, 2019 (Item 10.3)

(Danko/Nann)

That the Airport Sub-Committee Report 19-003, be moved up on the agenda to be addressed immediately after Item 8.2.

Result: Motion DEFEATED by a vote of 8 to 5, as follows:

YES - Councillor Maureen Wilson
 YES - Councillor Jason Farr

YES - Councillor Nrinder Nann
NOT PRESENT - Councillor Sam Merulla
NO - Councillor Chad Collins
NO - Councillor Tom Jackson
YES - Councillor Esther Pauls
YES - Councillor John-Paul Danko
NO - Deputy-Mayor Lloyd Ferguson
NO - Mayor Fred Eisenberger
NO - Councillor Judi Partridge
NOT PRESENT - Councillor Terry Whitehead
NO - Councillor Arlene VanderBeek
NOT PRESENT - Councillor Brenda Johnson
NO - Councillor Maria Pearson
NO - Councillor Brad Clark

(Danko/Nann)

That Item (e)(i), respecting Vantage Airport Group Climate Change Initiative, be lifted from the Information Section and added as Item 4 to the Airport Sub-Committee Report 19-003:

(i) Vantage Airport Group Climate Change Initiative (Item 11.1)

WHEREAS, the City of Hamilton has declared a climate emergency with a mandate to achieve net zero carbon emissions before 2050;

WHEREAS, TradePort International Corporation as a subsidiary of Vantage Airport Group has a mandate from the City of Hamilton to operate John C. Munro Hamilton International Airport and grow passenger and cargo volumes in order to maximize the economic potential of the airport and surrounding Airport Employment Growth District (AEGD);

WHEREAS, the City of Hamilton is currently in negotiations to extend the current Head Lease between the City and TradePort (Vantage Airport Group);

WHEREAS, the City of Hamilton recognizes that climate action and the low-carbon transition represents a massive opportunity for economic stimulation and growing job opportunities in the new low-carbon economy;

WHEREAS, air travel and air cargo have a significant inherent carbon footprint;

WHEREAS, John C. Munro Hamilton International Airport is ranked as North America's fastest growing airport and is known as Canada's busiest overnight express cargo airport;

WHEREAS, air travel passengers and air cargo consumers are increasingly concerned about the carbon footprint of their consumption choices;

WHEREAS, Greater Moncton Romeo LeBlanc International Airport under management by Vantage Airport Group has achieved Airport Carbon Accreditation Level 2 – Reduction and is working towards Level 3 – Optimization;

WHEREAS, increased uncertainty, severity and frequency of extreme weather events as a result of climate change have been observed in the Hamilton area and are projected to increase into the future;

WHEREAS, air travel and air cargo operations are vulnerable to unforeseen severe weather events and disruptions caused by such events could result in significant travel disruptions and monetary losses; and,

WHEREAS, London Luton Airport and Cardiff Airport as comparator airports have commissioned climate change studies to identify the resiliency of their operations to future climate change impacts;

THEREFORE, BE IT RESOLVED:

- (a) That the City of Hamilton request that Vantage Airport Group commit to the implementation of the four stage Airport Carbon Accreditation program (or agreed alternative) at John C. Munro Hamilton International Airport, with the goal of achieving net-zero carbon emissions before 2050;
- (b) That the City of Hamilton request that Vantage Airport Group commit to an evaluation of the resiliency and preparedness of their operations and assets due to potential climate change impacts and develop a prioritized risk assessment and adaptation plan; and,
- (c) That the City of Hamilton negotiating team include these actions as part of the current negotiations to extend the Head Lease between the City and TradePort (Vantage Airport Group).

Result: Motion DEFEATED by a vote of 6 to 5, as follows:

YES - Councillor Maureen Wilson
 YES - Councillor Jason Farr
 YES - Councillor Nrinder Nann
 NOT PRESENT - Councillor Sam Merulla
 YES - Councillor Chad Collins
 NO - Councillor Tom Jackson
 NO - Councillor Esther Pauls
 YES - Councillor John-Paul Danko
 NO - Deputy-Mayor Lloyd Ferguson
 NOT PRESENT - Mayor Fred Eisenberger
 NO - Councillor Judi Partridge
 NOT PRESENT - Councillor Terry Whitehead
 NOT PRESENT - Councillor Arlene VanderBeek
 NO - Councillor Brenda Johnson
 NO - Councillor Maria Pearson
 NOT PRESENT - Councillor Brad Clark

(iii) Affordable Housing Site Selection Sub-Committee Report 19-001, June 18, 2019 (Item 10.5)

(Collins/Partridge)

That sub-section (e) to the Affordable Housing Site Selection Sub-Committee Report 19-001, which reads as follows, be deferred to the August 12, 2019 General Issues Committee:

(e) Disposition Strategy - Portion of Wentworth Lodge Lands (PED19138) (Ward 13) (Item 14.3)

That the entirety of Report PED19138, respecting Disposition Strategy - Portion of Wentworth Lodge Lands, remain confidential.

Result: AMENDMENT CARRIED by a vote of 11 to 0, as follows:

YES - Councillor Maureen Wilson
 YES - Councillor Jason Farr
 YES - Councillor Nrinder Nann
 NOT PRESENT - Councillor Sam Merulla
 YES - Councillor Chad Collins
 YES - Councillor Tom Jackson
 YES - Councillor Esther Pauls
 YES - Councillor John-Paul Danko
 YES - Deputy-Mayor Lloyd Ferguson
 NOT PRESENT - Mayor Fred Eisenberger
 YES - Councillor Judi Partridge

NOT PRESENT - Councillor Terry Whitehead
 NOT PRESENT - Councillor Arlene VanderBeek
 YES - Councillor Brenda Johnson
 YES - Councillor Maria Pearson
 NOT PRESENT - Councillor Brad Clark

**(iv) Hate Related Activities on City of Hamilton Properties (LS19031/PW19068)
(City Wide) (Item 10.10)**

(Clark/Eisenberger)

That a new subsection (i) be added to Report LS19031/PW19068, respecting Hate Related Activities on City of Hamilton Properties, to read as follows:

- (i) That Legal staff be directed to contact Police or the Crown Attorney to determine if the City could issue prohibition to attend at municipal properties; specifically, the Hamilton City Hall Forecourt, as part of their condition of release via standard bail conditions or parole conditions, if convicted.

Result: *AMENDMENT CARRIED* by a vote of 12 to 0, as follows:

YES - Councillor Maureen Wilson
 YES - Councillor Jason Farr
 YES - Councillor Nrinder Nann
 NOT PRESENT - Councillor Sam Merulla
 YES - Councillor Chad Collins
 YES - Councillor Tom Jackson
 YES - Councillor Esther Pauls
 YES - Councillor John-Paul Danko
 YES - Deputy-Mayor Lloyd Ferguson
 YES - Mayor Fred Eisenberger
 YES - Councillor Judi Partridge
 NOT PRESENT - Councillor Terry Whitehead
 NOT PRESENT - Councillor Arlene VanderBeek
 YES - Councillor Brenda Johnson
 NOT PRESENT - Councillor Maria Pearson
 YES - Councillor Brad Clark

(i) MOTIONS (Item 11)

(Jackson/Nann)

That, as there are many delegates present respecting Item 11.1 being the Motion respecting Modifications to the Guidelines and Criteria for the Barton/Kenilworth Tax Increment Grant Program; the Barton/Kenilworth Commercial Corridor Building Improvement Grant Program; the Barton/Kenilworth Commercial

Planning and Building Fee Rebate Program; the Commercial Corridor Housing Loan and Grant Program; and, the Hamilton Tax Increment Grant Program, Item 11.1 be moved up on the agenda, to be addressed prior to the Discussion Items on the agenda.

Result: Motion CARRIED by a vote of 9 to 1, as follows:

YES - Councillor Maureen Wilson
 YES - Councillor Jason Farr
 YES - Councillor Nrinder Nann
 NOT PRESENT - Councillor Sam Merulla
 YES - Councillor Chad Collins
 YES - Councillor Tom Jackson
 YES - Councillor Esther Pauls
 YES - Councillor John-Paul Danko
 YES - Deputy-Mayor Lloyd Ferguson
 YES - Mayor Fred Eisenberger
 NOT PRESENT - Councillor Judi Partridge
 NOT PRESENT - Councillor Terry Whitehead
 CONFLICT - Councillor Arlene VanderBeek
 NOT PRESENT - Councillor Brenda Johnson
 CONFLICT - Councillor Maria Pearson
 NO - Councillor Brad Clark

- (i) **Modifications to the Guidelines and Criteria for the Barton/Kenilworth Tax Increment Grant Program; the Barton/Kenilworth Commercial Corridor Building Improvement Grant Program; the Barton/Kenilworth Commercial Planning and Building Fee Rebate Program; the Commercial Corridor Housing Loan and Grant Program; and, the Hamilton Tax Increment Grant Program (Item 11.1)**

(Nann/Pauls)

WHEREAS, the City of Hamilton's Strategic Plan recognizes and supports the need for affordable housing units as one of the City's top priorities;

WHEREAS, the City's financial incentive programs delivered through the Economic Development Division, which include: the Barton/Kenilworth Tax Increment Grant Program; the Barton/Kenilworth Commercial Corridor Building Improvement Grant Program; the Barton/Kenilworth Commercial Planning and Building Fee Rebate Program; the Commercial Corridor Housing Loan and Grant Program; and, the Hamilton Tax Increment Grant Program, were created to provide an economic catalyst for developing, redeveloping or renovating residential/commercial lands and buildings within Downtown Hamilton; Community Downtowns; the Mount Hope/Airport Gateway; Business Improvement Areas and "Commercial

Corridors”, including the Barton and Kenilworth Commercial Corridors; and, the properties that front onto Barton Street between James Street North and Victoria Avenue North, as identified in the Downtown and Community Renewal Community Improvement Project Area;

WHEREAS, these incentive programs have contributed to the creation of approximately 700 new residential dwelling units and 134 renovated dwelling units since 2002;

WHEREAS, these incentives require that all residential units meet current property standards, fire code standards, and proper zoning as well as building code requirements; thereby, creating safe and legal residential dwelling units;

WHEREAS, these incentive programs continue to provide an important means by which the City is helping to increase housing supply in Hamilton;

WHEREAS, there is community concern that there is the potential that the property improvements supported by these incentive programs could potentially contribute to the displacement of vulnerable tenants;

THEREFORE, BE IT RESOLVED:

- (a) That staff be directed to consult with any interested Ward Councillors and with any stakeholders who request to meet with staff, and that staff then prepare potential modifications to the guidelines and criteria for the Barton/Kenilworth Tax Increment Grant Program; the Barton/Kenilworth Commercial Corridor Building Improvement Grant Program; the Barton/Kenilworth Commercial Planning and Building Fee Rebate Program; the Commercial Corridor Housing Loan and Grant Program; and, the Hamilton Tax Increment Grant Program that would address the following issues:
 - (i) That any property improvements funded by these incentive programs do not result in the permanent displacement of an existing tenant, as a result of the improvement;
 - (ii) Tenants are provided full and comprehensive information, verified by, and in consultation with Housing Services staff, regarding their legal rights if any property improvements that are funded by these incentive programs have the potential to disrupt or impact the tenants;
 - (iii) The explicit value and nature of the City’s financial contribution to any property improvement is disclosed to the

Landlord and Tenant Board in any matter involving an application for an above-guideline rent increase; and,

- (b) That staff be directed to report back to a future General Issues Committee meeting with the potential changes to the guidelines and criteria for the Barton/Kenilworth Tax Increment Grant Program; the Barton/Kenilworth Commercial Corridor Building Improvement Grant Program; the Barton/Kenilworth Commercial Planning and Building Fee Rebate Program; the Commercial Corridor Housing Loan and Grant Program; and, the Hamilton Tax Increment Grant Program, for Committee's consideration.

Result: Motion CARRIED by a vote of 11 to 0, as follows:

YES - Councillor Maureen Wilson
 YES - Councillor Jason Farr
 YES - Councillor Nrinder Nann
 NOT PRESENT - Councillor Sam Merulla
 YES - Councillor Chad Collins
 YES - Councillor Tom Jackson
 YES - Councillor Esther Pauls
 YES - Councillor John-Paul Danko
 YES - Deputy-Mayor Lloyd Ferguson
 YES - Mayor Fred Eisenberger
 YES - Councillor Judi Partridge
 NOT PRESENT - Councillor Terry Whitehead
 CONFLICT - Councillor Arlene VanderBeek
 NOT PRESENT - Councillor Brenda Johnson
 CONFLICT - Councillor Maria Pearson
 YES - Councillor Brad Clark

(ii) City-Wide Stormwater Rate Program Review (Item 11.2)

(Danko/Eisenberger)

That Item 11.2, being a Motion respecting a City-Wide Stormwater Rate Program Review, be moved up on the agenda, to be addressed prior to the Discussion Items on the agenda.

Result: Motion CARRIED by a vote of 8 to 5, as follows:

YES - Councillor Maureen Wilson
 YES - Councillor Jason Farr
 YES - Councillor Nrinder Nann
 NOT PRESENT - Councillor Sam Merulla
 YES - Councillor Chad Collins

YES - Councillor Tom Jackson
YES - Councillor Esther Pauls
YES - Councillor John-Paul Danko
NO - Deputy-Mayor Lloyd Ferguson
YES - Mayor Fred Eisenberger
NO - Councillor Judi Partridge
NOT PRESENT - Councillor Terry Whitehead
NO - Councillor Arlene VanderBeek
NOT PRESENT - Councillor Brenda Johnson
NO - Councillor Maria Pearson
NO - Councillor Brad Clark

(Danko/Eisenberger)

WHEREAS, stormwater charges are currently based on usage volume of potable water consumed and are not sufficient to fund the full cost of Hamilton's stormwater infrastructure;

WHEREAS, stormwater management infrastructure is critical to control the quantity and quality of runoff, reduce flood damage and improve local water quality,

WHEREAS, climate change is resulting in more frequent, high intensity storms and elevated Lake Ontario water levels, which impact infrastructure and create challenges for residents;

WHEREAS, the City currently operates 123 stormwater management facilities and is anticipating an additional 43 to be incorporated into the inventory within the next 5 years;

WHEREAS, in 2019, the City is responding to elevated Lake Ontario water levels with temporary controls and pumping at an estimated cost \$2.5M - \$3M to minimize flooding and protect the Woodward Avenue Wastewater Treatment Plant;

WHEREAS, stormwater rates provide a dedicated, stable and fair funding source for stormwater management infrastructure and related costs and provide incentive for better private property management of stormwater runoff and pollution; and,

WHEREAS, many other municipalities in Ontario have implemented a dedicated stormwater rate to fund stormwater programs;

THEREFORE, BE IT RESOLVED:

That staff be directed to review a Stormwater Rate Program for the City of Hamilton and report back to the General Issues Committee with a framework and options for implementation.

(Eisenberger/Danko)

That the Motion respecting a City-Wide Stormwater Rate Program Review be amended by adding a new sub-section (b) to read as follows:

- (b) *That staff be directed to report back to the General Issues Committee on what the City is requiring now and to bring forward other options or incentives that can be advanced that will reduce stormwater flows.***

Result: **AMENDMENT CARRIED by a vote of 12 to 1, as follows:**

YES - Councillor Maureen Wilson
 YES - Councillor Jason Farr
 YES - Councillor Nrinder Nann
 NOT PRESENT - Councillor Sam Merulla
 YES - Councillor Chad Collins
 YES - Councillor Tom Jackson
 NO - Councillor Esther Pauls
 YES - Councillor John-Paul Danko
 YES - Deputy-Mayor Lloyd Ferguson
 YES - Mayor Fred Eisenberger
 YES - Councillor Judi Partridge
 NOT PRESENT - Councillor Terry Whitehead
 YES - Councillor Arlene VanderBeek
 NOT PRESENT - Councillor Brenda Johnson
 YES - Councillor Maria Pearson
 YES - Councillor Brad Clark

(Danko/Collins)

WHEREAS, stormwater charges are currently based on usage volume of potable water consumed and are not sufficient to fund the full cost of Hamilton's stormwater infrastructure;

WHEREAS, stormwater management infrastructure is critical to control the quantity and quality of runoff, reduce flood damage and improve local water quality,

WHEREAS, climate change is resulting in more frequent, high intensity storms and elevated Lake Ontario water levels, which impact infrastructure and create challenges for residents;

WHEREAS, the City currently operates 123 stormwater management facilities and is anticipating an additional 43 to be incorporated into the inventory within the next 5 years;

WHEREAS, in 2019, the City is responding to elevated Lake Ontario water levels with temporary controls and pumping at an estimated cost \$2.5M - \$3M to minimize flooding and protect the Woodward Avenue Wastewater Treatment Plant;

WHEREAS, stormwater rates provide a dedicated, stable and fair funding source for stormwater management infrastructure and related costs and provide incentive for better private property management of stormwater runoff and pollution; and,

WHEREAS, many other municipalities in Ontario have implemented a dedicated stormwater rate to fund stormwater programs;

THEREFORE, BE IT RESOLVED:

- (a) That staff be directed to review a Stormwater Rate Program for the City of Hamilton and report back to the General Issues Committee on the feasibility and financial implications of a framework and options for implementation; and,
- (b) ***That staff be directed to report back to the General Issues Committee on what the City is requiring now and to bring forward other options or incentives that can be advanced that will reduce stormwater flows.***

Result: MAIN MOTION, AS AMENDED, CARRIED by a vote of 10 to 3, as follows:

YES - Councillor Maureen Wilson
YES - Councillor Jason Farr
YES - Councillor Nrinder Nann
NOT PRESENT - Councillor Sam Merulla
YES - Councillor Chad Collins
YES - Councillor Tom Jackson
NO - Councillor Esther Pauls
YES - Councillor John-Paul Danko
NO - Deputy-Mayor Lloyd Ferguson
YES - Mayor Fred Eisenberger
YES - Councillor Judi Partridge
NOT PRESENT - Councillor Terry Whitehead
YES - Councillor Arlene VanderBeek
NOT PRESENT - Councillor Brenda Johnson
YES - Councillor Maria Pearson

NO - Councillor Brad Clark

(j) GENERAL INFORMATION / OTHER BUSINESS (Item 13)

(Collins/Farr)

That the following amendments to the General Issues Committee's Outstanding Business List, be approved as follows:

13.1 Proposed New Due Dates:

- 13.1.a Art in Public Places Policy
Current Due Date: August 12, 2019
Proposed New Due Date: January 15, 2020
- 13.1.b Community Benefits Protocol Advisory Committee –
Terms of Reference
Current Due Date: July 8, 2019
Proposed New Due Date: October 16, 2019
- 13.1.c MOU with Hamilton 100 confirming their Commitment to
Lead the 2030 Commonwealth Games Hosting Proposal
Current Due Date: July 8, 2019
Proposed New Due Date: August 12, 2019
- 13.1.d Code of Conduct for Council-Appointed Member of External
Boards and Agencies
Current Due Date: July 8, 2019
Proposed New Due Date: September 18, 2019
- 13.1.e Pending Litigation Matters and Associated Liabilities
Current Due Date: June 19, 2019
Proposed New Due Date: August 12, 2019
- 13.1.f Pier 8 Development Opportunity RFP – Summary of the 4
Proposals
Current Due Date: July 8, 2019
Proposed New Due Date: November 20, 2019

13.2 Items to be removed:

- 13.2.a Audit and Accountability Fund – Expression of Interest
(Addressed at the June 19, 2019 GIC (FCS19059))
- 13.2.b Celebrate Ontario 2019 Results (Addressed on today's
agenda (PED19147))

Result: Motion CARRIED by a vote of 12 to 0, as follows:

YES - Councillor Maureen Wilson
 YES - Councillor Jason Farr
 YES - Councillor Nrinder Nann
 NOT PRESENT - Councillor Sam Merulla
 YES - Councillor Chad Collins
 YES - Councillor Tom Jackson
 YES - Councillor Esther Pauls
 YES - Councillor John-Paul Danko
 YES - Deputy-Mayor Lloyd Ferguson
 YES - Mayor Fred Eisenberger
 YES - Councillor Judi Partridge
 NOT PRESENT - Councillor Terry Whitehead
 NOT PRESENT - Councillor Arlene VanderBeek
 YES - Councillor Brenda Johnson
 NOT PRESENT - Councillor Maria Pearson
 YES - Councillor Brad Clark

(k) PRIVATE & CONFIDENTIAL (Item 14)

(i) Closed Session Minutes – June 19, 2019 (Item 14.1)

(Partridge/VanderBeek)

- (a) That the Closed Session Minutes of the June 19, 2019 General Issues Committee meeting, be approved; and,
- (b) That the Closed Session Minutes of the June 19, 2019 General Issues Committee meeting remain confidential.

Result: Motion CARRIED by a vote of 11 to 0, as follows:

YES - Councillor Maureen Wilson
 YES - Councillor Jason Farr
 YES - Councillor Nrinder Nann
 NOT PRESENT - Councillor Sam Merulla
 NOT PRESENT - Councillor Chad Collins
 YES - Councillor Tom Jackson
 YES - Councillor Esther Pauls
 YES - Councillor John-Paul Danko
 YES - Deputy-Mayor Lloyd Ferguson
 YES - Mayor Fred Eisenberger
 YES - Councillor Judi Partridge
 NOT PRESENT - Councillor Terry Whitehead
 NOT PRESENT - Councillor Arlene VanderBeek
 YES - Councillor Brenda Johnson

NOT PRESENT - Councillor Maria Pearson
YES - Councillor Brad Clark

(Partridge/Clark)

That Committee move into Closed Session respecting Items 14.2 to 14.4, pursuant to Section 8.1, Sub-sections (c), (e) and (f) of the City's Procedural By-law 18-270, and Section 239(2), Sub-sections (c), (e) and (f) of the Ontario Municipal Act, 2001, as amended, as the subject matters pertain to a proposed or pending acquisition or disposition of land; litigation or potential litigation, including matters before administrative tribunals, affecting the City; and, the receiving of advice that is subject to solicitor-client privilege, including communications necessary for that purpose.

Result: Motion CARRIED by a vote of 9 to 0, as follows:

YES - Councillor Maureen Wilson
NOT PRESENT - Councillor Jason Farr
YES - Councillor Nrinder Nann
NOT PRESENT - Councillor Sam Merulla
NOT PRESENT - Councillor Chad Collins
YES - Councillor Tom Jackson
YES - Councillor Esther Pauls
YES - Councillor John-Paul Danko
YES - Deputy-Mayor Lloyd Ferguson
NOT PRESENT - Mayor Fred Eisenberger
YES - Councillor Judi Partridge
NOT PRESENT - Councillor Terry Whitehead
NOT PRESENT - Councillor Arlene VanderBeek
YES - Councillor Brenda Johnson
NOT PRESENT - Councillor Maria Pearson
YES - Councillor Brad Clark

(I) ADJOURNMENT (Item 13)

(Clark/Farr)

That there being no further business, the General Issues Committee be adjourned at 6:51 p.m.

CARRIED

Respectfully submitted,

L. Ferguson, Deputy Mayor
Chair, General Issues Committee

Stephanie Paparella
Legislative Coordinator,
Office of the City Clerk

6.1

Form: Request to Speak to Committee of Council
Submitted on Wednesday, July 10, 2019 - 12:35 pm

==Committee Requested==

Committee: General Issues Committee

==Requestor Information==

Name of Individual: Michael Van Pelt

Name of Organization: Cardus

Contact Number: 905-464-3687

Email Address: mvanpelt@cardus.ca

Mailing Address:

185 Young St
Hamilton ON L8N 1V9
Canada

Reason(s) for delegation request: Discuss staff report regarding Balfour House submitted by Ian Kerr-Wilson, Manager, Heritage Resource Management

Will you be requesting funds from the City? No

Will you be submitting a formal presentation? Yes

6.2

Form: Request to Speak to Committee of Council

Submitted on Thursday, August 8, 2019 - 9:28 pm

==Committee Requested==

Committee: General Issues Committee

==Requestor Information==

Name of Individual: PJ Mercanti, S. Jasper Kujavsky, Greg Maychak, Mark Wu

Name of Organization: Hamilton100 Commonwealth Games Bid Corporation

Contact Number: 905-512-9393

Email Address: jasper@Hamilton100.ca

Mailing Address:

300 - 77 James Street North

Hamilton, Ontario

L8K 2K3

Reason(s) for delegation request:

- 1) To express support for, and answer any questions regarding, the staff recommendation to Council on the proposed MOU between the City and Hamilton100;
- 2) To update Council on the Commonwealth Games Federation and Commonwealth Games Canada recent site visit to Hamilton; and
- 3) To update Council on the proposed launch of Hamilton100's website and social media presence.

Will you be requesting funds from the City? No

Will you be submitting a formal presentation? No

6.3

Form: Request to Speak to Committee of Council

Submitted on Friday, August 9, 2019 - 12:36 am

==Committee Requested==

Committee: General Issues Committee

==Requestor Information==

Name of Individual: David Bennett

Name of Organization: Hamilton 350

Contact Number:

Email Address:

Mailing Address: C/O Environment Hamilton, 22 Wilson St.,
Ste. 4, Hamilton, ON L8R 1C5

Reason(s) for delegation request: Request to speak to GIC re Climate Emergency, including items 10.3 & 10.4 on agenda for Monday August 12th., 2019 and earlier council decisions regarding airport carbon accreditation and pipeline construction.

Will you be requesting funds from the City? No

Will you be submitting a formal presentation? Yes



CITY OF HAMILTON
PLANNING AND ECONOMIC DEVELOPMENT DEPARTMENT
Economic Development Division

TO:	Mayor and Members General Issues Committee
COMMITTEE DATE:	August 12, 2019
SUBJECT/REPORT NO:	Revised Board of Management for the Concession Street Business Improvement Area (BIA) (PED19155) (Wards 7 and 8)
WARD(S) AFFECTED:	Wards 7 and 8
PREPARED BY:	Julia Davis (905) 546-2424 Ext. 2632
SUBMITTED BY:	Glen Norton Director, Economic Development Planning and Economic Development Department
SIGNATURE:	

RECOMMENDATION

That the following individuals be appointed to the Concession Street Business Improvement Area (BIA) Board of Management:

- (i) Julie Noble

EXECUTIVE SUMMARY

Appointment of Board Members to the Concession Street Business Improvement Area (BIA) Board of Management

Alternatives for Consideration – N/A

FINANCIAL – STAFFING – LEGAL IMPLICATIONS

Financial: N/A

Staffing: N/A

Legal: The *Municipal Act 2001*, Sections 204-215 governs BIAs. Section (204) Subsection (3) stipulates “A Board of Management shall be composed of, (a) one or more Directors appointed directly by the Municipality; and (b) the remaining Directors selected by a vote of the membership of the improvement area and appointed by the Municipality”. Section 204 Subsection (12) stipulates “...if a vacancy occurs for any cause, the Municipality may appoint

OUR Vision: To be the best place to raise a child and age successfully.

OUR Mission: To provide high quality cost conscious public services that contribute to a healthy, safe and prosperous community, in a sustainable manner.

OUR Culture: Collective Ownership, Steadfast Integrity, Courageous Change, Sensational Service, Engaged Empowered Employees.

SUBJECT: Revised Board of Management for the Concession Street Business Improvement Area (BIA) (PED19155) (Wards 7 and 8) - Page 2 of 2

a person to fill the vacancy for the unexpired portion of the term and the appointed person is not required to be a member of the improvement area.”

HISTORICAL BACKGROUND

A meeting of the Board of Management of the Concession Street BIA took place on June 20, 2019. At this meeting, the membership nominated Julie Noble to the position of Director on the Board of Management.

Should Council adopt the recommendation in Report PED19155, the aforementioned nominated BIA members would replace Mike DeVries as Director who resigned from on the BIA Board of Management.

POLICY IMPLICATIONS AND LEGISLATED REQUIREMENTS

N/A

RELEVANT CONSULTATION

N/A

ANALYSIS AND RATIONALE FOR RECOMMENDATION

N/A

ALTERNATIVES FOR CONSIDERATION

N/A

ALIGNMENT TO THE 2016 – 2025 STRATEGIC PLAN

Community Engagement and Participation

Hamilton has an open, transparent and accessible approach to City government that engages with and empowers all citizens to be involved in their community.

Economic Prosperity and Growth

Hamilton has a prosperous and diverse local economy where people have opportunities to grow and develop.

APPENDICES AND SCHEDULES ATTACHED

N/A

JD:dt



CITY OF HAMILTON
PLANNING AND ECONOMIC DEVELOPMENT DEPARTMENT
Economic Development Division

TO:	Mayor and Members General Issues Committee
COMMITTEE DATE:	August 12, 2019
SUBJECT/REPORT NO:	Revised Board of Management for the Locke Street Business Improvement Area (BIA) (PED19156) (Ward 1)
WARD(S) AFFECTED:	Ward 1
PREPARED BY:	Julia Davis (905) 546-2424 Ext. 2632
SUBMITTED BY:	Glen Norton Director, Economic Development Planning and Economic Development Department
SIGNATURE:	

RECOMMENDATION

That the following individuals be appointed to the Locke Street Business Improvement Area (BIA) Board of Management:

- (i) Ryan Furlong
- (ii) Steve Knight

EXECUTIVE SUMMARY

Appointments to the Locke Street Business Improvement Area (BIA) Board of Management.

Alternatives for Consideration – N/A

FINANCIAL – STAFFING – LEGAL IMPLICATIONS

Financial: N/A

Staffing: N/A

Legal: The *Municipal Act 2001*, Sections 204-215 governs BIAs. Section (204) Subsection (3) stipulates “A Board of Management shall be composed of, (a) one or more Directors appointed directly by the Municipality; and (b) the remaining Directors selected by a vote of the membership of the improvement area and appointed by the Municipality”. Section 204 Subsection (12)

OUR Vision: To be the best place to raise a child and age successfully.

OUR Mission: To provide high quality cost conscious public services that contribute to a healthy, safe and prosperous community, in a sustainable manner.

OUR Culture: Collective Ownership, Steadfast Integrity, Courageous Change, Sensational Service, Engaged Empowered Employees.

SUBJECT: Revised Board of Management for the Locke Street Business Improvement Area (BIA) (PED19156) (Ward 1) - Page 2 of 2

stipulates "...if a vacancy occurs for any cause, the Municipality may appoint a person to fill the vacancy for the unexpired portion of the term and the appointed person is not required to be a member of the improvement area."

HISTORICAL BACKGROUND

A meeting of the Board of Management of the Locke Street BIA took place on June 25, 2019. At this meeting, the membership nominated Ryan Furlong and Steve Knight for vacant positions on the BIA Board of Management.

Should Council adopt the recommendation in Report PED19156, the aforementioned nominated BIA members would fill vacancies as Directors on the BIA Board of Management.

POLICY IMPLICATIONS AND LEGISLATED REQUIREMENTS

N/A

RELEVANT CONSULTATION

N/A

ANALYSIS AND RATIONALE FOR RECOMMENDATION

N/A

ALTERNATIVES FOR CONSIDERATION

N/A

ALIGNMENT TO THE 2016 – 2025 STRATEGIC PLAN

Community Engagement and Participation

Hamilton has an open, transparent and accessible approach to City government that engages with and empowers all citizens to be involved in their community.

Economic Prosperity and Growth

Hamilton has a prosperous and diverse local economy where people have opportunities to grow and develop.

APPENDICES AND SCHEDULES ATTACHED

N/A

JD:dt

OUR Vision: To be the best place to raise a child and age successfully.

OUR Mission: To provide high quality cost conscious public services that contribute to a healthy, safe and prosperous community, in a sustainable manner.

OUR Culture: Collective Ownership, Steadfast Integrity, Courageous Change, Sensational Service, Engaged Empowered Employees.



CITY OF HAMILTON
PLANNING AND ECONOMIC DEVELOPMENT DEPARTMENT
Economic Development Division

TO:	Mayor and Members General Issues Committee
COMMITTEE DATE:	August 12, 2019
SUBJECT/REPORT NO:	Revised Board of Management for the Barton Village Business Improvement Area (BIA) (PED19160) (Wards 2 and 3)
WARD(S) AFFECTED:	Wards 2 and 3
PREPARED BY:	Julia Davis (905) 546-2424 Ext. 2632
SUBMITTED BY:	Glen Norton Director, Economic Development Planning and Economic Development Department
SIGNATURE:	

RECOMMENDATION

That the following individuals be appointed to the Barton Village Business Improvement Area (BIA) Board of Management:

- (i) Karen Parucha

EXECUTIVE SUMMARY

Appointments to the Barton Village Business Improvement Area (BIA) Board of Management

Alternatives for Consideration – N/A

FINANCIAL – STAFFING – LEGAL IMPLICATIONS

Financial: N/A

Staffing: N/A

Legal: The *Municipal Act 2001*, Sections 204-215 governs BIAs. Section (204) Subsection (3) stipulates “A Board of Management shall be composed of, (a) one or more Directors appointed directly by the Municipality; and (b) the remaining Directors selected by a vote of the membership of the improvement area and appointed by the Municipality”. Section 204 Subsection (12) stipulates “...if a vacancy occurs for any cause, the Municipality may appoint

OUR Vision: To be the best place to raise a child and age successfully.

OUR Mission: To provide high quality cost conscious public services that contribute to a healthy, safe and prosperous community, in a sustainable manner.

OUR Culture: Collective Ownership, Steadfast Integrity, Courageous Change, Sensational Service, Engaged Empowered Employees.

SUBJECT: Revised Board of Management for the Barton Village Business Improvement Area (BIA) (PED19160) (Wards 2 and 3) - Page 2 of 2

a person to fill the vacancy for the unexpired portion of the term and the appointed person is not required to be a member of the improvement area.”

HISTORICAL BACKGROUND

A meeting of the Board of Management of the Barton Village BIA took place on April 25, 2019. At this meeting, the membership nominated Karen Parucha for a position on the BIA Board of Management.

Should Council adopt the recommendation in Report PED19160, the aforementioned nominated BIA member would replace John MacDonald who has resigned from the Barton Village BIA Board of Management.

POLICY IMPLICATIONS AND LEGISLATED REQUIREMENTS

N/A

RELEVANT CONSULTATION

N/A

ANALYSIS AND RATIONALE FOR RECOMMENDATION

N/A

ALTERNATIVES FOR CONSIDERATION

N/A

ALIGNMENT TO THE 2016 – 2025 STRATEGIC PLAN

Community Engagement and Participation

Hamilton has an open, transparent and accessible approach to City government that engages with and empowers all citizens to be involved in their community.

Economic Prosperity and Growth

Hamilton has a prosperous and diverse local economy where people have opportunities to grow and develop.

APPENDICES AND SCHEDULES ATTACHED

N/A

JD:dt

OUR Vision: To be the best place to raise a child and age successfully.

OUR Mission: To provide high quality cost conscious public services that contribute to a healthy, safe and prosperous community, in a sustainable manner.

OUR Culture: Collective Ownership, Steadfast Integrity, Courageous Change, Sensational Service, Engaged Empowered Employees.



Hamilton

**ADVISORY COMMITTEE FOR PERSONS WITH
DISABILITIES**

Minutes 19-005

4:00 p.m.

Tuesday, June 11, 2019

Rooms 192 and 193, City Hall

71 Main Street West

Present: S. Aaron, J. Cardno, L. Dingman, A. Frisina, S. Geffros,
A. Mallet, C. McBride, M. McNeil, T. Murphy, K. Nolan,
T. Nolan, A. Wilson

Absent
with regrets: J. Hawker

Also Present: J. Bowen, Supervisor, Diversity and Inclusion
Sergeant S. Moore, Hamilton Police Service

FOR INFORMATION:

(a) APPOINTMENT OF CHAIR AND VICE-CHAIR (Item 1)

The vote to select a Chair and Vice-Chair was taken by ballot, in violation of the Section 244 of the Municipal Act, 2001 and Section 3.13 (11) of the Procedural By-law 18-270. As such, the ballot votes taken at the Committee meeting are null and void and will be retaken and voted on by show of hands at the July 9, 2019 meeting.

(b) CHANGES TO THE AGENDA (Item 2)

The Committee Clerk advised of the following changes to the agenda:

1. STAFF PRESENTATIONS**9.2. Media Best Practices**

Staff requested to be moved up on the agenda to be considered immediately following Item 4.1.

2. DISCUSSION ITEMS**10.4. Notice of Ministry Training Webinar for Municipal Accessibility Advisory Committees****(Cardno/McNeil)**

That the agenda for the June 11, 2019 meeting of the Advisory Committee for Persons with Disabilities be approved, as amended.

CARRIED**(c) DECLARATIONS OF INTEREST (Item 3)**

There were no declarations of interest.

(d) APPROVAL OF MINUTES (Item 4)**(i) May 14, 2019 (Item 4.1)****(T. Nolan/Cardno)**

That the minutes of the May 14, 2019 meeting of the Advisory Committee for Persons with Disabilities, be approved, as presented.

CARRIED

(e) STAFF PRESENTATIONS (Item 9)

(i) Media Best Practices (Item 9.2)

Jacqueline Durlov, Communications Officer, addressed the Committee respecting Media Best Practices, with the aid of a presentation.

(T. Nolan/Dingman)

That the presentation, respecting Media Best Practices, be received.

CARRIED

A copy of the presentation is available on the City's website at www.hamilton.ca or through the Office of the City Clerk.

(f) COMMUNICATIONS (Item 5)

(i) Correspondence from Jamie McGarvey, AMO President, in Response to the Mayor's Letter respecting Council's Resolution Requesting Support for a Pilot Program for the City of Hamilton to Meet AODA Requirements and to Prioritize Accessibility Priorities in Canada and Ontario Infrastructure Programs (referred from Council – May 8 & 9, 2019) (Item 5.1)

(Cardno/K. Nolan)

That the correspondence from Jamie McGarvey, AMO President, in Response to the Mayor's Letter respecting Council's Resolution Requesting Support for a Pilot Program for the City of Hamilton to Meet AODA Requirements and to Prioritize Accessibility Priorities in Canada and Ontario Infrastructure Programs, be received.

CARRIED

(g) CONSENT ITEMS (Item 7)

- (i) Transportation Working Group Meeting Notes - April 30, 2019 (Item 7.1)**

(K. Nolan/McNeil)

That the Transportation Working Group Notes of April 30, 2019, be received.

CARRIED

(h) STAFF PRESENTATIONS – CONTINUED (Item 9)

- (i) Orientation for the Advisory Committee for Persons with Disabilities (Item 9.1)**

A training video for City of Hamilton Committee Members was shown. The video can be accessed via the following link: <https://youtu.be/X-o4EeOxFE0>

Jessica Bowen, Supervisor, Diversity and Inclusion, addressed the Committee respecting the City's Harassment and Discrimination Prevention Policy and the Accessibility for Ontarians with Disabilities Act (AODA), with the aid of a presentation.

A copy of the presentation is available on the City's website at www.hamilton.ca or through the Office of the City Clerk.

(K. Nolan/McNeil)

That the training video and presentation, respecting an Orientation for the Advisory Committee for Persons with Disabilities, be received.

CARRIED

(i) DISCUSSION ITEMS (Item 10)**(T. Nolan/Wilson)**

That the following discussion items be deferred to the July 9, 2019 Advisory Committee for Persons with Disabilities meeting due to time constraints:

- (i) Establishment of Working Group Memberships (Item 10.1)
- (ii) Advisory Committee for Persons with Disabilities Budget (Item 10.2)
- (iii) Appointment of Greater Toronto and Hamilton Area Accessibility Advisory Committee (GTHA AAC) Representative (Item 10.3)
- (iv) Notice of Ministry Training Webinar for Municipal Accessibility Advisory Committees (Item 10.4)

(j) ADJOURNMENT (Item 15)**(Geffros/Wilson)**

That there being no further business, the Advisory Committee for Persons with Disabilities be adjourned at 5:59 p.m.

CARRIED

Respectfully submitted,

Alicia Davenport
Legislative Coordinator
Office of the City Clerk



**Hamilton-Wentworth District School Board
Liaison Committee
REPORT 19-002
Thursday, June 27, 2019
12:30 p.m.
Education Centre, Room 340-B
20 Education Court, Hamilton**

Present: Mayor F. Eisenberger (Co-Chair)
A. Johnstone, Chair, HWDSB (Co-Chair)
Councillor J. Partridge
P. Deathe, Trustee, HWDSB
C. Galindo, Trustee, HWDSB

**Absent with
Regrets:** T. Rezvan, Student Trustee, HWDSB
C. Prosic, Student Trustee, HWDSB

**THE HAMILTON-WENTWORTH DISTRICT SCHOOL BOARD LIAISON COMMITTEE
PRESENTS REPORT 19-002 AND RESPECTFULLY RECOMMENDS:**

1. Parkland Dedication/Cash in Lieu for Schools (PED19143) (City Wide) (Item 10.1)

That Report PED19143, respecting Parkland Dedication/Cash-in-Lieu for Schools, be received.

FOR INFORMATION:

(a) APPROVAL OF THE AGENDA (Item 2)

The Committee Clerk advised that there were no changes to the agenda.

The agenda for the June 27, 2019 meeting of the Hamilton-Wentworth District School Board Liaison Committee was approved, as presented.

(b) DECLARATIONS OF INTEREST (Item 3)

There were no declarations of interest.

(c) APPROVAL OF MINUTES OF PREVIOUS MEETING (Item 4)**(i) April 11, 2019 (Item 4.1)**

The Minutes of the April 11, 2019 meeting of the Hamilton-Wentworth District School Board Liaison Committee were approved, as presented.

(d) CONSENT ITEMS (Item 7)**(i) Minutes of the Joint Property Assessment Committee (Item 7.1)**

The following minutes of the Joint Property Assessment Committee, were received:

- (a) April 9, 2018
- (b) June 4, 2018
- (c) October 9, 2018
- (d) January 7, 2019
- (e) April 1, 2019

(e) DISCUSSION ITEMS (Item 10)**(i) Status of City of Hamilton and HWDSB Property Agreements (Item 10.2)**

The report, respecting the status of City of Hamilton and HWDSB property agreements, was received.

(ii) New School Construction (Item 10.3)

The report respecting new school construction was received.

(f) GENERAL INFORMATION/OTHER BUSINESS (Item 13)**(i) Amendments to the Outstanding Business List (Item 13.1)**

The following amendments to the HWDSB Liaison Committee's Outstanding Business List, were approved:

- (a) Items to be removed:

- (i) Dominic Agostino Riverdale Community Hub Proposal (HSC18029)
(Addressed as Item 10.1 on the April 11, 2019 agenda)
- (ii) Parkland Dedication/Cash-in-Lieu for Schools (City Wide) (PED19143)
(Addressed as Item 10.1 on today's agenda)

(g) PRIVATE & CONFIDENTIAL (Item 14)

(i) Closed Session Minutes – April 11, 2019 (Item 14.1)

- (a) The Closed Session Minutes of the April 11, 2018 Hamilton-Wentworth District School Board Liaison Committee meeting, were approved, as presented; and,
- (b) The Closed Session Minutes of the April 11, 2018 Hamilton-Wentworth District School Board Liaison Committee meeting, are to remain confidential.

(h) ADJOURNMENT (Item 15)

There being no further business, the meeting of the HWDSB Liaison Committee was adjourned at 1:38 p.m.

Respectfully submitted,

Alex Johnstone, Co-Chair,
Hamilton Wentworth District School
Board Liaison Committee

Lisa Chamberlain
Legislative Coordinator
Office of the City Clerk



Hamilton

BUSINESS IMPROVEMENT AREA ADVISORY COMMITTEE

REPORT 19-007

8:00 a.m.

Tuesday, July 9, 2019

Rooms 192 & 193

Hamilton City Hall

71 Main Street West

Present: Councillor Esther Pauls (Chair)
 Rachel Braithwaite – Barton Village BIA
 Tracy MacKinnon – Westdale Village BIA and Stoney Creek BIA
 Susie Braithwaite – International Village BIA
 Jennifer Mattern – Ancaster BIA
 Heidi VanderKwaak – Locke Street BIA
 Bender Chug – Main West Esplanade BIA
 Susan Pennie – Waterdown BIA
 Kerry Jarvi – Downtown Hamilton BIA

Absent: Cristina Geissler – Concession Street BIA
 Anne Marie Bergen – King West BIA
 Catherine Johnston – Ottawa Street BIA
 Lisa Anderson – Dundas BIA

THE BUSINESS IMPROVEMENT AREA ADVISORY COMMITTEE PRESENTS REPORT 19-007 AND RESPECTFULLY RECOMMENDS:

1. Ancaster Village Business Improvement Area Expenditure Request (Item 11.1)

That the expenditure request from the Ancaster Village Business Improvement Area in the amount of \$5,778.55 for spending on flower planters and baskets to be funded from the Community Improvement Plan (CIP) Contribution Program (BIA Payments Account 815010-56905); be approved.

2. International Village Business Improvement Area Expenditure Request (Added Item 11.2)

That the expenditure request from the International Village Business Improvement Area in the amount of \$25,298.04 for the following projects, to be funded from the Shared Parking Revenue Program (Parking Revenue Account 815010-45559):

- (i) \$14,195.65 for Victorian Night in the Village; and,
- (ii) \$11,102.39 for marketing and promotion of the International Village Business Improvement Area; be approved.

FOR INFORMATION:

(a) CHANGES TO THE AGENDA (Item 2)

The Committee Clerk advised of the following changes to the agenda:

1. DISCUSSION ITEMS (Item 10)

10.3 Letter of Support for the 2SLGBTQ+ Community

2. NOTICES OF MOTION (Item 12)

12.1 International Village Business Improvement Area Expenditure Request

The agenda for the July 9, 2019 Business Improvement Area Advisory Committee meeting was approved, as presented.

(b) DECLARATIONS OF INTEREST (Item 3)

There were no declarations of interest.

(c) APPROVAL OF MINUTES OF PREVIOUS MEETING (Item 4)

(i) June 11, 2019 (Item 4.1)

The June 11, 2019 Minutes of the Business Improvement Area Advisory Committee were approved, as presented.

(d) DISCUSSION ITEMS (Item 10)

(i) Shop Small Saturday Event (Item 10.1)

The Committee discussed the Shop Small Saturday Event scheduled for November 30, 2019. Funding from the Main Street Revitalization Program has been allocated to this event for collateral for the BIA's. The Committee also discussed potential themes for promotion of the event.

The discussion respecting Shop Small Saturday Event, was received.

(ii) Small Business Week Events / Workshops (Item 10.2)

The Committee discussed the Small Business Week Events / Workshops which are scheduled for the week of October 20 – 26, 2019. Julia Davis asked for feedback as to whether the BIA's would like to have one-day seminars provided for their members. Committee members provided

suggestions on topics that would be helpful for their businesses. The Committee also discussed having posters for all of the BIA's displayed in City Hall for the week.

The discussion respecting Small Business Week Events / Workshops, was received.

(iii) Letter of Support for the 2SLGBTQ+ Community (Added Item 10.3)

The discussion respecting a Letter of Support for the 2SLGBTQ+ Community, was received.

(e) NOTICES OF MOTION (Item 12)

(i) International Village Business Improvement Area Expenditure Request (Added Item 12.1)

Susie Braithwaite introduced her notice of motion respecting the International Village Business Improvement Area Expenditure Request.

The rules of order were waived to allow for the introduction of a Motion respecting the International Village Business Improvement Area Expenditure Request.

For disposition of this mater, refer to Item 2.

(f) GENERAL INFORMATION/OTHER BUSINESS (Item 13)

(i) Update from Julia Davis, Business Development and BIA Officer (Item 13.1)

Julia Davis advised Committee that the BIA's have all received their Shared Parking Revenue and Community Improvement Plan (CIP) Contribution Program numbers. Spending requests need to be submitted in writing to Julia before the December 10, 2019 meeting.

Julia advised that she will be in contact with the individual BIAs to do a walkthrough of each BIA to see how things are going. Julia asked Committee members to contact her if they would like her to attend an upcoming Board Meeting.

Julia advised the Committee that the City is looking into purchasing a pedestrian counter to be used throughout the BIA's to track pedestrian traffic during events.

The verbal update from Julia Davis, Business Development and BIA Officer, was received.

(ii) Statements by Members (Item 13.2)

BIA Members used this opportunity to discuss matters of general interest.

The updates from Committee Members, were received.

(g) ADJOURNMENT (Item 15)

There being no further business, the Business Improvement Area Advisory Committee adjourned at 9:21 a.m.

Respectfully submitted,

Councillor Esther Pauls
Chair Business Improvement Area
Advisory Committee

Angela McRae
Legislative Coordinator
Office of the City Clerk



INFORMATION REPORT

TO:	Chair and Members General Issues Committee
COMMITTEE DATE:	August 12, 2019
SUBJECT/REPORT NO:	GRIDS 2 and Municipal Comprehensive Review – Work Plan Update (PED17010(d)) (City Wide)
WARD(S) AFFECTED:	City Wide
PREPARED BY:	Heather Travis (905) 546-2424 Ext. 4168
SUBMITTED BY:	Steve Robichaud Director, Planning and Chief Planner Planning and Economic Development Department
SIGNATURE:	

Council Direction:

N/A

Information:

This Report provides an update on GRIDS 2 (Growth Related Integrated Development Strategy) and the Municipal Comprehensive Review (MCR), including a project and work plan update, following the release of the new 2019 Growth Plan on May 2, 2019.

1.0 What is GRIDS and the Municipal Comprehensive Review?

The original GRIDS project was undertaken between 2003 and 2006 and allocated growth in the City to the year 2031. The City is undertaking an update to GRIDS, known as GRIDS 2, which is a long term growth strategy to allocate forecasted population and employment growth from 2031 to 2041. The forecasts for Hamilton project an increase of 40,000 jobs and 100,000 people between 2031 and 2041. As such, the original GRIDS must be updated to allocate the additional jobs and persons beyond 2031 (to 2041) and to determine the impact on the Infrastructure Master Plans and Development Charges By-law. A municipal comprehensive review (MCR) is a requirement of the Growth Plan for the Greater Golden Horseshoe and the Provincial Policy Statement (PPS) at the time of an Official Plan review to bring the City's Official Plans into conformity with the Provincial plans. The MCR is broad and encompasses many inter-related components, and must be completed prior to any expansion of the

OUR Vision: To be the best place to raise a child and age successfully.

OUR Mission: To provide high quality cost conscious public services that contribute to a healthy, safe and prosperous community, in a sustainable manner.

OUR Culture: Collective Ownership, Steadfast Integrity, Courageous Change, Sensational Service, Engaged Empowered Employees.

**SUBJECT: GRIDS 2 and Municipal Comprehensive Review – Work Plan Update
(City Wide) (PED17010(d)) – Page 2 of 5**

urban boundary. However, many of the studies that are required as part of the MCR are also part of a growth strategy. As such, the MCR will be completed concurrently with GRIDS 2, which has the benefit of combining the public and stakeholder consultation into one process, and efficiently using staff time and resources.

2.0 Growth Plan 2019

On May 2, 2019, A Place to Grow: Growth Plan for the Greater Golden Horseshoe (“Growth Plan, 2019”) was released.

The Growth Plan sets out minimum targets related to intensification and density which the City must plan to achieve. The Plan also identifies the criteria which must be followed when evaluating certain key planning changes such as settlement area boundary expansions and employment land conversions. Through the MCR process, the City is required to update its Official Plans to conform to the requirements of the Growth Plan by the year 2022.

Changes introduced in the Growth Plan 2019 include:

- revised minimum targets related to greenfield density and residential intensification;
- new permissions for urban boundary expansion and employment land conversion to occur outside of the MCR process;
- streamlined requirements for applying for alternative targets (if required); and,
- removal of certain MCR requirements including the completion of a housing strategy and employment strategy (though background work related to housing and employment is still required to inform the Land Needs Assessment).

3.0 GRIDS 2 / MCR – Project Update

With the release of the Growth Plan 2019, staff can move forward on the GRIDS 2 / MCR project and have updated the project work plan accordingly. Staff have been working on background work and technical studies to inform the GRIDS 2 / MCR project. With the release of the new Growth Plan, this work will need to be updated to reflect the new policy regime. Analysis related to the new minimum targets is required to determine the appropriate targets and comprehensively apply the policies of the Growth Plan for the City of Hamilton which will ultimately inform the Land Needs Assessment.

The work plan for GRIDS 2 / MCR is following a four phase approach. Phase 1, background work, was completed in 2017. The project is currently in Phase 2, which is completion of the Technical Studies noted above. Moving forward, Phase 3 will commence upon the completion of the Land Needs Assessment and will involve the examination of growth options to accommodate population and employment growth

OUR Vision: To be the best place to raise a child and age successfully.

OUR Mission: To provide high quality cost conscious public services that contribute to a healthy, safe and prosperous community, in a sustainable manner.

OUR Culture: Collective Ownership, Steadfast Integrity, Courageous Change, Sensational Service, Engaged Empowered Employees.

**SUBJECT: GRIDS 2 and Municipal Comprehensive Review – Work Plan Update
(City Wide) (PED17010(d)) – Page 3 of 5**

and, ultimately, the identification of a preferred growth option. Phase 4 will be the update to the UHOP and RHOP to implement the MCR and the new Provincial Plans. The updated work plan timeline is attached as Appendix “A” to Report PED17010(d), and highlighted below:

2019:	
October 21	Council workshop (Special GIC): <i>GRIDS background, Intensification and Density targets, Employment review, and Land Needs scenarios</i>
November 6	General Issues Committee: <i>Request to commence consultation on Employment Land Review, Intensification and Density targets</i>
Mid-November	Public Consultation: <i>Employment Land Review, Intensification and Density Targets, Update on MTSA Planning and Urban Structure review</i>
2020:	
February	General Issues Committee: <i>Approval of Employment Land Review, Approval of inputs into Land Needs Assessment, Approval of alternative targets if required, Receive Land Needs Assessment, Define evaluation framework</i>
February	Release of final Land Needs Assessment and Call for Requests: <i>Public release of Land Needs Assessment and evaluation framework for consideration of growth options, Call for requests for consideration of urban boundary expansion</i>
May	General Issues Committee: <i>Evaluation results and preferred growth option, request to commence consultation</i>
May	Public Consultation: <i>Results of evaluation and Preferred growth option</i>
September / October	General Issues Committee: <i>Final preferred growth option</i>

The Council workshop planned for October 21 will be structured as an information session for staff to provide members of Council with important context information related to the first GRIDS process and the identification of Elfrida as the City’s preferred growth area to 2031 (i.e. “*how we got to where we are today*”); and information on the studies and analysis being completed for GRIDS 2 (i.e. “*where are we going*”). This will

OUR Vision: To be the best place to raise a child and age successfully.

OUR Mission: To provide high quality cost conscious public services that contribute to a healthy, safe and prosperous community, in a sustainable manner.

OUR Culture: Collective Ownership, Steadfast Integrity, Courageous Change, Sensational Service, Engaged Empowered Employees.

**SUBJECT: GRIDS 2 and Municipal Comprehensive Review – Work Plan Update
(City Wide) (PED17010(d)) – Page 4 of 5**

not be a decision making session, and it will be open for members of the public to attend and view if desired.

4.1 Timing Unknowns

The work plan above could be impacted by factors beyond staff's control, including:

- Additional future provincial planning changes, which could include changes to the Provincial Policy Statement (PPS), additional Growth Plan changes, and / or changes to the Provincial Land Needs Assessment Methodology. The timing of these future changes are unknown, but as changes are announced, staff will be required to review and react to the new directions.
- Submission of privately-initiated requests to expand the urban boundary and /or convert employment land to a non-employment use. As previously noted, the new Growth Plan has introduced policies which allow for privately initiated applications for urban boundary expansion and employment land conversion, subject to criteria, in advance of the MCR. Council has adopted a strategy for responding to these applications, including an increased application fee, peer review agreement, and list of required studies to accompany an application (staff report PED19146). Should this type of application be received by the City, staff will be required to circulate, review and respond to this application within the *Planning Act* 120 day timeframe. This will require staff resources from multiple divisions to re-allocate their work priorities away from the GRIDS 2 / MCR project to instead focus on individual applications.
- The ongoing RHOP and UHOP appeals which are currently before the Local Planning Appeal Tribunal (LPAT) could also have an impact on timing. At an October motion hearing, evidence was heard as to whether the RHOP and UHOP appeals, which date to 2009 and 2011 respectively, will be heard and disposed of in accordance with the 2006 Growth Plan or the 2017 Growth Plan. The 2017 Growth Plan has now been replaced by the 2019 Growth Plan. Depending on the decision coming out of this motion hearing, the work plan for GRIDS 2 and the MCR could be delayed pending the outcome of the appeals.

4.2 Impact on Elfrida Growth Area Study

Information from the Land Needs Assessment (LNA) and the identification of the preferred growth option to 2041 is required prior to commencing the next phase of the Study. Based on the updated MCR work plan attached as Appendix "A" to Report PED17010(d), the results of the LNA are tentatively expected early 2020, with the evaluation and identification of the preferred growth option completed by mid-2020 (subject to the timing unknowns noted above).

OUR Vision: To be the best place to raise a child and age successfully.

OUR Mission: To provide high quality cost conscious public services that contribute to a healthy, safe and prosperous community, in a sustainable manner.

OUR Culture: Collective Ownership, Steadfast Integrity, Courageous Change, Sensational Service, Engaged Empowered Employees.

**SUBJECT: GRIDS 2 and Municipal Comprehensive Review – Work Plan Update
(City Wide) (PED17010(d)) – Page 5 of 5**

APPENDICES AND SCHEDULES ATTACHED

Appendix “A” – Work Plan

HT:mo

**November –
Open House and
stakeholder workshop,
Round 2**

- LNA Inputs / targets (RI, DGA, MTSA, Employment)
- Employment Land Review
- RI Supply Update
- Urban Structure update

**February –
Public Release of LNA
and Call for Requests:**

- LNA results
- Evaluation Framework
- Requests for consideration

**May –
Open House and
Stakeholder
Workshop, Round 3**

- Preferred Growth Option

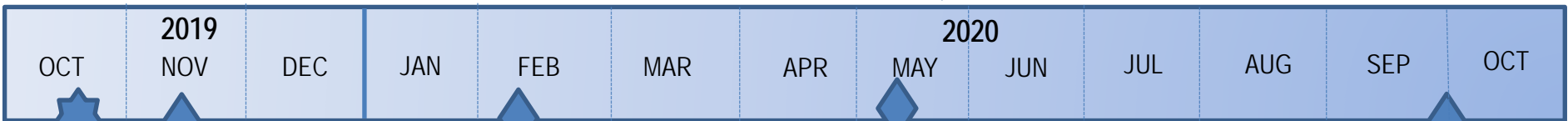

**October 21:
Council
workshop –
GRIDS
background,
targets, and
LNA scenarios**

**November 6:
GIC –
commence
consultation
on targets and
employment
review**

**February: GIC –
Approval of
employment review,
inputs into the LNA,
receive final LNA
define evaluation
framework**

**May: GIC –
Evaluation results
and preferred
growth option,
commence
consultation**

**September /
October: GIC -
approval of
preferred growth
option**

To
2021

**Phase 2:
Technical Studies**

- RI Strategy
- Urban Structure Review
- Housing Strategy
- Employment Conversion
- MTSA Planning
- Greenfield Analysis
- LNA

**Phase 3: Analysis of Growth
Options**

- LNA Results
- Evaluation Framework
- Growth Options evaluation
- Identify Preferred Option
- Master Plan Updates

**Phase 4:
Official
Plan
Review
(ongoing
to 2021)**



CITY OF HAMILTON
PLANNING AND ECONOMIC DEVELOPMENT DEPARTMENT
Tourism and Culture Division

TO:	Mayor and Members General Issues Committee
COMMITTEE DATE:	August 12, 2019
SUBJECT/REPORT NO:	Memorandum of Understanding City of Hamilton and Hamilton 100 Commonwealth Games Bid Corporation (PED19108(a)) (City Wide) (Outstanding Business List Item)
WARD(S) AFFECTED:	City Wide
PREPARED BY:	Carrie Brooks-Joiner (905) 546-2424 Ext. 3967
SUBMITTED BY:	Carrie Brooks-Joiner Acting Director, Tourism and Culture Planning and Economic Development Department
SIGNATURE:	

RECOMMENDATION(S)

That the General Manager of Finance and Corporate Services be granted the authority to sign, on behalf of the City of Hamilton, a Memorandum of Understanding with Hamilton100 Commonwealth Games Bid Corporation, attached as Appendix "A" to Report PED19108(a), and any other ancillary documents or agreements, each in a form satisfactory to the City Solicitor.

EXECUTIVE SUMMARY

Hamilton100 Commonwealth Games Bid Corporation (Hamilton 100), a local community consortium voluntarily stepped forward to lead and finance the development of a proposal to host the 2030 Commonwealth Games in Canada. In recognition that City of Hamilton staff assistance will be required to compile the information necessary to complete some of the required documentation, it is desirable to clarify roles and responsibilities for City of Hamilton and Hamilton100. At the June 12, 2019 Council meeting (Report PED19108) staff were directed follows:

- (a) That the General Manager of Planning and Economic Development be authorized and directed to develop a Memorandum of Understanding with Hamilton 100

OUR Vision: To be the best place to raise a child and age successfully.

OUR Mission: To provide high quality cost conscious public services that contribute to a healthy, safe and prosperous community, in a sustainable manner.

OUR Culture: Collective Ownership, Steadfast Integrity, Courageous Change, Sensational Service, Engaged Empowered Employees.

SUBJECT: Memorandum of Understanding with Hamilton 100 Commonwealth Games Bid Corporation (PED19108(a) (City Wide) - Page 2 of 4

confirming their commitment to lead the 2030 Commonwealth Games Hosting Proposal (Part 1) detailing their financial commitment, the scope of work they are assuming, and resources required from the City of Hamilton to complete the work, in a form satisfactory to the City Solicitor, and report back to the General Issues Committee.

The consortium recently incorporated as Hamilton100 Commonwealth Games Bid Corporation (Hamilton100) and is therefore able to enter into a Memorandum of Understanding (MOU) with the City of Hamilton. The MOU is attached as Appendix “A” to Report PED19108(a).

Alternatives for Consideration – Not Applicable

FINANCIAL – STAFFING – LEGAL IMPLICATIONS

Financial: N/A

Staffing: N/A

Legal: MOU drafted by Legal Services is attached as Appendix “A” to Report PED19108(a).

HISTORICAL BACKGROUND

The Commonwealth Games are an international multi-sport event involving athletes from the Commonwealth of Nations. The event was first held in Hamilton in 1930 and has taken place every four years since.

At the March 20, 2019 General Issues Committee, Hamilton100 made a delegation with the goal to “bring the 2030 Commonwealth Games back to Hamilton, the founding city and host of the first games”. The group offered to lead and wholly fund the development of a bid on behalf of Hamilton. At the meeting, staff were directed to report back to GIC “with the outline of the games, the bidding process, risks and rewards, potential venues and facilities that the City of Hamilton would require to host the 2030 Commonwealth Games”.

Staff reported to GIC on June 5, 2019 and the staff direction has resulted in this report.

POLICY IMPLICATIONS AND LEGISLATED REQUIREMENTS

N/A

SUBJECT: Memorandum of Understanding with Hamilton 100 Commonwealth Games Bid Corporation (PED19108(a) (City Wide) - Page 3 of 4

RELEVANT CONSULTATION

Deputy City Solicitor, Legal and Risk Management Services, Corporate Services

Executive, Hamilton100 Commonwealth Games Bid Corporation

ANALYSIS AND RATIONALE FOR RECOMMENDATION(S)

This MOU outlines the roles and responsibilities for City and Hamilton and Hamilton100 with respect to the development and financing of the Commonwealth Games 2030 Hosting Proposal 1.

The MOU addresses:

- I. Primary Objectives and Timelines
- II. Areas of Collaboration
- III. Due Diligence
- IV. Communications
- V. Principal Contacts
- VI. Effective Dates
- VII. No Joint Venture

ALTERNATIVES FOR CONSIDERATION

N/A

ALIGNMENT TO THE 2016 – 2025 STRATEGIC PLAN

Community Engagement and Participation

Hamilton has an open, transparent and accessible approach to City government that engages with and empowers all citizens to be involved in their community.

Economic Prosperity and Growth

Hamilton has a prosperous and diverse local economy where people have opportunities to grow and develop.

Healthy and Safe Communities

Hamilton is a safe and supportive City where people are active, healthy, and have a high quality of life.

SUBJECT: Memorandum of Understanding with Hamilton 100 Commonwealth Games Bid Corporation (PED19108(a) (City Wide) - Page 4 of 4

Built Environment and Infrastructure

Hamilton is supported by state of the art infrastructure, transportation options, buildings and public spaces that create a dynamic City.

Culture and Diversity

Hamilton is a thriving, vibrant place for arts, culture, and heritage where diversity and inclusivity are embraced and celebrated.

Our People and Performance

Hamiltonians have a high level of trust and confidence in their City government.

APPENDICES AND SCHEDULES ATTACHED

Appendix "A" to Report PED19108(a) - Memorandum of Understanding City of Hamilton and Hamilton100 Commonwealth Games Bid Corporation

CBJ:ro

MEMORANDUM OF UNDERSTANDING (the "MOU")

BETWEEN

CITY OF HAMILTON (the "City")

-AND-

HAMILTON100 COMMONWEALTH GAMES BID CORPORATION ("Hamilton100")

Each a "**Party**" and collectively the "**Parties**"

WHEREAS:

- a. the City is a municipal corporation with its offices located in Hamilton, Ontario;
- b. Hamilton100 is a corporation incorporated under the *Canada Not-for-profit Corporations Act* and was created for the purpose of organizing, facilitating, preparing, financing and submitting a bid to secure the rights to host the 2030 Commonwealth Games in Hamilton, Ontario (the "**Bid**");
- c. the City, as the hosting municipality, is required to sanction the Bid;
- d. the City has agreed to support Hamilton100's proposal to submit the first phase of the Bid ("**Phase 1**") on the express condition that the City shall not assume any liability of any kind, be it legal, financial or otherwise, and Hamilton100 has agreed to that condition;
- e. on June 12, 2019, Hamilton City Council authorized and directed staff to negotiate a draft MOU with Hamilton100 for Council's review and consideration; and
- f. on August 16, 2019, Hamilton City Council approved this MOU.

NOW THEREFORE, in consideration of the foregoing, the covenants contained herein, and other good and valuable consideration, the receipt and sufficiency of which are hereby acknowledged by both Parties, the City and the Builder agree as follows:

I. PRIMARY OBJECTIVES AND TIMELINES

The primary objective of this MOU is to permit Hamilton100 to prepare, organize, facilitate, coordinate and finance in its entirety, and to the City's satisfaction, Phase 1 of the Bid for the 2030 Commonwealth Games. To the end, Hamilton100 shall submit:

- a. a draft Phase 1 proposal to the City by August 6, 2019;
- b. a final Phase 1 proposal to the City for consideration by City Council at its General Issues Committee meeting scheduled for November 6, 2019; and
- c. its final Phase 1 proposal to Commonwealth Games Canada by November 22, 2019 after obtaining the approval of City Council.

The Parties further agree that the Bid, including Phase 1, shall:

- a. celebrate Hamilton's legacy with the Commonwealth Games and, particularly, the 100th anniversary of the initial British Empire Games held in Hamilton in 1930;
- b. align with the City's vision ("To be the best place to raise a child and age successfully"), plans, values and priorities including, in particular, its:

- i. commitment to equality, diversity, accessibility, tolerance, Green/climate change initiatives, social procurement and social housing; and
 - ii. Strategic Plan and Recreational Indoor/Outdoor Master Plan;
- c. enhance Hamilton's reputation, identity and civic pride;
 - d. maximize investment in Hamilton wherever possible;
 - e. utilize existing facilities in the City of Hamilton where appropriate;
 - f. engage in public/private partnerships where appropriate; and
 - g. identify and create long-term legacy projects that will facilitate serving the needs of the Hamilton community.

II. AREAS OF COLLABORATION

It is expressly agreed by the Parties that the City shall assume no liability for any obligations arising out of the preparation, finalization and submission of the Phase Bid. However, the City does agree to provide advice and expertise in various areas including affordable and social housing, community health and wellness, tourism, economic development, sport development, recreation, security, hospitality, and special events. It is further agreed that the City shall have the unfettered right and discretion to designate a person or persons to serve as the City's representative(s) on the Hamilton100 Committee, with the express understanding that any designated City representative shall assume absolutely no liability for any obligation undertaken by Hamilton100.

III. DUE DILIGENCE

At the City's request, Hamilton100 shall provide copies of any relevant documents to ensure that Hamilton100 meets appropriate standards of capacity, competence and financial accountability. These documents include, but are not limited to, the following: a certificate of good standing; a list of the names of all of its directors, committee members and principal officers; and copies of Hamilton100's by-laws and articles of incorporation. Hamilton100 agrees to notify the City immediately of any change in Hamilton100's status or operations, or if any official, judicial, legislative, or administrative proceeding is commenced against Hamilton100.

IV. COMMUNICATIONS

On City Council's approval of Hamilton100's Phase 1 proposal, Hamilton100 may establish a social media and public communications presence in support of the Bid including a website and participation in various platforms such as Facebook, Twitter and Instagram. The City shall have ongoing access to the social media and public communications information posted by Hamilton100 which Hamilton100 will revise as directed by the City.

V. PRINCIPAL CONTACTS

The Principal Contacts for each Party are:

City of Hamilton:

Mike Zegarac
General Manager Finance and Corporate Services
71 Main St W 1st Floor
Hamilton, ON L8P 4Y5
(905) 546-2424 x6150

Hamilton100 Commonwealth Games Bid Corporation:

PJ Mercanti
President
Suite 300 – 77 James Street North
Hamilton, ON L8K 2K3
(905) 383-4100

Each Party shall immediately advise the other Party in writing of any change it in the contact information for its Principal Contacts.

VI. EFFECTIVE DATES

This MOU shall take effect on August 1, 2019 and shall remain in effect until consideration by City Council of the draft Phase 1 Hosting Proposal, at which time City Council will either authorize, or deny authorization, to Hamilton100 to submit its Phase 1 Bid to the Commonwealth Games Canada by its November 22, 2019 deadline.

In the event the City does authorize Hamilton100 to submit the Phase 1 Bid to Commonwealth Games Canada, the Parties undertake to then enter into good-faith discussions and negotiations regarding the terms of a subsequent MOU to govern preparation of phase 2 of the Bid ("**Phase 2**") the submission of which will likely be required in 2020. It is expressly understood and agreed by the Parties that the City will have the unfettered and absolute discretion to authorize submission of Phase 2.

It is agreed and understood by the Parties that the City has the absolute right and discretion to withdraw its permission to allow Hamilton100 to proceed with the Bid at any time and for any reason.

VII. NO JOINT VENTURE

The Parties agree that, notwithstanding this MOU, they are not entering into a partnership, joint venture or other such business arrangement, nor is the intent of the Parties to enter into a commercial undertaking for monetary gain.

EXECUTION PAGE FOLLOWS

IN WITNESS WHEREOF this Agreement has been executed by the authorized representative of each Party.

City of Hamilton

Hamilton100 Commonwealth Bid Corporation

Mike Zegarac
General Manager, Finance & Corporate Services

PJ Mercanti
President

Date

Date



CITY OF HAMILTON
PLANNING AND ECONOMIC DEVELOPMENT DEPARTMENT
Economic Development Division

TO:	Mayor and Members General Issues Committee
COMMITTEE DATE:	August 12, 2019
SUBJECT/REPORT NO:	Environmental Remediation and Site Enhancement (ERASE) Redevelopment Grant Application, 1160 Main Street East, ERG19-01 (PED19153) (Ward 3)
WARD(S) AFFECTED:	Ward 3
PREPARED BY:	Phillip Caldwell (905) 546-2424 Ext. 2359
SUBMITTED BY:	Glen Norton Director, Economic Development Planning and Economic Development Department
SIGNATURE:	

RECOMMENDATION

- (a) That Environmental Remediation and Site Enhancement (ERASE) Redevelopment Grant Application - ERG19-01, submitted by Main Street East Ltd., owner of the property at 1160 Main Street East, for an ERASE Redevelopment Grant not to exceed \$1,391,210, the actual cost of the remediation over a maximum of ten years, be authorized and approved in accordance with the terms and conditions of the ERASE Redevelopment Agreement;
- (b) That the Mayor and City Clerk be authorized and directed to execute the Environmental Remediation and Site Enhancement (ERASE) Redevelopment Agreement together with any ancillary documentation required, to effect Recommendation (a) of Report PED19153, in a form satisfactory to the City Solicitor;
- (c) That the General Manager of the Planning and Economic Development Department be authorized to approve and execute any grant amending agreements, together with any ancillary amending documentation, if required, provided that the terms and conditions of the Environmental Remediation and Site Enhancement (ERASE) Redevelopment Grant, as approved by City Council, are maintained.

OUR Vision: To be the best place to raise a child and age successfully.

OUR Mission: To provide high quality cost conscious public services that contribute to a healthy, safe and prosperous community, in a sustainable manner.

OUR Culture: Collective Ownership, Steadfast Integrity, Courageous Change, Sensational Service, Engaged Empowered Employees.

**SUBJECT: Environmental Remediation and Site Enhancement (ERASE)
Redevelopment Grant Application, 1160 Main Street East, ERG19-01
(PED19153) (Ward 3) - Page 2 of 7**

EXECUTIVE SUMMARY

An Environmental Remediation and Site Enhancement (ERASE) Redevelopment Grant Application was submitted on March 12, 2019 by Main Street East Ltd., the owner of the property located at 1160 Main Street East, Hamilton (“the site”). A Phase One Environmental Site Assessment (ESA), was undertaken in 2018 to determine if there were potential sources of contamination on the site that could result in an Area of Potential Environmental Concern (APEC).

The site is approximately 0.16 ha (0.39 ac) in size and fronts on to the south-side of Main Street East. The closest major intersection is Main Street East and Ottawa Street located approximately 100 metres east. The site is bounded by residential buildings to the east, south and west and by a mixed-use commercial/residential building, as well as Memorial Elementary School, to the north. The site consists of a partially vacant two-storey commercial building with associated surface parking.

The Phase One ESA revealed that historical on-site activities had the potential to be of environmental concern stemming from the sites historical use as a vehicle sales and repair business as well as records indicating the potential for former Underground Storage Tanks (UST) and imported fill of an unknown quality on the site.

A subsequent Phase Two ESA was completed in 2018 informed by the collection of soil samples and groundwater monitoring on the property. The results confirmed evidence of Areas of Potential Environmental Concern (APEC) related to sources of electrical conductivity (EC), select metals, petroleum hydrocarbons (PHCs) and polycyclic aromatic hydrocarbon (PAHs).

The grant application is for \$1,391,210 in eligible costs associated with environmental site remediation and additional study costs. The proposed redevelopment of the site, for which Site Plan approval has been granted, is for a seven-storey mixed use building consisting of 75 residential rental units and ground floor retail/commercial floor space.

Project construction costs are estimated at approximately \$20 M. It is estimated that the proposed redevelopment will increase the property assessment from the pre-development value of \$635,500 (CT - Commercial) to approximately \$11,750,000 (NT – New Multi-Residential and XT – Commercial, New Construction). This will increase total annual property taxes generated by this property from \$19,899 to \$155,213, an increase of approximately \$135,314. The municipal portion of this increase is \$117,645 of which 80% or approximately \$94,116 would be paid to the owner in the form of an annual grant over a maximum of ten years or up to an amount not to exceed total estimated eligible costs for an ERASE Redevelopment Grant of \$1,391,210.

**SUBJECT: Environmental Remediation and Site Enhancement (ERASE)
Redevelopment Grant Application, 1160 Main Street East, ERG19-01
(PED19153) (Ward 3) - Page 3 of 7**



Existing Conditions – 1160 Main Street East, Hamilton



Planned Redevelopment – 1160 Main Street East, Hamilton

OUR Vision: To be the best place to raise a child and age successfully.
OUR Mission: To provide high quality cost conscious public services that contribute to a healthy, safe and prosperous community, in a sustainable manner.
OUR Culture: Collective Ownership, Steadfast Integrity, Courageous Change, Sensational Service, Engaged Empowered Employees.

SUBJECT: Environmental Remediation and Site Enhancement (ERASE) Redevelopment Grant Application, 1160 Main Street East, ERG19-01 (PED19153) (Ward 3) - Page 4 of 7

Alternatives for Consideration – See Page 7

FINANCIAL – STAFFING – LEGAL IMPLICATIONS

Financial: As per the ERASE Redevelopment Grant Program (RGP), the City will provide the applicant with a grant equivalent to 80% of the increase in municipal taxes up to the total eligible cost figure of \$1,391,210. Based on an annual grant amount of \$94,116 the annual grant payments will conclude in year ten with an estimated total grant of \$941,162. The City will realize the full tax increase after year ten.

The City will retain 20% of the municipal tax increment estimated at \$23,529 a year for ten years. These monies will be deposited into the Brownfield Pilot Project Account No. 3620155102 - to be used by the City for its Municipal Acquisition and Partnership Program. This Program, as approved in the ERASE Community Improvement Plan (CIP), involves the City acquiring key Brownfield sites, cleaning up and redeveloping property it already owns, or participating in public/private partnerships to redevelop Brownfield properties.

Staffing: Applications and loan/grant payments under the ERASE RGP are processed by the Economic Development Division and Taxation Division. There are no additional staffing requirements.

Legal: The provision of the ERASE RGP is authorized in the ERASE CIP which was adopted and approved in 2001 and the expansion of the original plan in 2005, 2010 and 2018 under Section 28 of the *Planning Act*. The ERASE Redevelopment Agreement will specify the obligations of the City and the applicant and will be prepared in a form satisfactory to the City Solicitor.

HISTORICAL BACKGROUND

1160 Main Street East (“the site”) is located in a commercial/residential area fronting onto Main Street East between Balmoral Avenue South and Grosvenor Avenue South. The closest major intersection is Main Street East and Ottawa Street approximately 100 metres east. The site is rectangular in shape and approximately 0.16 ha (0.39 ac) in size. The site is bounded by residential buildings to the east, south and west and by a mixed-use commercial/residential building and Memorial Elementary School to the north. The site currently consists of a two-storey commercial building with associated surface parking. The building has had numerous expansions and additions since the 1950’s and has housed a variety of commercial uses. The building currently contains a video rental

**SUBJECT: Environmental Remediation and Site Enhancement (ERASE)
Redevelopment Grant Application, 1160 Main Street East, ERG19-01
(PED19153) (Ward 3) - Page 5 of 7**

store and one vacant unit. Historically the site has been occupied by a vehicle sales and repair business and residential uses.

A Phase One Environmental Site Assessment (ESA) was undertaken in 2018, the results of which identified three potential on-site and six off-site sources of potential environmental concern. The off-site sources were interpreted to be of low risk to the site given their distance and the prevailing direction of groundwater flow in this area. Nonetheless the off-site sources were considered within the scope of the subsequent Phase Two ESA. The three on-site sources of potential environmental concern were:

- The site's former use as a vehicle sales and repair business and the associated potential for solvents and hazardous waste generation;
- The importation of fill materials to the site of unknown quality; and,
- The potential use of Underground Storage Tanks (UTC) for heating oils.

An initial Phase Two ESA was undertaken in 2018 and included the drilling of six boreholes, three of which were completed as groundwater monitoring wells. The results confirmed the presence of contamination and identified the Contaminants of Concern (COC) as petroleum hydrocarbons (PHCs) likely associated with the UTC, electrical conductivity (EC), select metals and polycyclic aromatic hydrocarbons (PAHs). The COC's identified exceeded the Ministry of Environment, Parks and Conservation's ("the Ministry") Table 7 Site Condition Standards (SCS) for residential/parkland/institutional land use in shallow groundwater conditions.

Supplemental soil and groundwater sampling was completed in 2018 and 2019 to further delineate the vertical and horizontal extents of the contamination to inform the development of a supplemental Phase II ESA for the purposes of a future Record of Site Condition (RSC) filing in accordance with the Ministry's Ontario Regulation. 153/04. The sites change of use from commercial to residential requires an RSC to be filed with the Ministry upon completion of the remediation.

A Remedial Action Plan (RAP) was prepared in 2018 to develop a plan for the remediation of the site. The RAP was further updated in 2019 based on supplemental testing and identified the need for the removal of between 4,000 to 7,000 metric tonnes of contaminated soil. In addition, the RAP anticipated the presence of contaminated groundwater in the vicinity of the UTC that will be required to be removed in a volume of between 50 and 200 m³. The remediation plan also includes the removal of the existing UTCs.

**SUBJECT: Environmental Remediation and Site Enhancement (ERASE)
Redevelopment Grant Application, 1160 Main Street East, ERG19-01
(PED19153) (Ward 3) - Page 6 of 7**

POLICY IMPLICATIONS AND LEGISLATED REQUIREMENTS

Urban Hamilton Official Plan

The site is designated as a Primary Corridor on Schedule “E” – Urban Structure and as “Mixed Use - Medium Density” on Schedule “E-1” – Urban Land Use Designations of the Urban Hamilton Official Plan. This designation permits a full range of commercial uses, entertainment, recreational and residential uses at a medium density, to which the proposed development complies.

Hamilton Zoning By-law No. 05-200

The subject property is zoned “TOC1” Transit Oriented Corridor Mixed Use Medium Density. The proposed use of the site is permitted.

Site Plan Control Application

The site is subject to Site Plan Control. At the time of writing of this Report, the proposed development has received conditional Site Plan approval.

RELEVANT CONSULTATION

Staff from the Taxation Division, Corporate Services Department and Legal Services Division, Corporate Services Department, were consulted and the advice received is incorporated into this Report.

ANALYSIS AND RATIONALE FOR RECOMMENDATION(S)

Grant Level:		80%
Total Eligible Costs (Maximum):	\$	1,391,210
Pre-project CVA: (CT - Commercial)	\$	635,500 Year: 2019
Municipal Levy:	\$	13,349
Education Levy:	\$	<u>6,550</u>
Pre-project Property Taxes	\$	19,899
*Estimated Post-project CVA: (NT – New Multi-Residential/ XT – Commercial, New Construction)	\$	11,750,000
Total Estimated Ten-Year Grant (Maximum):	\$	941,162

**SUBJECT: Environmental Remediation and Site Enhancement (ERASE)
Redevelopment Grant Application, 1160 Main Street East, ERG19-01
(PED19153) (Ward 3) - Page 7 of 7**

**Estimated Municipal Levy:	\$	130,994
**Estimated Education Levy:	\$	<u>24,218</u>
**Estimated Post-project Property Taxes:	\$	155,212

Note: All dollar figures are rounded to the nearest dollar.

**The actual roll number(s), assessed value(s), tax classification(s) and value partitioning (where applicable) are to be determined by the Municipal Property Assessment Corporation (MPAC).*

***2019 tax rates have been used for calculation of the estimated post-development property taxes.*

ALTERNATIVES FOR CONSIDERATION

The grant application meets the eligibility criteria and requirements of the program. In the event the project is not considered for the program, the application should be referred back to staff for further information on possible financial or legal implications.

ALIGNMENT TO THE 2016 – 2025 STRATEGIC PLAN

Economic Prosperity and Growth

Hamilton has a prosperous and diverse local economy where people have opportunities to grow and develop.

Healthy and Safe Communities

Hamilton is a safe and supportive City where people are active, healthy, and have a high quality of life.

Our People and Performance

Hamiltonians have a high level of trust and confidence in their City government.

APPENDICES AND SCHEDULES ATTACHED

Appendix “A” – Location Map

PC:dt

Appendix "A" to Report PED19153
Page 1 of 1



Key Map - Ward 3

Location Map



PLANNING AND ECONOMIC DEVELOPMENT DEPARTMENT

File Name/Number:
1160 Main St E

Date:
June 14, 2019

Appendix "A"

Scale:
N.T.S

Planner/Technician:
PC/SN

Subject Property

1160 Main Street East, Hamilton
(Ward 3)



Hamilton

**ADVISORY COMMITTEE FOR PERSONS WITH
DISABILITIES**

Report 19-006

4:00 p.m.

Tuesday, July 9, 2019

Rooms 192 and 193, City Hall

71 Main Street West

Present: S. Aaron, J. Cardno, L. Dingman, A. Frisina, S. Geffros, C. McBride, M. McNeil, T. Murphy, K. Nolan, T. Nolan, and A. Wilson

Absent

with regrets: J. Hawker and A. Mallet

Also Present: Sergeant S. Moore, Hamilton Police Service

**THE ADVISORY COMMITTEE FOR PERSONS WITH
DISABILITIES PRESENTS REPORT 19-006 AND
RESPECTFULLY RECOMMENDS:**

1. Appointment of Chair and Vice-Chair (Item 1)

- (a) That A. Mallett be appointed as Chair of the Advisory Committee for Persons with Disabilities for 2019; and,

- (b) That J. Cardno be appointed as Vice-Chair of the Advisory Committee for Persons with Disabilities for 2019.

2. Establishment of Working Group Memberships (deferred from the June 11, 2019 meeting) (Item 10.1)

- (a) That a Community Safety Working Group be established on a pilot basis for 2019;
- (b) That a Disability Justice and Climate Crisis Working Group be established on a pilot basis for 2019; and,
- (c) That a Built Environment Working Group, Housing Issues Working Group, Outreach Working Group, Transportation Working Group, and Wheelchair and Scooter Safety Working Group be established on a pilot basis for 2019.

FOR INFORMATION:

(a) CHANGES TO THE AGENDA (Item 2)

The Committee Clerk advised of the following changes to the agenda:

1. STAFF PRESENTATIONS

- 9.1. Adaptive Bike Share

2. DISCUSSION ITEMS

- 10.1. Establishment of Working Group Memberships (deferred from the June 11, 2019 meeting)

10.1.f Disability and Environmental Justice
Working Group

10.1.g Community Safety Working Group

10.5. Accessible Pedestrian Signals Video

The agenda for the July 9, 2019 meeting of the Advisory Committee for Persons with Disabilities was approved, as amended.

(b) DECLARATIONS OF INTEREST (Item 3)

There were no declarations of interest.

(c) APPROVAL OF MINUTES (Item 4)

(i) June 11, 2019 (Item 4.1)

The minutes of the June 11, 2019 meeting of the Advisory Committee for Persons with Disabilities, were approved, as presented.

(d) STAFF PRESENTATIONS (Item 9)

(i) Adaptive Bike Share (Added Item 9.1)

Peter Topalovic, Program Manager of Sustainable Mobility Programs and Bike Share, and Chelsea Cox, Hamilton Bikes Share, addressed the Committee respecting an Adaptive Bike Share, with the aid of a presentation.

The presentation, respecting an Adaptive Bike Share, was received.

A copy of the presentation is available on the City's website at www.hamilton.ca or through the Office of the City Clerk.

(e) DISCUSSION ITEMS (Item 10)

The following discussion items were deferred to the August 13, 2019 Advisory Committee for Persons with Disabilities meeting due to time constraints:

- (i) Advisory Committee for Persons with Disabilities Budget (Item 10.2)
- (ii) Appointment of Greater Toronto and Hamilton Area Accessibility Advisory Committee (GTHA AAC) Representative (Item 10.3)
- (iii) Notice of Ministry Training Webinar for Municipal Accessibility Advisory Committees (Item 10.4)
- (iv) Accessible Pedestrian Signals Video (Added Item 10.5)

(f) ADJOURNMENT (Item 15)

There being no further business, the Advisory Committee for Persons with Disabilities was adjourned at 5:58 p.m.

Respectfully submitted,

J. Cardno, Vice-Chair
Advisory Committee for
Persons with Disabilities

Alicia Davenport
Legislative Coordinator
Office of the City Clerk



INFORMATION REPORT

TO:	Mayor and Members General Issues Committee
COMMITTEE DATE:	August 12, 2019
SUBJECT/REPORT NO:	Policies and Procedures for Hate Mitigation (CM19006)
WARD(S) AFFECTED:	City Wide
PREPARED BY:	John Hertel – Director Strategic Partnerships & Communications Jodi Koch – Director Talent and Diversity
SUBMITTED BY:	Mike Zegarac Acting City Manager City Manager Department
SIGNATURE:	

INFORMATION

Recommendation Report “Hate Related Activities on City of Hamilton Properties (LS19031/PW19068) (City Wide)” was presented at the General Issues Committee on July 8, 2019.

Direction was provided to staff to consult with the community for feedback related to the draft policies and procedures presented in the report. Staff will develop the consultation process and engagement schedule and provide a status update to Committee as part of the broader October report.

Subsequently a Governance Model has been established to oversee and execute on the consultation:

1. Leadership for the related activities will be provided by:
 - a. City Manager – Janette Smith
 - b. General Manager Public Works – Dan McKinnon
 - c. Executive Director HR – Lora Fontana
 - d. Director Strategic Partnerships and Communications – John Hertel
2. A Working Team to design and deliver the consultation will consist of:
 - a. HR – Jodi Koch - Director Talent and Diversity

OUR Vision: To be the best place to raise a child and age successfully.

OUR Mission: To provide high quality cost conscious public services that contribute to a healthy, safe and prosperous community, in a sustainable manner.

OUR Culture: Collective Ownership, Steadfast Integrity, Courageous Change, Sensational Service, Engaged Empowered Employees.

**SUBJECT: Hate Related Activities on City of Hamilton Properties (CM19006) -
Page 2 of 2**

- b. Legal Services – Daron Earthy, Solicitor City of Hamilton
- c. Community Initiatives – John Ariyo, Manager
- d. S.E.A.T. – Dawn Walton – Manager Business Support
- e. Communications - Jacqueline Durlov – Communications Officer
- f. Facilities – Jeff Drummond Supervisor Facilities
- g. *Project Management
 - i. *An External Expression of Interest will be issued to secure a contracted Senior Project Manager, with expertise and experience related to this subject matter. The successful candidate will report to John Ariyo on behalf of the Working Team.

Consistent with previous directions, staff will provide an update to General Issues Committee in October 2019.

APPENDICES AND SCHEDULES ATTACHED

NA

Repair Rehabilitation Summary

City of Hamilton

Element Group	Element	Repair/Rehabilitation Required	Priority	Cost	Comments
Sign Supports					
1	BCI: 0.00				<i>Inspected on: 15-May-12</i>
ARL (Upper James Street)					
Diagonal	> Leg	Rehabilitation	Within 1yr	2,500	Repair cracks
Diagonal	> Truss	Rehabilitation	Within 1yr	2,500	Repair cracks
Connection	> Walkway Arm Clamps	Rehabilitation	Within 1yr	10,000	Replace clamps
				Total Repair/Rehabilitation Cost	15,000
				Total Cost of Associated Work	20,500
				Total Cost	<u>35,500</u>
				City of Hamilton Share @ 100%	35,500
10	BCI: 0.00				<i>Inspected on: 22-May-12</i>
ARL (Garth Street)					
Diagonal	> Truss	Rehabilitation	Within 1yr	5,000	Repair cracks
Connection	> Walkway Arm	Rehabilitation	Within 1yr	5,000	Replace clamps
				Total Repair/Rehabilitation Cost	10,000
				Total Cost of Associated Work	20,000
				Total Cost	<u>30,000</u>
				City of Hamilton Share @ 100%	30,000
11	BCI: 0.00				<i>Inspected on: 22-May-12</i>
ARL (Golf Links Rd./Mohawk Rd.)					
Diagonal	> Truss	Rehabilitation	Within 1yr	2,000	Repair crack
Connection	> Sign	Rehabilitation	Within 1yr	2,000	Replace clamp
Diagonal	> Leg	Rehabilitation	Within 1yr	3,000	Repair cracks
Connection	> Walkway Arm	Rehabilitation	Within 1yr	3,000	Replace clamps
				Total Repair/Rehabilitation Cost	10,000
				Total Cost of Associated Work	20,000
				Total Cost	<u>30,000</u>
				City of Hamilton Share @ 100%	30,000

Element Group	Element	Repair/Rehabilitation Required	Priority	Cost	Comments
	BCI: 0.00				<i>Inspected on: 22-May-12</i>
	Tri-Chord (Stone Church Road/Mud Street)				
Coating	> Chords/Main Members	Rehabilitation	Within 1yr	5,000	Patch coating
				Total Repair/Rehabilitation Cost	5,000
				Total Cost of Associated Work	14,000
				Total Cost	<u>19,000</u>
				City of Hamilton Share @ 100%	19,000
13	BCI: 0.00				<i>Inspected on: 22-May-12</i>
	Tri-Chord (Mud Street / Stone Church Road)				
Connection	> Leg	Rehabilitation	Within 1yr	5,000	Reposition pad
				Total Repair/Rehabilitation Cost	5,000
				Total Cost of Associated Work	14,000
				Total Cost	<u>19,000</u>
				City of Hamilton Share @ 100%	19,000
15	BCI: 0.00				<i>Inspected on: 23-May-12</i>
	Tri-Chord (King Street)				
Connection	> Leg	Rehabilitation	Within 1yr	5,000	Replace bolts
				Total Repair/Rehabilitation Cost	5,000
				Total Cost of Associated Work	14,000
				Total Cost	<u>19,000</u>
				City of Hamilton Share @ 100%	19,000
16	BCI: 0.00				<i>Inspected on: 23-May-12</i>
	Tri-Chord (Stone Church Road/Mud Street)				
Connection	> Base	Rehabilitation	Within 1yr	2,500	Tighten bolts
Connection	> Leg	Rehabilitation	Within 1yr	2,500	Replace bolts
				Total Repair/Rehabilitation Cost	5,000
				Total Cost of Associated Work	14,000
				Total Cost	<u>19,000</u>
				City of Hamilton Share @ 100%	19,000

Element Group	Element	Repair/Rehabilitation Required	Priority	Cost	Comments
18	BCI: 0.00				<i>Inspected on: 25-May-12</i>
Tri-Chord (King Street Exit)					
Connection	> Base	Rehabilitation	Within 1yr	5,000	Replace lock nut
				Total Repair/Rehabilitation Cost	5,000
				Total Cost of Associated Work	14,000
				Total Cost	<u>19,000</u>
				City of Hamilton Share @ 100%	19,000
19	BCI: 0.00				<i>Inspected on: 25-May-12</i>
Tri-Chord (Greenhill Avenue)					
Connection	> Base	Rehabilitation	Within 1yr	5,000	Tighten bolts and replace missing lock nut
				Total Repair/Rehabilitation Cost	5,000
				Total Cost of Associated Work	14,000
				Total Cost	<u>19,000</u>
				City of Hamilton Share @ 100%	19,000
2	BCI: 0.00				<i>Inspected on: 15-May-12</i>
ARL (Upper Wentworth Street)					
Connection	> Sign Clamps	Rehabilitation	Within 1yr	7,000	Replace clamps
Connection	> Walkway Arm Clamps	Rehabilitation	Within 1yr	2,000	Replace clamps
Diagonal	> Truss	Rehabilitation	Within 1yr	5,000	Repair cracks
Connection	> Base	Rehabilitation	Within 1yr	1,000	Tighten bolts
				Total Repair/Rehabilitation Cost	15,000
				Total Cost of Associated Work	15,000
				Total Cost	<u>30,000</u>
				City of Hamilton Share @ 100%	30,000
23	BCI: 0.00				<i>Inspected on: 28-May-12</i>
Cantilever (Rousseaux Street Exit)					
Sign Foundatio	> Bearing Surface	Rehabilitation	Within 1yr	5,000	Patch concrete
				Total Repair/Rehabilitation Cost	5,000
				Total Cost of Associated Work	14,000
				Total Cost	<u>19,000</u>
				City of Hamilton Share @ 100%	19,000

Element Group	Element	Repair/Rehabilitation Required	Priority	Cost	Comments
26	BCI: 0.00				<i>Inspected on: 29-May-12</i>
	Tri-Chord (Barton Street)				
Connection	> Base	Rehabilitation	Within 1yr	5,000	Replace missing nut
		Total Repair/Rehabilitation Cost		5,000	
		Total Cost of Associated Work		14,000	
		Total Cost		<u>19,000</u>	
		City of Hamilton Share @ 100%		19,000	
3	BCI: 0.00				<i>Inspected on: 15-May-12</i>
	ARL (Upper James Street Exit)				
Connection	> Sign	Rehabilitation	Within 1yr	1,000	Replace clamp
Connection	> Walkway Arm	Rehabilitation	Within 1yr	4,000	Replace clamps
		Total Repair/Rehabilitation Cost		5,000	
		Total Cost of Associated Work		14,000	
		Total Cost		<u>19,000</u>	
		City of Hamilton Share @ 100%		19,000	
30	BCI: 0.00				<i>Inspected on: 29-May-12</i>
	Tri-Chord (Barton Street) Exit				
Connection	> In Line Chord	Rehabilitation	Within 1yr	5,000	Replace bolts
		Total Repair/Rehabilitation Cost		5,000	
		Total Cost of Associated Work		14,000	
		Total Cost		<u>19,000</u>	
		City of Hamilton Share @ 100%		19,000	
31	BCI: 0.00				<i>Inspected on: 30-May-12</i>
	Tri-Chord (Queenston Road) Exit				
Connection	> Base	Rehabilitation	Within 1yr	5,000	Tighten bolts
		Total Repair/Rehabilitation Cost		5,000	
		Total Cost of Associated Work		14,000	
		Total Cost		<u>19,000</u>	
		City of Hamilton Share @ 100%		19,000	

Element Group	Element	Repair/Rehabilitation Required	Priority	Cost	Comments
36	BCI: 0.00				<i>Inspected on: 31-May-12</i>
ATL (Parkdale Ave/Strathearne Ave/Local Access)					
Diagonal	> Truss	Rehabilitation	Now	10,000	Repair welds
Diagonal	> Leg	Rehabilitation	Now	5,000	Repair welds
Chord/Main Me	> Leg	Rehabilitation	Now	0	Cost covered in chord/main member, base plate
Diagonal	> Corner Arc	Rehabilitation	Now	5,000	Repair welds
Chord/Main Me	> Base Plate	Rehabilitation	Now	5,000	Replace base plate
Total Repair/Rehabilitation Cost				25,000	
Total Cost of Associated Work				40,000	
Total Cost				<u>65,000</u>	
City of Hamilton Share @ 100%				65,000	
37	BCI: 0.00				<i>Inspected on: 31-May-12</i>
ATL WBL (Kenilworth Ave/Woodland Ave)					
Diagonal	> Leg	Rehabilitation	Within 1yr	5,000	Repair cracked and broken welds
Diagonal	> Corner Arc	Rehabilitation	Within 1yr	4,000	Repair cracked and broken welds
Diagonal	> Truss	Rehabilitation	Within 1yr	11,000	Repair cracked and broken welds
Total Repair/Rehabilitation Cost				20,000	
Total Cost of Associated Work				10,000	
Total Cost				<u>30,000</u>	
City of Hamilton Share @ 100%				30,000	
4	BCI: 0.00				<i>Inspected on: 15-May-12</i>
ARL (Garth Street)					
Diagonal	> Leg	Rehabilitation	Within 1yr	5,000	Repair cracks
Total Repair/Rehabilitation Cost				5,000	
Total Cost of Associated Work				14,000	
Total Cost				<u>19,000</u>	
City of Hamilton Share @ 100%				19,000	

Element Group	Element	Repair/Rehabilitation Required	Priority	Cost	Comments
42	BCI: 0.00				<i>Inspected on: 01-Jun-12</i>
Cantilever (Kenilworth Ave. Exit)					
Connection	> Sign	Rehabilitation	Within 1yr	5,000	Tighten bolts and replace missing washers
				Total Repair/Rehabilitation Cost	5,000
				Total Cost of Associated Work	14,000
				Total Cost	<u>19,000</u>
				City of Hamilton Share @ 100%	19,000
43	BCI: 0.00				<i>Inspected on: 01-Jun-12</i>
Cantilever (Through Traffic Exit)					
Connection	> Leg	Rehabilitation	Within 1yr	2,500	Tighten bolts
Connection	> Sign	Rehabilitation	Within 1yr	2,500	Replace bolts
Coating	> Chords/Main Members	Rehabilitation	Within 1yr	5,000	Re-coat members
Coating	> Connection	Rehabilitation	Within 1yr	0	Cost covered under coating, chords/main members
				Total Repair/Rehabilitation Cost	10,000
				Total Cost of Associated Work	20,000
				Total Cost	<u>30,000</u>
				City of Hamilton Share @ 100%	30,000
5	BCI: 0.00				<i>Inspected on: 16-May-12</i>
ARL (Upper Gage Avenue)					
Connection	> Walkway Arm	Rehabilitation	Within 1yr	3,000	Replace clamps
Diagonal	> Truss	Rehabilitation	Within 1yr	2,500	Repair cracks
Diagonal	> Leg	Rehabilitation	Within 1yr	2,500	Repair cracks
Connection	> Sign	Rehabilitation	Within 1yr	1,000	Replace clamps
Connection	> Base	Rehabilitation	Within 1yr	1,000	Tighten bolts
				Total Repair/Rehabilitation Cost	10,000
				Total Cost of Associated Work	20,000
				Total Cost	<u>30,000</u>
				City of Hamilton Share @ 100%	30,000

Element Group	Element	Repair/Rehabilitation Required	Priority	Cost	Comments
6	BCI: 0.00				<i>Inspected on: 16-May-12</i>
ARL (Dartnall Road)					
Connection	> Walkway Arm	Rehabilitation	Within 1yr	14,000	Replace clamps
Connection	> Sign	Rehabilitation	Within 1yr	1,000	Replace clamp
				Total Repair/Rehabilitation Cost	15,000
				Total Cost of Associated Work	15,000
				Total Cost	<u>30,000</u>
				City of Hamilton Share @ 100%	30,000
7	BCI: 0.00				<i>Inspected on: 16-May-12</i>
ARL (Upper Gage Avenue)					
Connection	> Walkway Arm	Rehabilitation	Within 1yr	8,000	Replace clamps
Connection	> Sign	Rehabilitation	Within 1yr	2,000	Replace clamp
				Total Repair/Rehabilitation Cost	10,000
				Total Cost of Associated Work	14,500
				Total Cost	<u>24,500</u>
				City of Hamilton Share @ 100%	24,500
8	BCI: 0.00				<i>Inspected on: 16-May-12</i>
IRL (Upper Wentworth Street)					
Connection	> Sign	Rehabilitation	Within 1yr	5,000	Replace clamp
Diagonal	> Leg	Rehabilitation	Within 1yr	5,000	Repair crack
				Total Repair/Rehabilitation Cost	10,000
				Total Cost of Associated Work	20,000
				Total Cost	<u>30,000</u>
				City of Hamilton Share @ 100%	30,000

Element Group	Element	Repair/Rehabilitation Required	Priority	Cost	Comments
9	BCI: 0.00				<i>Inspected on: 16-May-12</i>
ARL (Mohawk Rd./Golf Links Rd.)					
Connection	> Sign	Rehabilitation	Within 1yr	5,000	Tighten bolts and replace clamps
Sign Foundatio	> Concrete	Rehabilitation	Within 1yr	5,000	Patch concrete
Connection	> Walkway Arm	Rehabilitation	Within 1yr	5,000	Replace clamps
Diagonal	> Truss	Rehabilitation	Within 1yr	5,000	Repair cracks
Total Repair/Rehabilitation Cost				20,000	
Total Cost of Associated Work				21,000	
Total Cost				<u>41,000</u>	
City of Hamilton Share @ 100%				41,000	

City of Hamilton

2017 Sign Support Inspections Summary Report

Prepared by:

AECOM

50 Sportsworld Crossing Road, Suite 290

Kitchener, ON, Canada N2P 0A4

www.aecom.com

519.650.5313

tel

519.650.3424

fax

Distribution List

# Hard Copies	PDF Required	Association / Company Name
1	√	City of Hamilton



AECOM

50 Sportsworld Crossing Road, Suite 290
Kitchener, ON, Canada N2P 0A4
www.aecom.com

519.650.5313 tel
519.650.3424 fax

November 17, 2017

Ed Switenky CET
Superintendent Traffic Operations
City of Hamilton
Traffic Operations Centre
1375 Upper Ottawa Street
Hamilton, Ontario L8W 3L5

Dear Mr. Switenky:

Project No: 60554463

Regarding: 2017 Sign Support Inspections Summary Report

AECOM is pleased to submit this report with respect to the results of the 2017 City of Hamilton Sign Support Inspections.

The structures were reviewed in accordance with the most current version of the Sign Support Inspection Guidelines.

With this report, all sign support structure related data has been updated to present day values and the content of the report reflects the conditions as of the time of the field data collection.

We trust that this report will be beneficial to the City and wish to express appreciation for the opportunity for AECOM to undertake this work.

Sincerely,
AECOM Canada Ltd.



Scott Davis, P.Eng MASc
Manager Roads and Engineering
Scott.davis@aecom.com

PSD:cbl
Encl.
cc: file

Statement of Qualifications and Limitations

The attached Report (the "Report") has been prepared by AECOM Canada Ltd. ("AECOM") for the benefit of the Client ("Client") in accordance with the agreement between AECOM and Client, including the scope of work detailed therein (the "Agreement").

The information, data, recommendations and conclusions contained in the Report (collectively, the "Information"):

- is subject to the scope, schedule, and other constraints and limitations in the Agreement and the qualifications contained in the Report (the "Limitations");
- represents AECOM's professional judgement in light of the Limitations and industry standards for the preparation of similar reports;
- may be based on information provided to AECOM which has not been independently verified;
- has not been updated since the date of issuance of the Report and its accuracy is limited to the time period and circumstances in which it was collected, processed, made or issued;
- must be read as a whole and sections thereof should not be read out of such context;
- was prepared for the specific purposes described in the Report and the Agreement; and
- in the case of subsurface, environmental or geotechnical conditions, may be based on limited testing and on the assumption that such conditions are uniform and not variable either geographically or over time.

AECOM shall be entitled to rely upon the accuracy and completeness of information that was provided to it and has no obligation to update such information. AECOM accepts no responsibility for any events or circumstances that may have occurred since the date on which the Report was prepared and, in the case of subsurface, environmental or geotechnical conditions, is not responsible for any variability in such conditions, geographically or over time.

AECOM agrees that the Report represents its professional judgement as described above and that the Information has been prepared for the specific purpose and use described in the Report and the Agreement, but AECOM makes no other representations, or any guarantees or warranties whatsoever, whether express or implied, with respect to the Report, the Information or any part thereof.

Without in any way limiting the generality of the foregoing, any estimates or opinions regarding probable construction costs or construction schedule provided by AECOM represent AECOM's professional judgement in light of its experience and the knowledge and information available to it at the time of preparation. Since AECOM has no control over market or economic conditions, prices for construction labour, equipment or materials or bidding procedures, AECOM, its directors, officers and employees are not able to, nor do they, make any representations, warranties or guarantees whatsoever, whether express or implied, with respect to such estimates or opinions, or their variance from actual construction costs or schedules, and accept no responsibility for any loss or damage arising therefrom or in any way related thereto. Persons relying on such estimates or opinions do so at their own risk.

Except (1) as agreed to in writing by AECOM and Client; (2) as required by-law; or (3) to the extent used by governmental reviewing agencies for the purpose of obtaining permits or approvals, the Report and the Information may be used and relied upon only by Client.

AECOM accepts no responsibility, and denies any liability whatsoever, to parties other than Client who may obtain access to the Report or the Information for any injury, loss or damage suffered by such parties arising from their use of, reliance upon, or decisions or actions based on the Report or any of the Information ("improper use of the Report"), except to the extent those parties have obtained the prior written consent of AECOM to use and rely upon the Report and the Information. Any injury, loss or damages arising from improper use of the Report shall be borne by the party making such use.

This Statement of Qualifications and Limitations is attached to and forms part of the Report and any use of the Report is subject to the terms hereof.

AECOM: 2015-04-13
© 2009-2015 AECOM Canada Ltd. All Rights Reserved.

Authors

Report Prepared By:



Mario Marin
Bridge Technologist

Report Reviewed By:

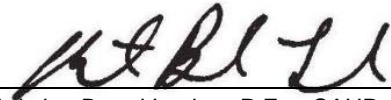

Christine Beard Laaber, P.Eng CAHP
Senior Structural Engineer, Bridge Design,
Transportation



Executive Summary

This report is a summary of the recommendations resulting from the City of Hamilton 2017 Sign Support Inspection Guidelines (SSIG) biennial inspection program. SSIG inspections include a complete element by element detailed visual inspection of the 44 highway sign support structures owned by the City of Hamilton. SSIG inspections provide valuable information for the City of Hamilton SSIG reports combined with upcoming biennial inspections. They are a tool to monitor and plan for the City of Hamilton's sign support infrastructure needs.

Each sign support inspected includes details specific to its condition and recommendations. Of note the maintenance walkways or catwalks should be removed from use due to the prevalence of broken and cracked C Clamps. Site 37 on Nicola Tesla Blvd on the eastbound side ahead of Woodward Ave is in very poor condition and should be removed and replaced.

At other sites an ongoing maintenance program is necessary including drilling of drain holes, welding members, tighten bolts, replacing C clamps, applying coatings, replacing missing members and repairing signs or other attachments as required. A maintenance program will slow the deterioration of the sign supports and ensure that they remain a valuable part of City of Hamilton infrastructure

Table of Contents

	page
1. Introduction	1
1.1 Background	1
2. Methodology.....	1
2.1 Additional Investigations	2
2.2 Maintenance Needs	2
2.3 Repair/ Rehabilitation.....	2
2.4 Structural Ratings	2
3. Situations to Monitor	3
3.1 Site 37	3
3.2 Catwalks/Maintenance Walkways	3
4. Conclusion	4

List of Figures

Figure 1. Summary of 2017 Sign Support Ratings	3
--	---

Appendices

- Appendix A. Map of Sign Support Structures
- Appendix B. Detailed Inspection Methodology
- Appendix C. Maintenance Needs Summary
- Appendix D. Repair/ Rehabilitation Summary
- Appendix E. Structural Ratings

1. Introduction

AECOM Canada Ltd. (AECOM) was retained by the City of Hamilton to complete the 2017 sign support inspections in accordance with the current Sign Support Inspection Guidelines (SSIG). These structures are a vital part of the wayfinding infrastructure for the City of Hamilton and the goal of the SSIG inspections is to ensure that the structures are maintained to an acceptable standard to protect public safety and convenience. In order to ensure an effective structure management system, the SSIG require that systematic inspections be performed every two years on sign support structures. The inspections themselves involve detailed inspections of each element to assess material, performance, and maintenance requirements. In addition to the biennial inspections which are the subject of this report, routine maintenance and inspection by City of Hamilton maintenance crews are essential in identifying changes to structure condition.

1.1 Background

A detailed visual inspection of each of the City of Hamilton's sign support structures was completed as part of the 2017 inspections in coordination with Burgess Engineering Inc. SSIG inspections were completed by using cameras and accessed by climbing where the condition of the structure permitted. The inspections were previously completed in 2012. By conducting biennial inspections, any new visible deterioration and progression of deterioration can be monitored. A city map indicating the sites inspected is included in **Appendix A**. GPS Coordinates used for the mapping are included in the individual reports. The coordinates are taken at the right leg (in direction of traffic) at each structure.

The purpose of the report is to clearly identify the current and future physical and financial needs of the City of Hamilton with respect to its sign support structures. The report provides a rating of the general condition of the structures. The report information can be used for high level planning and budgeting. However, once a structure reaches the project design stage, further detailed review, investigation and design will be required to address the specific requirements of the project.

2. Methodology

A consistent approach to structure inspections is required for an SSIG inspection. The SSIG provides the framework to ensure that individual inspectors consider each element consistently every two years. The SSIG goes so far as to define the types of material defects and the grade of their severity in order to ensure that each inspector designates each deficiency and deterioration similarly. In addition, the SSIG inspection process requires the inspector to provide recommendations with regard to additional investigations, maintenance, and repair needs along with the urgency. Furthermore, inspectors are further required to identify performance deficiencies.

In Hamilton 6 types of sign support structures were inspected. Terminology, sample deficiencies and each type of structure are described in a more detailed document in **Appendix B**.

2.1 Additional Investigations

During structural inspections the need for detailed investigations may be identified. Examples of additional investigations include:

- Ultrasonic testing (UT) of the anchor bolts; and
- Liquid Penetrant Testing (LPT) of welds.

Non destructive testing (NDT) using liquid penetrant was used at Site 37 to show excessive weld cracking. Photographs and descriptions are included with the individual inspection.

2.2 Maintenance Needs

Maintenance work includes routine maintenance as well as targeted structural repairs. Maintenance is not typically considered capital work. Routine maintenance can prolong the life of a structure, but may include urgent safety items which are not structural. In several of the reports the drilling of drain holes is recommended under maintenance. Drain holes can allow the free drainage of water from a steel element and prevent cracking from expanded trapped moisture which freezes. Routine maintenance does not require engineering direction and can typically be performed by the City of Hamilton's maintenance personnel. Structural maintenance work may include emergency repairs to restore structural capacity and requires engineering direction.

A summary of recommended maintenance needs is included in **Appendix C**, with timelines in accordance with the urgency of the maintenance requirement. Urgent repairs are typically safety oriented. 1 year maintenance repairs should usually be part of the regular routine maintenance for a structure, and the 3 year timeframe applies to elements which will affect the long term durability of the structure.

2.3 Repair/ Rehabilitation

Where an element is identified as having all or a portion of material in the poor condition state, maintenance, a repair, or rehabilitation is recommended. Rehabilitations are typically recommended for small elements that require replacement, minor weld repairs, or concrete patch repairs. The recommended work includes a timeframe of 1 month, 1 year or 3 years. The recommended timing of a repair is related to the quantity of deterioration and whether the element is critical to the structure. A greater amount of deterioration on a critical element results in the 1 year timeframe being recommended, whereas a less critical repair may warrant the recommendation of a 3 year time frame. Urgent repairs include a recommended timing of 1 month. A summary of the repair and rehabilitation needs for City of Hamilton sign support structures is included in **Appendix C**.

2.4 Structural Ratings

Structural ratings (SSR) are a means of categorizing the structures' overall condition. The ratings and conditions can be used to rank the sign support structures based on the defects and performance of each site. The structure ranking can be used as a guide for programming repairs and replacement. The overall condition of each site based on the SSR is as follows:

- Excellent where SSR >95
- Good where SSR >75
- Fair where SSR >40
- Poor where SSR <40

A summary of SSR for City of Hamilton structures is included in **Appendix D**. The percentage of sign supports in each category in 2017 is provided in **Figure 1**.

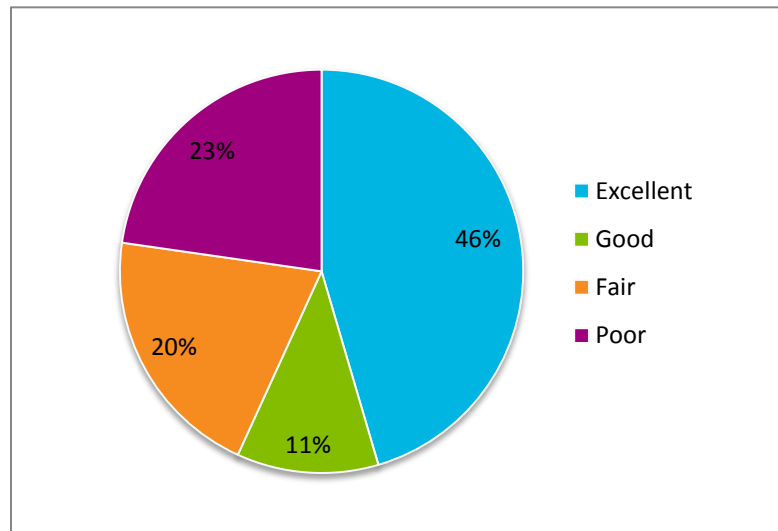

Figure 1. Summary of 2017 Sign Support Ratings

3. Situations to Monitor

3.1 Site 37

Site 37 is an Aluminum Tapered Leg (ATL) sign support located on the Nicola Tesla Blvd on the eastbound side ahead of Woodward Ave. Liquid Penetrant non destructive testing was done at this site on several cracked welds and in addition welds were visually observed to have cracked. Bolt corrosion in the truss, chord and support legs reduce the serviceability of this structure. In addition loose bolts in the walkway and support base and cracked clamps represent a hazard. The Structure Support rating is poor at -384; this sign support is in the worst condition of the supports that were safe enough to climb. This sign should be removed and replaced within a month to protect public safety.

3.2 Catwalks/Maintenance Walkways

It is recommended that the Catwalks to install or maintain signs be removed and their use prohibited. The catwalks for Aluminum Rectangular Leg (ARL) signs in particular should be removed. This includes Sites 2, 3, 6 and 7. The C-Clamps used to support the catwalks are cast with a crack-susceptible steel. The clamps are often cracked and can result in a safety issue if the catwalks are used. It is recommended that Catwalks be removed. Further details regarding the maintenance walkway catwalks and the issues surrounding the cracked C-Clamps are included in **Appendix B**.

4. Conclusion

SSIG inspections were completed on 44 bridge structures in the City of Hamilton. The City of Hamilton will need to continue to contemplate increasing repair and rehabilitation costs for its aging sign support structure infrastructure to protect its assets and the public safety. The City of Hamilton may find that for some structures deterioration begins to accelerate, whereas other structures may stabilize allowing the deferral of repairs. As a result, the maintenance, rehabilitation and repair needs should continue to be updated in upcoming biennial inspections.

Appendix **A**

Sign Support Location Map

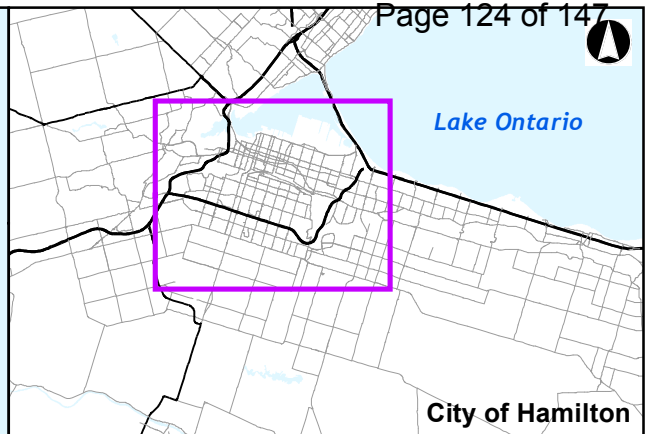
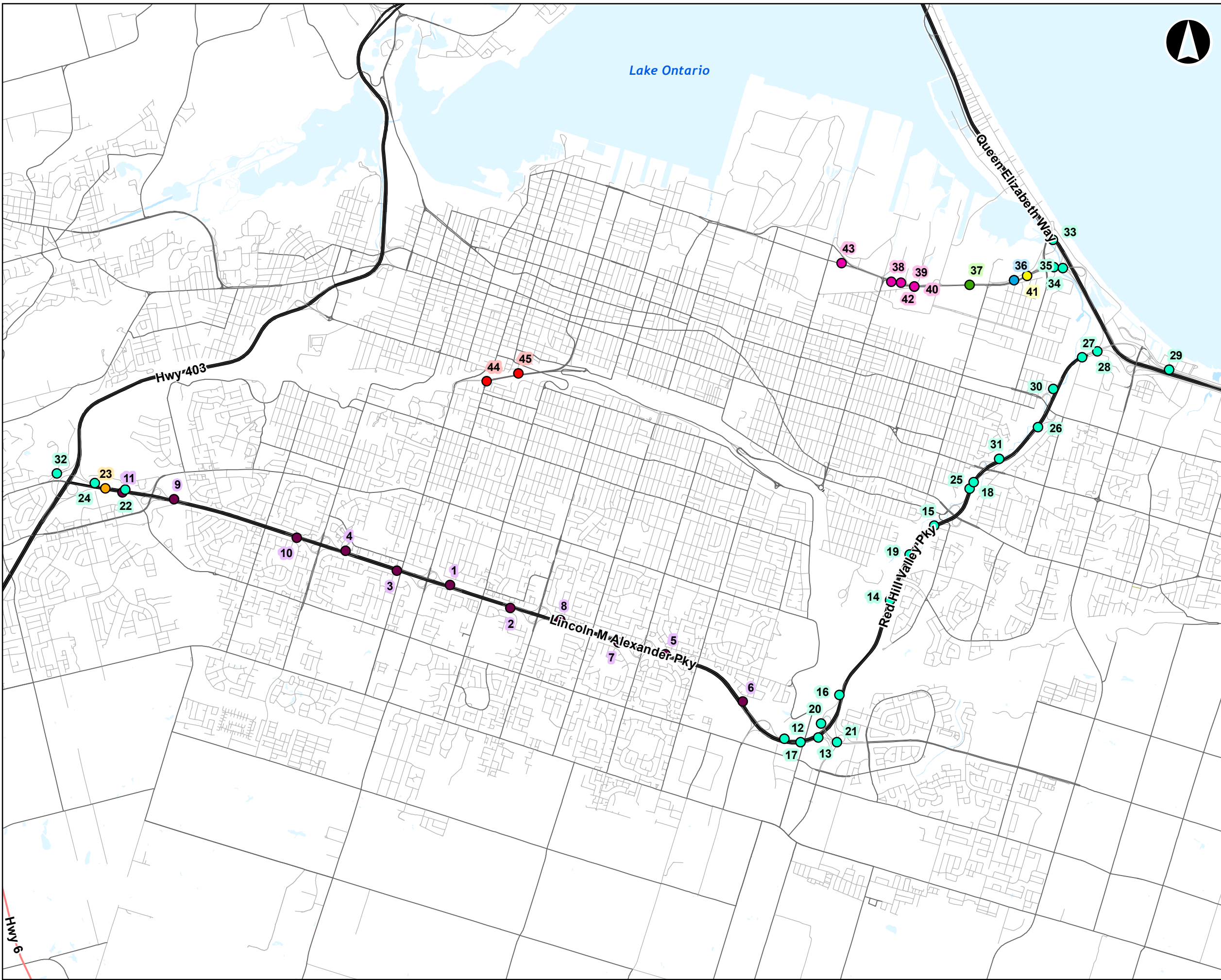

Legend

- Freeway
- Expressway / Highway
- Major Road
- Local Road
- Ramp
- Alleyway / Laneway
- Rapid Transit
- Service
- Lake
- River

Sign Structure Type

- Aluminum Rectangular Leg
- Aluminum Tapered Leg
- Cantilever
- Cantilever Class 2
- Monotube
- Sign Removed
- TriChord
- Variable Message Sign

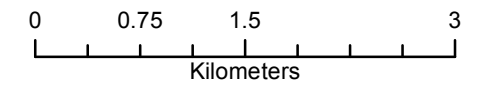

City of Hamilton Signs

Sign Support List for the City of Hamilton, Ontario

Oct 2017	1:54,000 <small>* when printed 11"x17"</small>	Datum: NAD 1983 UTM Zone 17N Source: MNRF
P#: 60554463	V#: 001	

AECOM **Figure 1**

This drawing has been prepared for the use of AECOM's client and may not be used, reproduced or relied upon by third parties, except as agreed by AECOM and its client, as required by law or for use by governmental reviewing agencies. AECOM accepts no responsibility, and denies any liability whatsoever, to any party that modifies this drawing without AECOM's express written consent.

Hwy 6

\\s01\sharepoint\GIS\Projects\2017\2017_04_14_Sign_Support_List\GIS\Graphics\Layouts\1_Reports\Sign_Support_List\Sign_Support_List.hamilton.mxd
Date Saved: 10/26/2017 1:49:56 PM User Name: Stephanie Chouler

Appendix **B**

Detailed Inspection Methodology



Overhead Sign Support Structure Inspection Report City of Hamilton, October 2017.

Background and Detailed Methodology

As a part of the City of Hamilton's overhead sign support inspection program, Burgess Engineering Inc. was retained to inspect and report on the condition of forty-four overhead sign support structures. The following are the various structure types covered in this report.

Aluminum Rectangular Leg (ARL) - The general arrangement of this structure is shown below.

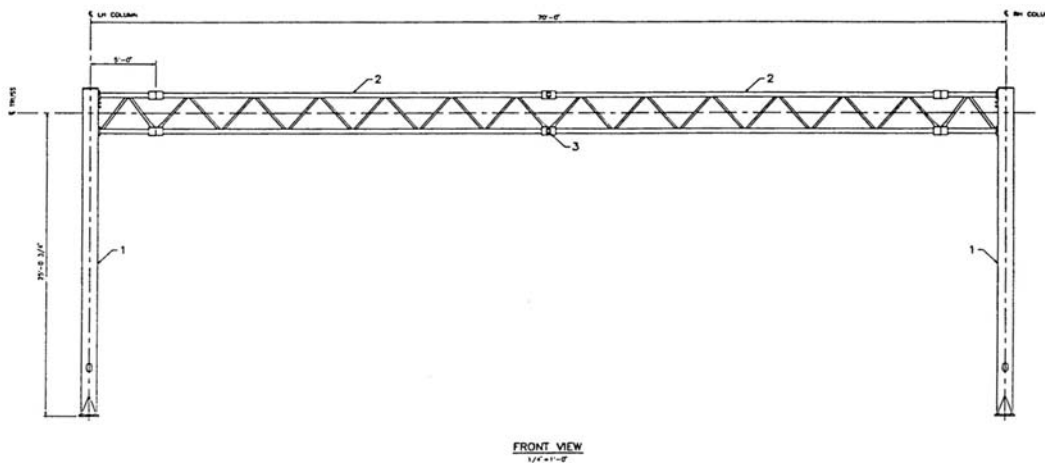

Aluminum Tapered Leg (ATL) - The general arrangement of this structure is shown below.

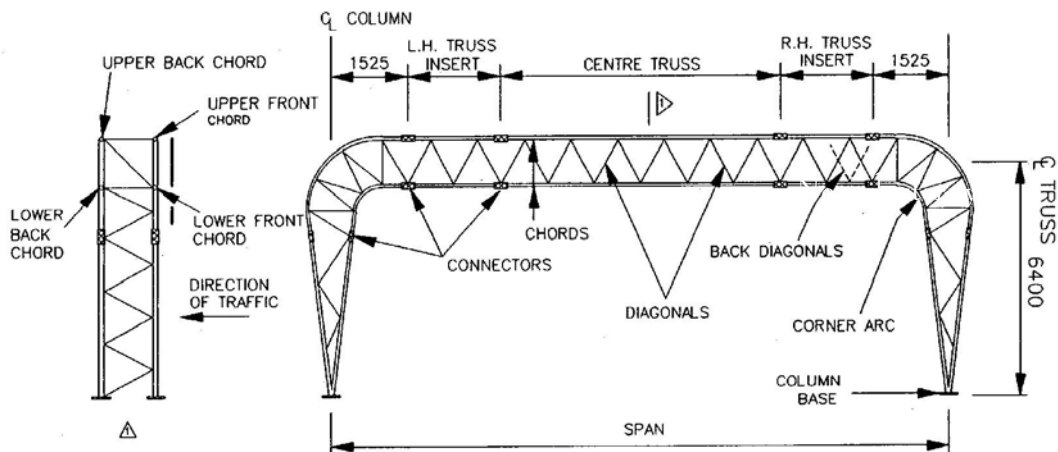

Burgess Engineering Inc., Consulting Engineers
137 Lake Street, Grimsby, ON, L3M 4M6
(905) 741-5427, email: bei@mailburgesseng.com





Overhead Sign Support Structure Inspection Report City of Hamilton, October 2017.

Tri-Chord - The general arrangement of this structure is shown below.

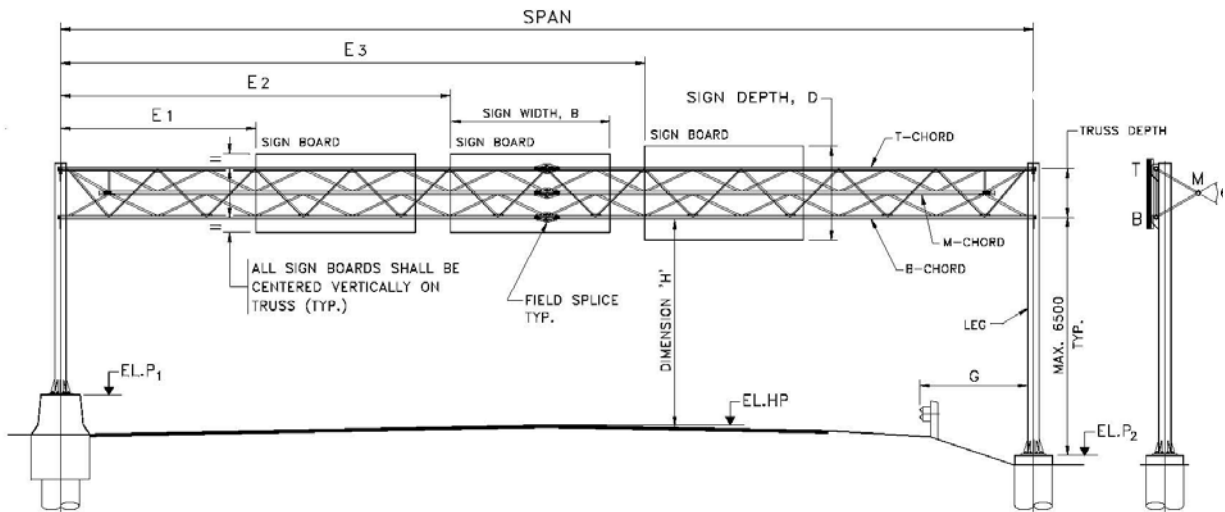

Mono-tube - The general arrangement of this structure is shown below.

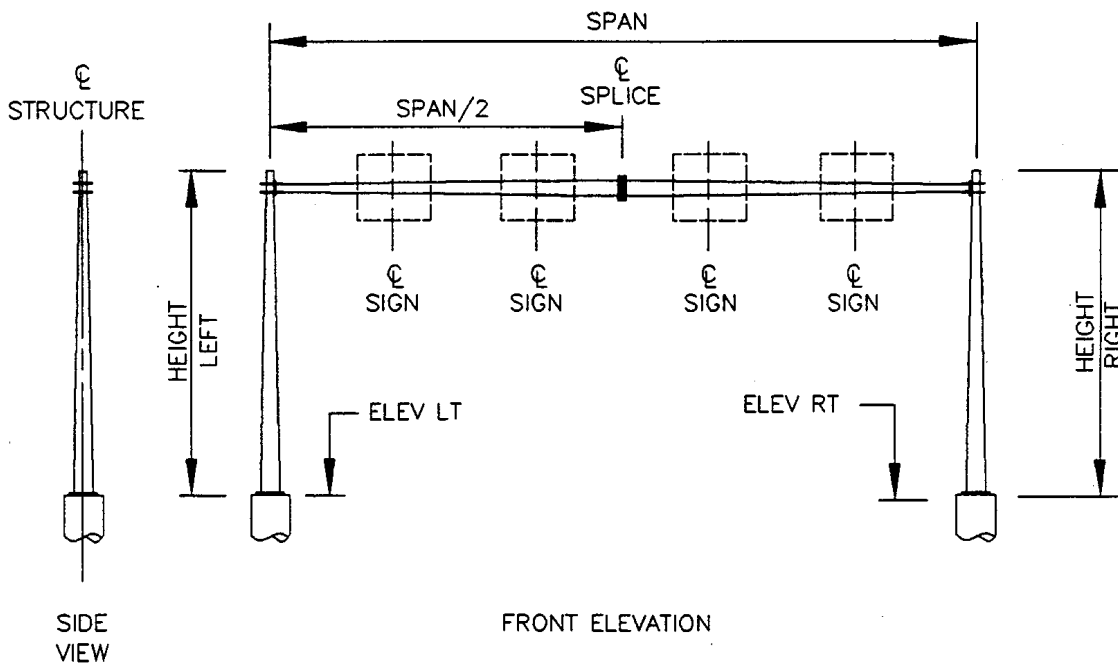



Overhead Sign Support Structure Inspection Report City of Hamilton, October 2017.

Cantilever support - The general arrangement of this structure is shown below:

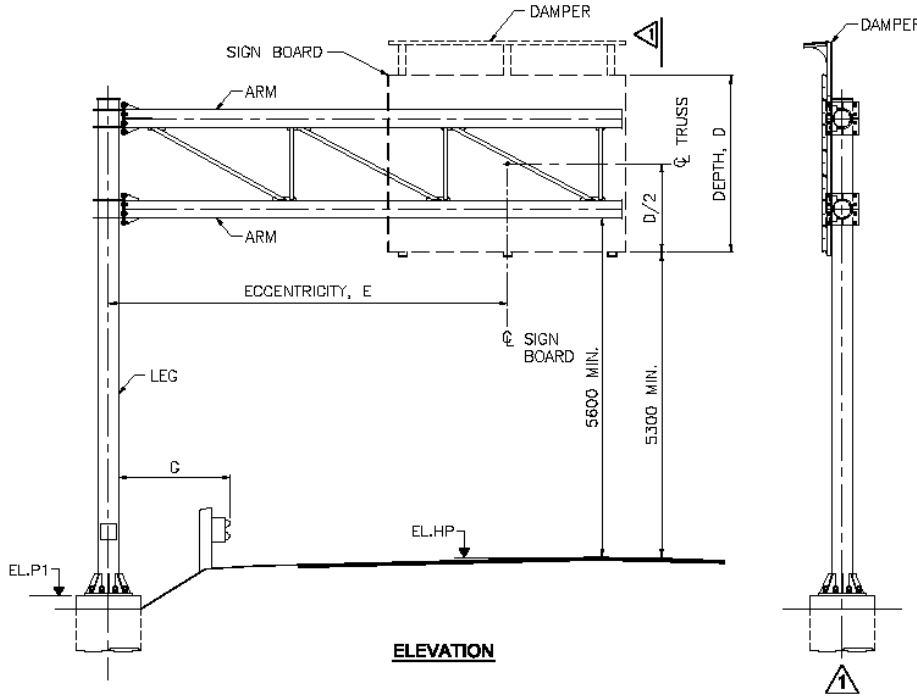

Walk-in CMS - The general arrangement of this structure is shown below:

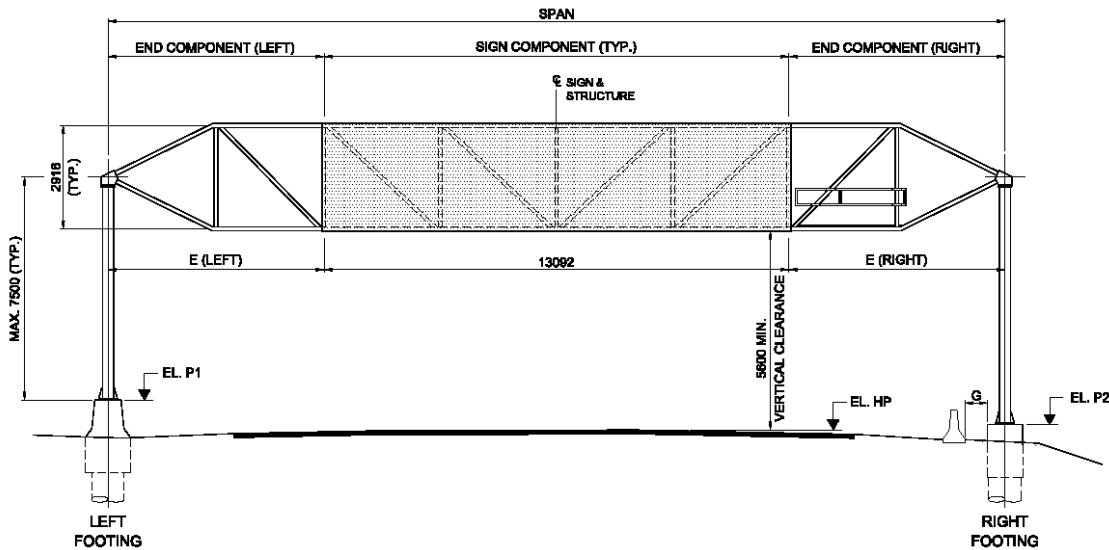



Overhead Sign Support Structure Inspection Report City of Hamilton, October 2017.

All structures were inspected in detail and deficiencies requiring repair were flagged with trail blazing tape and are described in each report. In addition to the detailed visual inspection, site #37 was subjected to non-destructive testing. Photographs of each test are given with the test findings documented. At the time of inspection the global positioning coordinates were taken from the right leg.

Inspection Terminology & Method of Repair

The following terminology is referenced throughout the reports:

Terminology	Description	Repair Methodology
Initial Cracking	Start of weld crack propagation.	Weld & grind smooth
% Cracked	The % of weld length that has cracked.	Weld & grind smooth
Bent	A member has been impacted.	Complete member replacement with equal
Split	A member has ruptured, typically from freezing of entrapped water.	Complete member replacement with equal & drill drain holes
Cracked or Broken Sign 'C' Clamp	An aluminum casting that affixes the sign to the chords.	Replacement with equal, or better to eliminate ongoing replacement
Cracked or Broken Walkarm 'C' Clamp	An aluminum casting that affixes the catwalk arm to the chords.	Replacement with equal, or better to eliminate ongoing replacement
Loose bolts (walkarm, 'C' clamp, cluster, 'T' bar...)	Loose bolts, typically installed in this manner.	Tighten to a snug tight condition as defined in the Steel handbook

All inspections and report documentation were completed in accordance with the Sign Support Inspection Guidelines (SSIG).

Burgess Engineering Inc., Consulting Engineers
137 Lake Street, Grimsby, ON, L3M 4M6
(905) 741-5427, email: bei@mailburgesseng.com





Overhead Sign Support Structure Inspection Report City of Hamilton, October 2017.

General Inspection Comments

The following describes findings commonly observed. It should be noted that typically the deficiencies documented in these reports are not a result of externally applied loads (ie. wind) causing structural distress and fatigue. They were either present at the time of erection, a result of long-term corrosion, lack of member drainage or vehicle impact. The concern is that these structures are non-redundant and once a member is deficient, regardless of the cause, the support becomes unstable and failure may result under normal loadings.

Cracked C-clamps

C-Clamps are used to support both the sign boards and the maintenance walkway. These clamps are constructed of a brittle casting and various factors result in cracking. These factors are: quality of casting, over tightening, imperfections of mating chord, and excessive structure movements/vibrations. The most critical C-clamps are the maintenance walkway support arms. Two clamps support each arm; one on the front and one on the back. The critical of these two is the front. When this support is lost (broken C-clamp) the walk arm can rotate around the back chord and is no longer supported (depicted below).

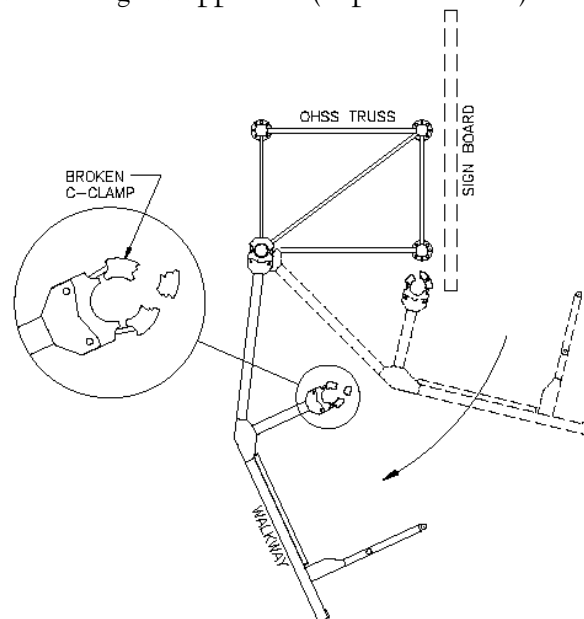



Overhead Sign Support Structure Inspection Report City of Hamilton, October 2017.

This is the reason that the maintenance walkway should not be utilized until all crack/broken C-clamps are replaced. Of particular concern are all front clamps. After replacement, a general inspection is still recommended prior to each use of the maintenance catwalk. During the design of the first overhead sign support (1960's) the main reason for the catwalks was to provide support for lighting and access to allow sign re-facing (overlay). Due to today's long life span of sign reflective sheeting signs no longer require lighting and/or re-facing. Based on this we recommend all catwalks be removed. This will dramatically reduce ongoing maintenance, reduce the dead load on the support and inhibit further vandalism.

Re-design of the sign clamp should be considered to eliminate on-going clamp replacement and reduce the risk of injury. One design by Burgess Engineering Inc. that has been successfully installed is depicted:



Debris at Base

The base of several structures is covered with debris and in some cases the base could not be inspected. This debris should be removed to reduce the rate of deterioration and allow for inspection.

This issue is more critical for structures with leveling nuts. The debris increases the rate of corrosion of the critical leveling nuts. The top of the footings for these structure types should be pressure washed on a routine basis.



Overhead Sign Support Structure Inspection Report City of Hamilton, October 2017.

Drain Holes Required

Several members have a drain hole (originally meant to vent gasses during fabrication) at the top only. Entrapped water expands during freezing and splits the member. All members should have a hole located at the lowest region outside of the weld to allow for proper draining. In addition, field replaced members should also have proper drainage. It is important that all holes are located at the lowest part of the member to allow full member drainage. Holes should never be drilled elsewhere (ie. top of the member).

Removal of Electrical Equipment

A majority of the older generation sign supports still have the old electrical equipment in place. This equipment is no longer required and in many instances has advanced deterioration. The concern is that some of these elements may eventually fall from its support. All old electrical equipment should be removed to avoid possible vehicle/pedestrian hazard.



Overhead Sign Support Structure Inspection Report City of Hamilton, October 2017.

Diagonal to Cluster Weld Cracking

As documented in previous reports and as seen in this report, several structures have advanced cluster bolt corrosion resulting in extensive diagonal to cluster weld cracking. The below photograph generally describes this area:

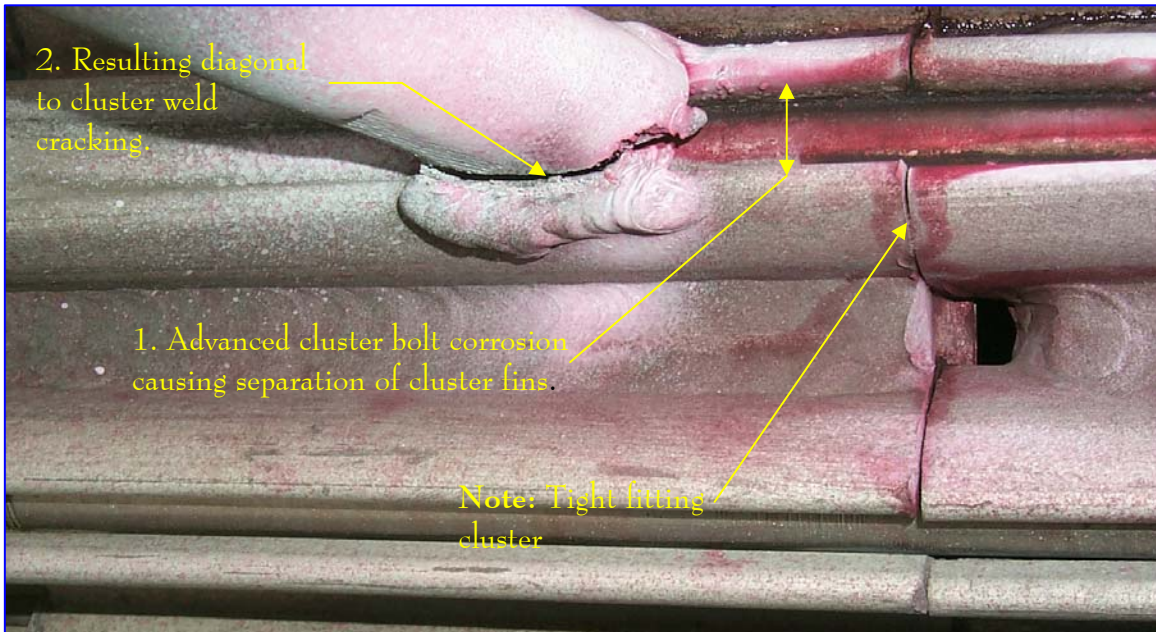

This problem typically occurs in the lower horizontal clusters of older ATL and ACL structures. One factor that affects the advancement of this cracking is the degree of water tightness between the two adjoining clusters. A tight fitting connection retains water, which increases the rate of deterioration of the cluster bolt. For each site-specific condition refer to the individual inspection summaries.



Overhead Sign Support Structure Inspection Report City of Hamilton, October 2017.

The below photograph depicts further weld cracking of this area after repairs were completed in a relatively short time period. Continuing corrosion build up between the cluster bolt and the fins is causing the fins to further separate. This results in on-going weld cracking and continuous weld repair. To eliminate the need for this on-going repair work it is recommended that this area be modified.



As previously mentioned, this problem mainly occurs for the ATL and the ACL. Historically this is because the ARL have not been in service long enough to allow for the cluster bolt corrosion. However, several ARL supports have started to show initial signs of this issue. It is recommended that this area be modified to eliminate on-going maintenance needs and possible failure.



Overhead Sign Support Structure Inspection Report City of Hamilton, October 2017.

One approach as designed by Burgess Engineering Inc. is depicted below. This was successfully completed on several MTO, Advanced Traffic Management ARL.



In this approach the bolt that corrodes and causes the weld cracking is removed and replaced with two exterior bolts. It should be noted that at the time of this retrofitting all damaged and cracked areas should be repaired. Once this is completed the need for on-going weld repair will be eliminated.

Critical Structures Requiring “1 Month” Repair

Priority should be given to all structures having a lower structural rating and/or “1 Month Needs”. It should be noted that all of the sign supports inspected are non-redundant and all truss members are primary and critical to the supports integrity.

Burgess Engineering Inc., Consulting Engineers
137 Lake Street, Grimsby, ON, L3M 4M6
(905) 741-5427, email: bei@mailburgesseng.com





Overhead Sign Support Structure Inspection Report City of Hamilton, October 2017.

Inspection and Report Methodology

The following section describes the inspection and report format.

Photographs

During the inspection, three general photographs were taken, the Elevation, Left Leg & Right Leg. In addition, a photograph was taken of each structure deficiency and Non-destructive test. All photographs are provided and described in each report.

Non-destructive Testing

The test findings are summarized on the subject photograph with the following abbreviation:

No Linear Indications Observed (liquid penetrant) - N.L.I.O.

No Relevant Indicators Observed (ultrasonic) - N.R.I.O.

If a deficiency was noted, the corrective measures are stated in the rehab needs field with an associated time period.





Overhead Sign Support Structure Inspection Report City of Hamilton, October 2017.

Location (node numbering) of Deficiency or NDT

ATL

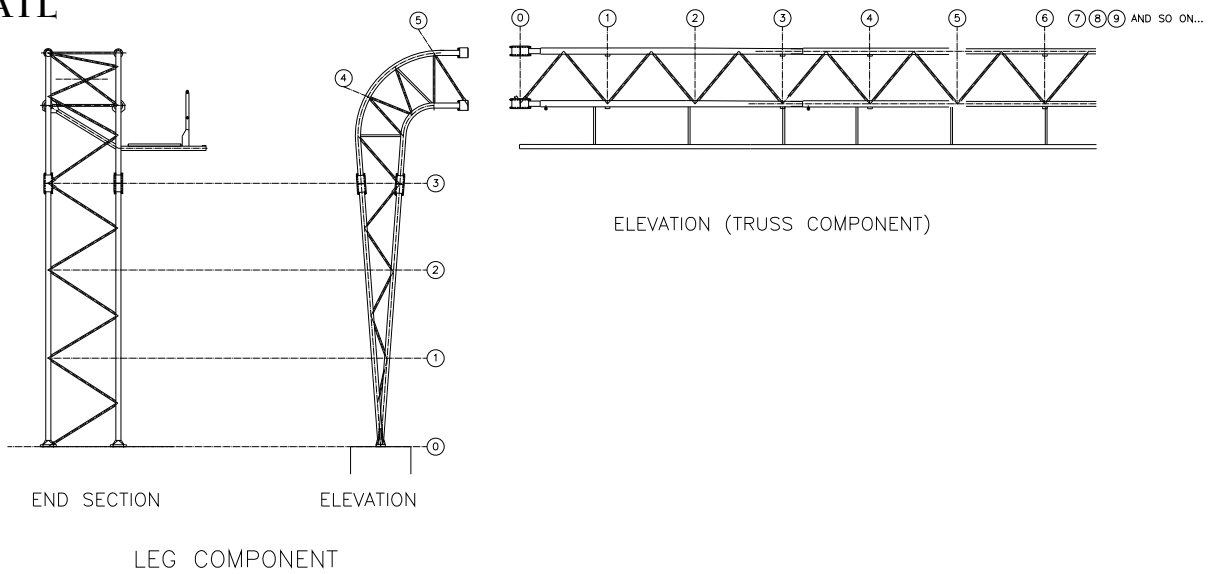

ARL

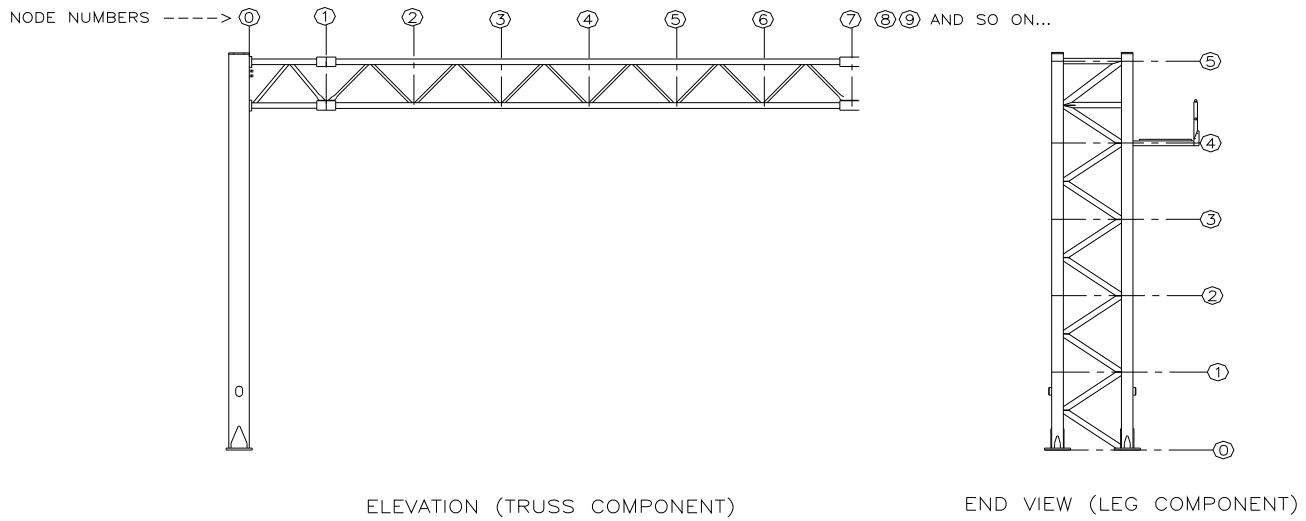



Overhead Sign Support Structure Inspection Report City of Hamilton, October 2017.

Cantilever

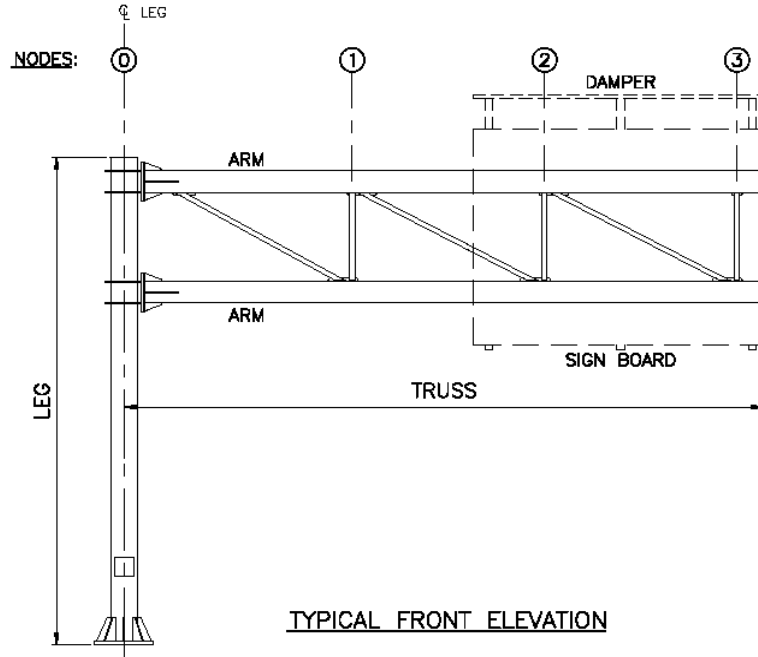

Tri-Chord

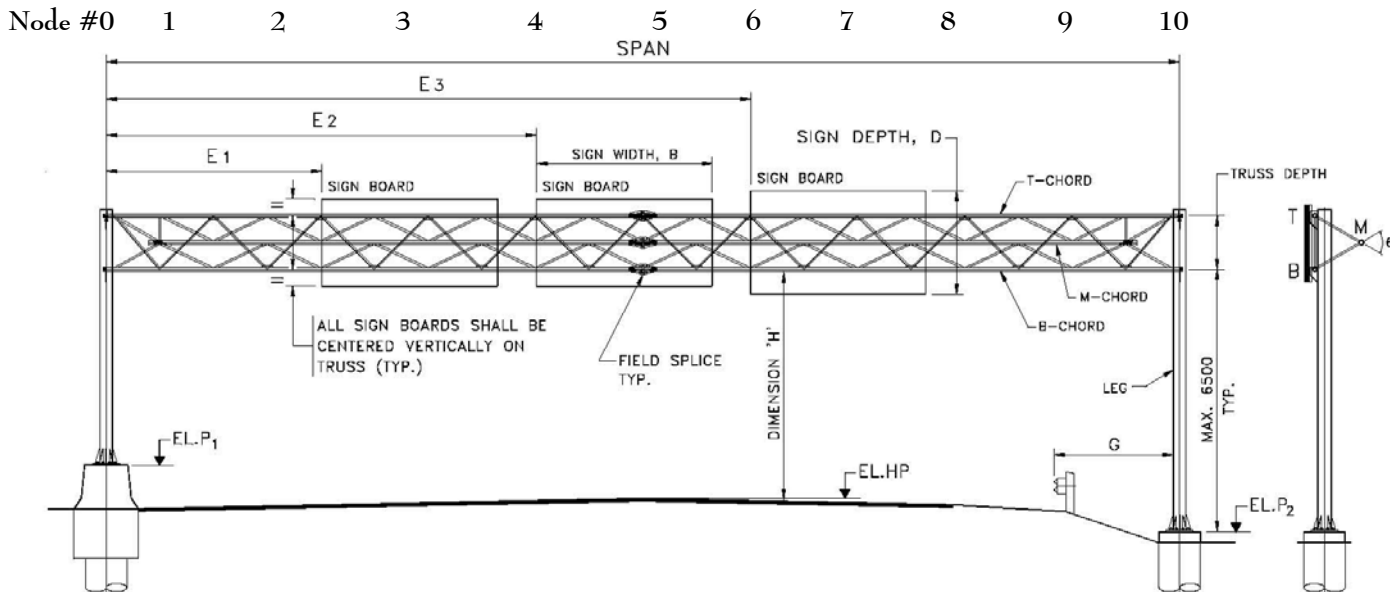

Appendix **C**

Maintenance Needs Summary

2017 Maintenance Needs

Site Number	Structure Name	Structure Type	Element Name	Element Group	Maintenance Needs	Comments	Timing
1	Upper James Street - Exit	ARL	Truss Diagonals	Diagonal	Drill Drain Hole	Recommend drain holes be drilled at the bottom of each diagonal to allow for water drainage to avoid member cracking, resulting from freezing of entrapped water.	3 years
2	Upper Wentworth St - EXIT	ARL	Base Connections	Connection	Minor Repair of Sign or Other Attachment (17)	Weld interference preventing washer to be flush with base plate. Recommend grind side of washer and tighten anchor bolt.	1 year
2	Upper Wentworth St - EXIT	ARL	Truss Diagonals	Diagonal	Drill Drain Hole, Repair Weld	Various missing drain holes at truss clusters. Truss, back, lower, N-1: Severed weld, gap between diagonal and cluster fin.	1 year
3	Upper James Street - EXIT	ARL	Truss Diagonals	Diagonal	Drill Drain Hole	Various missing drain holes at truss clusters.	3 years
6	Dartnall Road - EXIT	ARL	Truss Diagonals	Diagonal	Drill Drain Hole	Various missing drain holes at truss clusters.	3 years
7	Upper Gage Avenue - EXIT	ARL	Truss Diagonals	Diagonal	Drill Drain Hole	Various missing drain holes at truss clusters.	3 years
10	Garth Street - EXIT	ARL	Truss Diagonals	Diagonal	Drill Drain Hole	Various missing drain holes at truss clusters.	3 years
		ARL	Foundation	Concrete	Remove Vegetation	Vegetation over growth.	3 years
11	Golf Links/Mohawk Rd - EXIT	ARL	Truss Diagonals	Diagonal	Drill Drain Hole, Repair Weld	Various missing drain holes at truss clusters. Truss, back, upper, N-18: 30 mm weld crack.	1 year
21	Lincoln M. Alexander Parkway - EXIT	Tri-Chord	Accessory Connection	Connection	Minor Repair of Sign or Other Attachment (17)	Right Leg: Loose leg cap bolt.	1 year
22	403 Brantford, 403 Toronto Split - ADVANCED	Tri-Chord	Other - Accessory	Attachment	Minor Repair of Sign or Other Attachment (17)	Left leg, lower: Missing chord end cap.	1 year
39	Strathearne Ave./Parkdale Ave. - ADVANCED	Non Std. Cantilever	Other - Accessory	Attachment	Minor Repair of Sign or Other Attachment (17)	Missing front and back cover plates.	1 year
42	Hamilton Ave. Local Access - EXIT	Non Std. Cantilever	Other Accessory	Attachment	Minor Repair of Sign or Other Attachment (17)	Loose arm end cap, lower.	1 year
43	Nikola Tesla Boulevard - EXIT	Non Std. Cantilever	Other Accessory	Attachment	Minor Repair of Sign or Other Attachment (17)	Missing leg end cap.	1 year
		Non Std. Cantilever	Sign	Connection	Minor Repair of Sign or Other Attachment (17)	Bent flat bar supporting down arrows. Sign Connection, lower: Lack of bolt protrusion.	1 year
44	Upper James St. & West 5th St. - SPLIT	Monotube	Other Accessory	Attachment	Minor Repair of Sign or Other Attachment (17)	Right leg: Missing end cap and front cover plate.	1 year

Appendix **D**

Repair/Rehabilitation Summary

2017 Repair/ Rehabilitation Needs

Site Number	Structure Name	Structure Type	Element Group	Element Name	Performance deficiencies	Description	Comments	Rehab time period
1	Upper James Street - Exit	ARL	Connection	Walkway Arm Connection	Load carrying capacity	Replace walkarm C-clamp	Loose walkarm clamp. Truss, back, lower, N-12. Cracked walkarm clamp (Back - 5"), Truss, back, lower, N-11 & Truss, back, lower, N-10, Cracked walkarm clamp (5"). Truss, back, lower, N-15: & Truss, front, lower, N-7.	1 Month
2	Upper Wentworth St - EXIT	ARL	Diagonal	Truss Diagonals	Load carrying capacity	Cluster modification & re-weld	Various missing drain holes at truss clusters. Truss, back, lower, N-1: Severed weld, gap between diagonal and cluster fin.	1 Month
		ARL	Connection	Sign Connection	None	Replace sign C-clamp	Cracked sign clamp (back, 5"): Truss, front, lower, N-12, Truss, front, upper, N-12 & Truss, front, upper, N-10. Broken sign clamp (back, 5"): Truss, front, upper, N-8, truss, front, upper, N-4 & truss, front, upper, N-3.	1 Month
		ARL	Connection	Walkway Arm Connection	Load carrying capacity	Replace walkarm C-clamp	Cracked walkarm clamp (5"): Truss, front, lower, N-13 & Truss, back, lower, N-8,	1 Month
3	Upper James Street - EXIT	ARL	Connection	Sign Connection	Load carrying capacity	Replace sign C-clamp	Cracked sign clamp (back, 5"): Truss, front upper, N-9, Truss, front, lower, N-9 & Truss, front, upper, N-5. Cracked sign clamp (5"): Truss, front, upper, N-6. Broken sign clamp (back, 5"): Truss, front, upper, N-4 & Truss, front, upper, N-3.	1 Month
		ARL	Connection	Walkway Arm Connection	Load carrying capacity	Replace walkarm C-clamp	Cracked walkarm clamp (back, 5"): Truss, back, lower, N-9 & Truss, back, lower, N-8. Broken walkarm clamp (back, 5"): Truss, back, lower, N-7, Truss, back, lower, N-6 & Truss, back, lower, N-3.	1 Month
4	Garth Street - EXIT	ARL	Diagonal	Truss Diagonals	None	Weld member	Truss, front, lower, N-16: Split in diagonal.	3 Years
		ARL	Connection	Sign Connection	None	Replace sign C-clamp	Cracked sign clamp (Back portion - 5"): Truss, front, upper, N-9, Truss, front, lower, N-9 & Truss, front, lower, N-10.	3 Years
5	Upper Gage Avenue - EXIT	ARL	Connection	Walkway Arm Connection	None	Replace walk-arm C-clamp	Truss, front/lower, N-14: Cracked walkarm clamp (5").	1 Year
		ARL	Connection	Base Connections	None	Tighten bolt	Left leg, front, inside: 1 loose anchor bolt.	1 Year
		ARL	Connection	Sign Connection	None	Replace sign C-clamp	Cracked sign clamp (back portion, 5"), Truss, front/upper, N-2 & Truss, front/upper, N-8.	1 Year

2017 Repair/ Rehabilitation Needs

Site Number	Structure Name	Structure Type	Element Group	Element Name	Performance deficiencies	Description	Comments	Rehab time period
6	Dartnall Road - EXIT	ARL	Connection	Sign Connection	None	Replace Clamp & Tighten bolts	Broken sign clamp (back, 5'): Truss, front, upper, N-4. 2 loose sign T-bar bolts: Truss, front, upper, N-10, Truss, front, lower, N-13) & Truss, front, lower, N-10.	1 Year
		ARL	Connection	Walkway Arm Connection	Load carrying capacity	Replace walk-arm C-clamp	Cracked walkarm clamp (back, 5'): Truss, back, lower, N-6, Truss, back, lower, N-7. Truss, front, lower, N-15 & N-16. Broken walkarm clamp (back, 5'): Truss, front, lower, N-6, Truss, front, lower, N-7, N-8, N-9, N-10, N-11, N-12, N-13, N-14, N-15, N-16.	1 Month
7	Upper Gage Avenue - EXIT	ARL	Connection	Sign Connection	Load carrying capacity	Replace sign C-clamp	Cracked sign clamp (back, 5"): Truss, front, upper, N-9,, Truss, front, upper, N-6, Truss, front, lower, N-4 & Truss, front, upper, N-4. Broken sign clamp (back, 5'): Truss, front, upper, N-8.	1 Month
		ARL	Connection	Walkway Arm Connection	Load carrying capacity	Replace walkarm C-clamp	Broken walkarm clamp (back, 5"): Truss, back, lower, N-10, Truss, back, lower, N-5, Truss, back, lower, N-4, Truss, back, lower, N-3, N-2, & N-1.	1 Month
8	Upper Wentworth St. - EXIT	ARL	Connection	Sign Connection	None	Replace sign C-clamp	Cracked sign clamp (back - 5"): Truss, front, upper, N-8, Truss, front, upper, N-7 & Truss, front, upper, N-2.	1 Year
		ARL	Foundation	Concrete	None	Repair crack/spall in concrete	Left leg, back: Spalled concrete.	3 Years
		ARL	Connection	Base Connections	None	Tighten bolt	Left leg, front: 1 loose anchor bolt.	1 Year
9	Mohawk & Golf Links Rd - EXIT	ARL	Connection	In Line Chord	None	Tighten bolt	Truss, front, upper, N-1: Very loose cluster bolt.	1 Year
		ARL	Connection	Sign Connection	None	Replace sign C-clamp	Cracked sign clamp (back portion - 5"), Truss, front, upper, N-12, Truss, front, lower, N-12, Truss, front, upper, N-6 & Truss, front, upper, N-5. Cracked sign clamp (5"), Truss, front, upper, N-11.	1 Year
		ARL	Connection	Walkway Arm Connection	None	Replace walk-arm C-clamp	Truss, front, lower, N-8: Cracked walkarm clamp (5").	1 Year
		ARL	Foundation	Concrete	None	Repair crack/spall in concrete	Right Leg, Inside: Delaminated/cracked concrete.	1 Year
10	Garth Street - EXIT	ARL	Connection	Walkway Arm Connection	Load carrying capacity	Replace walk-arm C-clamp	Cracked walk-arm clamp (back, 5"): Truss, back lower, N-13, 11, 10, 9, 8, 7, 4, 2 & 1.	1 Month
		ARL	Connection	Sign Connection	None	Replace sign C-clamp	Truss, front, lower, N-11: Cracked sign clamp (back, 5").	1 Year
11	Golf Links/Mohawk Rd - EXIT	ARL	Diagonal	Truss Diagonals	None	Weld member	Various missing drain holes at truss clusters. Truss, back, upper, N-18: 30 mm weld crack.	1 Year
		ARL	Connection	Sign Connection	None	Replace sign C-clamp	Truss, front, upper, N-6: Cracked sign clamp (back, 5").	1 Year
		ARL	Connection	Walkway Arm Connection	None	Replace walkarm C-clamp	Truss, back, lower, N-9: Broken walk-arm clamp (5").	1 Year
		ARL	Diagonal	Leg Diagonal	None	Weld member	Left leg, back, N-5: 40mm weld crack	1 Year

2017 Repair/ Rehabilitation Needs

Site Number	Structure Name	Structure Type	Element Group	Element Name	Performance deficiencies	Description	Comments	Rehab time period
12	Upper Red Hill, Mud Street - EXIT	Tri-Chord	Foundation	Concrete	None	Repair crack/spall in concrete	Left leg, wide cracking in caisson.	3 Years
		Tri-Chord	Coating	Coating - Chords/Main Member	None	Apply Overall Coating	Truss, back chord: coating breakdown.	3 Years
		Tri-Chord	Coating	Coating - Chords/Main Member	None	Apply Overall Coating	Right Leg: Overall coating breakdown.	3 Years
13	Upper Red Hill Valley Parkway - EXIT	Tri-Chord	Coating	Coating - Chords/Main Member	None	Apply Localized Coating	Right Leg: Localized coating breakdown.	3 Years
		Tri-Chord	Connection	Base Connections	Load carrying capacity	Tighten anchor bolts	Right Leg: 8 of 8 anchor bolts are loose. Left leg, 4 of 8 anchor bolts loose.	1 Month
14	Greenhill Avenue - EXIT	Tri-Chord	Connection	Base Connections	None	Tighten anchor bolts	Right Leg: 1 loose anchor bolt and missing all jam nuts.	1 Year
15	King Street - EXIT	Tri-Chord	Connection	Leg Connection	None	Install Member	Left leg, lower: Missing keeper plate.	1 Year
16	Upper Red Hill & Mud Street - EXIT	Tri-Chord	Connection	Leg Connection	None	Install Member	Truss, Lower, N-10: Missing keeper plate.	1 Year
		Tri-Chord	Connection	Base Connections	None	Tighten anchor bolts	Right Leg, inside: 2 loose anchor bolts.	1 Year
17	Dartnall Road - EXIT	Tri-Chord	Coating	Coating - Chords/Main Member	None	Apply Overall Coating	Right Leg: Overall coating breakdown.	3 Years
		Tri-Chord	Coating	Coating - Chords/Main Member	None	Apply Overall Coating	Back Chord, coating breakdown.	3 Years
18	King Street - EXIT	Tri-Chord	Connection	Base Connections	Load carrying capacity	Tighten bolt	Left leg, 6 of 8 anchor bolts loose.	1 Month
19	Greenhill Avenue - EXIT	Tri-Chord	Connection	Base Connections	None	Tighten bolt	Left leg, inside: 1 loose anchor bolt & missing jam nut.	1 Year
20	Upper Red Hill Valley Pkwy - EXIT	Tri-Chord	Connection	Base Connections	None	Tighten anchor bolts	Right Leg: 2 loose anchor bolts.	1 Year
25	Queenston Road - EXIT	Tri-Chord	Connection	In Line Chord	None	Tighten bolt	Truss, bottom Cluster, N-5: Loose cluster bolt. Truss, Middle Cluster, N-5: Loose cluster bolt. Recommend all bolts be tightened/checked.	1 Year
31	Queenston Road - EXIT	Tri-Chord	Diagonal	Truss Diagonals	None	Replace diagonal	Truss, lower, N-9 (left): Diagonal crack.	3 Years
		Tri-Chord	Connection	Base Connections	Load carrying capacity	Tighten bolt	Left leg, 8 of 8 anchor bolts loose.	1 Month
32	Rousseaux Street - EXIT	Tri-Chord	Diagonal	Truss Diagonals	None	Weld member	Truss, Front, Upper, N-3: Crack in truss diagonal.	1 Year
39	Strathearne Ave./Parkdale Ave. - ADVANCED	Non Std. Cantilever	Connection	Base		Tighten anchor bolts	Connection/base: One loose anchor bolt (back/inside).	1 Year
40	Strathearne Ave./Parkdale Ave. - EXIT	Non Std. Cantilever	Connection	Base	Load carrying capacity	Tighten anchor bolts	6 of 8 anchor bolts are loose. Only 2 bolts (front/inside) are working, structure movement.	1 Month
43	Nikola Tesla Boulevard - EXIT	Non Std. Cantilever	Connection	Leg	None	Tighten bolt	Upper connection: Gap between plates resulting from loose bolts.	1 Year
44	Upper James St. & West 5th St. - SPLIT	Monotube	Coating	Chord/Main Member	None	Apply Localized Coating	General overall coating breakdown, consider localized coating in splash zones (base of legs).	1 Year
		Monotube	Coating	Connections	None	Apply Localized Coating	General overall coating breakdown, consider localized coating in splash zones (base of legs).	1 Year

Appendix **E**

Structural Ratings

Structural Rating

Site Number	Structure Name	Structural Rating	Date of Inspection	Span	Total Sign Area	Structure Type
37	Woodward Ave - Advanced	-384	31-Aug-17	22.9	16.7	ATL
6	Dartnall Road - EXIT	-63	15-Sep-17	25.9	25.3	ARL
7	Upper Gage Avenue - EXIT	-10	15-Sep-17	27.4	29.5	ARL
13	Upper Red Hill Valley Parkway - EXIT	-1	28-Aug-17	20.4	20.8	Tri-Chord
40	Strathearne Ave./Parkdale Ave. - EXIT	0	31-Aug-17	5.2	10.2	Non Std. Cantilever
2	Upper Wentworth St - EXIT	23	15-Sep-17	24.4	25.6	ARL
3	Upper James Street - EXIT	26	15-Sep-17	22.9	28.4	ARL
10	Garth Street - EXIT	27	06-Sep-17	24.4	29	ARL
5	Upper Gage Avenue - EXIT	29	06-Sep-17	27.4	30.5	ARL
8	Upper Wentworth St. - EXIT	29	06-Sep-17	27.4	30.7	ARL
16	Upper Red Hill & Mud Street - EXIT	45	28-Aug-17	28.5	27.8	Tri-Chord
1	Upper James Street - Exit	49	06-Sep-17	27.4	27.9	ARL
39	Strathearne Ave./Parkdale Ave. - ADVANCED	50	31-Aug-17	7.2	8.9	Non Std. Cantilever
31	Queenston Road - EXIT	50	28-Aug-17	28.4	23.3	Tri-Chord
19	Greenhille Avenue - EXIT	50	28-Aug-17	26.5	26	Tri-Chord
20	Upper Red Hill Valley Pkwy - EXIT	50	28-Aug-17	29.6	18.2	Tri-Chord
18	King Street - EXIT	50	28-Aug-17	28.4	26.6	Tri-Chord
11	Golf Links/Mohawk Rd - EXIT	60	06-Sep-17	29.0	30.5	ARL
9	Mohawk & Golf Links Rd - EXIT	62	06-Sep-17	27.4	29.6	ARL
43	Nikola Tesla Boulevard - EXIT	81	13-Oct-17	7.2	4.7	Non Std. Cantilever
32	Rousseaux Street - EXIT	90	29-Aug-17	34.6	25.2	Tri-Chord
25	Queenston Road - EXIT	90	29-Aug-17	28.4	22.5	Tri-Chord
44	Upper James St. & West 5th St. - SPLIT	94	13-Oct-17	18.0	3.8	Monotube

Structural Rating

Site Number	Structure Name	Structural Rating	Date of Inspection	Span	Total Sign Area	Structure Type
45	Upper James St. & West 5th St. - ADVANCED	94	13-Oct-17	17.3	8.8	Monotube
14	Greenhill Avenue - EXIT	95	29-Aug-17	26.1	21.1	Tri-Chord
15	King Street - EXIT	95	29-Aug-17	26.4	23.7	Tri-Chord
4	Garth Street - EXIT	96	06-Sep-17	25.9	21	ARL
17	Dartnall Road - EXIT	99	28-Aug-17	27.9	27.8	Tri-Chord
12	Upper Red Hill, Mud Street - EXIT	99	28-Aug-17	26.2	27.3	Tri-Chord
22	403 Brantford, 403 Toronto Split - ADVANCED	99	29-Aug-17	20.2	36.7	Tri-Chord
21	Lincoln M. Alexander Parkway - EXIT	100	28-Aug-17	16.1	20	Tri-Chord
26	Barton Street - EXIT	100	29-Aug-17	27.6	18.2	Tri-Chord
27	QEW Toronto, QEW Niagara, Split - ADVANCED	100	28-Aug-17	19.1	23.4	Tri-Chord
28	QEW Toronto, QEW Niagara - SPLIT	100	28-Aug-17	24.8	31.4	Tri-Chord
29	Red Hill Valley Parkway - EXIT	100	28-Aug-17	21.8	34.3	Tri-Chord
30	Barton Street - EXIT	100	28-Aug-17	29.1	23.7	Tri-Chord
33	Woodward Avenue - EXIT	100	29-Aug-17	19.2	22.2	Tri-Chord
34	QEW, Red Hill Parkway - SPLIT	100	13-Oct-17	21.6	31.3	Tri-Chord
35	QEW Toronto, QEW Niagara, Split - EXIT	100	29-Aug-17	18.2	20	Tri-Chord
23	Rousseaux Street - EXIT	100	29-Aug-17	6.0	10.4	Cantilever Class 2
38	Nikola Tesla Blvd - On Ramp	100	31-Aug-17	4.7	2.9	Non Std. Cantilever
42	Hamilton Ave. Local Access - EXIT	100	13-Oct-17	5.0	5.6	Non Std. Cantilever
41	DMS - South of Woodward Avenue	100	31-Aug-17	20.2	40.2	Walk-in VMS
24	403 Brantford, 403 Toronto Split - EXIT	100	29-Aug-17	26.1	28.4	Tri-Chord