



City of Hamilton

ADVISORY COMMITTEE FOR PERSONS WITH DISABILITIES REVISED

Meeting #: 22-007
Date: June 14, 2022
Time: 4:00 p.m.
Location: Room 264, 2nd Floor, City Hall
(hybrid) (RM)
71 Main Street West

Carrie McIntosh, Legislative Coordinator (905) 546-2424 ext.2729

Pages

1. CEREMONIAL ACTIVITIES

2. APPROVAL OF AGENDA

(Added Items, if applicable, will be noted with *)

3. DECLARATIONS OF INTEREST

4. APPROVAL OF MINUTES OF PREVIOUS MEETING

4.1. May 24, 2022

5

5. COMMUNICATIONS

6. DELEGATION REQUESTS

7. CONSENT ITEMS

7.1. Built Environment Working Group Update (no copy)

7.2.	Housing Issues Working Group Update	
a.	Housing Issues Working Group Meeting Notes - April 19, 2022	27
7.3.	Outreach Working Group Update	
a.	Outreach Working Group, Accessibility Fair Update, May 2022	39
b.	Outreach Working Group Meeting Notes - May 17, 2022	41
c.	Outreach Working Group Meeting Notes - June 1, 2022	43
7.4.	Transportation Working Group Update (no copy)	
7.5.	Strategic Planning Working Group Update (no copy)	
7.6.	Accessible Open Spaces and Parklands Working Group	
a.	Accessible Open Spaces and Parklands Working Group, Draft Terms of Reference	45
*b.	Accessible Open Spaces and Parklands Working Group Meeting Notes - May 25, 2022	51
8.	PRESENTATIONS	
8.1.	Presentation by Rich Padulo, Founder of Treat Accessibly respecting the Treat Accessibly Campaign	55
8.2.	Presentation by Alison Carlyle, Project Manager - Sustainable Mobility, respecting the Ontario Cargo E-Bike Pilot Program	75

- *8.3. Presentation by Andrea McDonald, Senior Project Works Manager, Public Works respecting the Location of a Wheelchair Swing in William Connell Park 91

9. PUBLIC HEARINGS / DELEGATIONS

10. DISCUSSION ITEMS

11. MOTIONS

- 11.1. Operation of Vehicles in Public Parks and Green Spaces 111

12. NOTICES OF MOTION

13. GENERAL INFORMATION / OTHER BUSINESS

- 13.1. Accessibility Complaints to the City of Hamilton (no copy)

- 13.2. Accessibility for Ontarians with Disabilities Act, 2005 (AODA) Update (no copy)

- 13.3. Presenters List for the Advisory Committee for Persons with Disabilities 115

- 13.4. Virtual Meetings for ACPD Working Groups (no copy)

14. PRIVATE AND CONFIDENTIAL

15. ADJOURNMENT



Hamilton

**ADVISORY COMMITTEE FOR PERSONS WITH
DISABILITIES**

MINUTES 22-006

4:00 p.m.

Tuesday, May 24, 2022

**Due to COVID-19 and the Closure of City Hall,
this meeting was held virtually.**

Present: A. Mallett (Chair), J. Kemp (Vice-Chair)
S. Aaron, J. Cardno, L. Dingman, A. Frisina,
L. Janosi, P. Kilburn, T. Manzuk, C. McBride,
M. McNeil, K. Nolan, T. Nolan

Absent

with Regrets: Mayor F. Eisenberger, P. Cameron,
M. Dent, T. Murphy, R. Semkow

Chair Mallett called the meeting to order and recognized that the Committee is meeting on the traditional territories of the Erie, Neutral, HuronWendat, Haudenosaunee and Mississaugas. This land is covered by the Dish with One Spoon Wampum Belt Covenant, which was an agreement between the Haudenosaunee and Anishinaabek to share and care for the resources around the Great Lakes. It was

further acknowledged that this land is covered by the Between the Lakes Purchase, 1792, between the Crown and the Mississaugas of the Credit First Nation. The City of Hamilton is home to many Indigenous people from across Turtle Island (North America) and it was recognized that we must do more to learn about the rich history of this land so that we can better understand our roles as residents, neighbours, partners and caretakers.

THE FOLLOWING ITEMS WERE REFERRED TO THE GENERAL ISSUES COMMITTEE FOR CONSIDERATION:

- 1. Resignation of Paula Kilburn from the Outreach Working Group of the Advisory Committee for Persons with Disabilities (Item 7.3)**

(Kilburn/Kemp)

That the resignation of Paula Kilburn from the Outreach Working Group of the Advisory Committee for Persons with Disabilities, be received.

CARRIED

- 2. Resignation of Kim Nolan from the Transportation Working Group of the Advisory Committee for Persons with Disabilities (Item 7.4)**

(K. Nolan/Aaron)

That the resignation of Kim Nolan from the Transportation Working Group of the Advisory Committee for Persons with Disabilities, be received.

CARRIED

3. Resignation of Paula Kilburn from the Strategic Planning Working Group of the Advisory Committee for Persons with Disabilities (Item 7.5)

(Kilburn/McNeil)

That the resignation of Paula Kilburn from the Strategic Planning Working Group of the Advisory Committee for Persons with Disabilities, be received.

CARRIED

4. Reimbursement for the Purchase of Plants as Get-Well Gifts (Item 11.1)

(Mallett/Kilburn)

That reimbursement to Aznive Mallett, in the amount of \$37.26, including HST, for the purchase of plants from House of Flowers in Ancaster as get-well gifts for two members of the Advisory Committee for Persons with Disabilities, be approved.

CARRIED

(Kilburn/Kemp)

That a plant be purchased for Patty Cameron on behalf of the Advisory Committee for Persons with Disabilities to express the Committee's condolences on her loss.

CARRIED

5. Policies and Procedures to Rescue and Safely Transport Stranded Pedestrians and their Mobility Devices (Item 11.2)

(Kilburn/Kemp)

WHEREAS, there have been an alarming increase in encounters between pedestrians and vehicles in recent months;

WHEREAS, persons with disabilities, especially those who use mobility devices, are particularly vulnerable as pedestrians;

WHEREAS, persons who use mobility devices are susceptible to having their devices malfunction, stranding them in precarious traffic situations; and

WHEREAS, the Advisory Committee for Persons with Disability (ACPD), have advised stakeholders including the Police Service, Fire Department, Paramedic Service, Hamilton Street Railway (HSR), Disabled and Aged Regional Transportation Service (DARTS), Taxicab Companies and Mobility Device Repair Contractors of the need for a coordinated rescue plan in the City of Hamilton for persons who experience an incapacitated mobility device.

THEREFORE, BE IT RESOLVED:

That staff be directed to investigate developing policies and procedures to rescue and safely

transport stranded pedestrians and their mobility devices to an appropriate secure location.

CARRIED

**6. Advisory Committee for Persons with Disabilities
Guidance to Hamilton BIA Communities on How
to Make Outdoor Dining Locations Fully
Accessible (Item 11.3) (REVISED)**

(T. Nolan/Kilburn)

WHEREAS, Council approved the Permanent Program for Temporary (seasonal) Outdoor dining Patios in the City of Hamilton, effective in 2022;

WHEREAS, the Temporary Outdoor dining Patios Program was made permanent by City Council in spite of the concern of the Advisory Committee for Persons with Disabilities (ACPD) that there were no specific provisions or obligations for outdoor dining facilities to be accessible and no prohibition to occupying pedestrian pathways; and

WHEREAS, there are opportunities to help make outdoor dining facilities accessible through consultation with the ACPD and its Accessible Outdoor Spaces and Parklands Working Group.

THEREFORE, BE IT RESOLVED:

That the Advisory Committee for Persons with Disabilities (ACPD), in collaboration with the ACPD

Outreach Working Group, work with staff to develop print materials, ***to come back to ACPD for approval***, for dissemination to Hamilton BIA communities to provide guidance on how to ensure outdoor dining is fully accessible including space, facilities, amenities and services; and

That the Hamilton BIA communities be advised that the ACPD and its Accessible Outdoor Spaces and Parklands Working Group are available to establishments that have outdoor dining facilities should they require advice or guidance on how to make their outdoor dining locations fully accessible including their space, facilities, amenities and services.

CARRIED

7. Correspondence to the General Issues Committee Respecting Homeless Encampments (Item 11.4)

(Cardno/Kemp)

That the correspondence to the General Issues Committee from the Advisory Committee for Persons with Disabilities respecting Homeless Encampments attached as Appendix "A", be approved.

CARRIED

8. Invitation to Dr. Lovaye Kajiura, McMaster IMPACT Initiative, to Attend a Future Meeting of the Advisory Committee for Persons with Disabilities (Item 11.5)

(Mallett/Kilburn)

WHEREAS, the McMaster IMPACT Initiative is an interdisciplinary collaboration that engages students and volunteer clients in a learning process whereby students come together to understand, appreciate and address challenges experienced by our aging population and people living with disabilities; and

WHEREAS, Dr. Lovaye Kajiura is one of the co-leaders of the McMaster IMPACT Initiative.

THEREFORE, BE IT RESOLVED:

That Dr. Lovaye Kajiura be invited to attend a future meeting of the Advisory Committee for Persons with Disabilities to present respecting the McMaster IMPACT Initiative.

CARRIED

9. Invitation to the Director of Transit, City of Hamilton, to Attend a Future Meeting of the Advisory Committee for Persons with Disabilities (Item 11.6) (REVISED)

(Mallett/T. Nolan)

WHEREAS, the Advisory Committee for Persons with Disabilities will benefit from meeting with the City of Hamilton's Director of Transit to discuss topics of interest to the Advisory Committee for Persons with Disabilities related to Transit Services;

THEREFORE, BE IT RESOLVED:

That the City of Hamilton's Director of Transit be invited to attend a future *regular or special* meeting of the Advisory Committee for Persons with Disabilities to discuss topics of interest to the Committee related to Transit Services.

FOR INFORMATION:

(a) CHANGES TO THE AGENDA (Item 2)

The Committee Clerk advised of the following changes to the agenda:

5. COMMUNICATIONS

- 5.1 Correspondence from Andrea Michaluk respecting deafness and discrimination
- 5.2 Correspondence from Sophie Geffros respecting Resignation from the Advisory Committee for Persons with Disabilities

12. NOTICES OF MOTION

- 12.1 Operation of Vehicles in Public Parks and Green Spaces

(Kilburn/McNeil)

That the agenda for the May 24, 2022 meeting of the Advisory Committee for Persons with Disabilities, be approved, as amended.

CARRIED

(b) DECLARATIONS OF INTEREST (Item 3)

There were no declarations of interest.

(c) APPROVAL OF MINUTES (Item 4)

(i) April 12, 2022 (Item 4.1)

(Kemp/McNeil)

That the minutes of the April 12, 2022 meeting of the Advisory Committee for Persons with Disabilities, be approved, as presented.

CARRIED

(d) COMMUNICATIONS (Item 5)

**(i) Correspondence from Andrea Michaluk
respecting deafness and discrimination (Item
5.1)**

(Janosi/Dingman)

That the correspondence from Andrea Michaluk respecting deafness and discrimination, be received.

(T. Nolan/K. Nolan)

That the motion be ***amended*** by adding recommendation (b), to read as follows:

(b) That staff be directed to work with Andrea Michaluk to determine what the City can undertake to address her concerns and report back to the Advisory Committee for Persons with Disabilities.

CARRIED

Main Motion, ***as Amended***, to read as follows:

- (a) That the correspondence from Andrea Michaluk respecting deafness and discrimination, be received; and
- (b) That staff be directed to work with Andrea Michaluk to determine what the City can undertake to address her concerns and report back to the Advisory Committee for Persons with Disabilities.***

Main Motion, As Amended, CARRIED

**(ii) Correspondence from Sophie Geffros
respecting Resignation from the Advisory
Committee for Persons with Disabilities (Item
5.2)**

(McNeil/Kemp)

That the correspondence from Sophie Geffros
respecting resignation from the Advisory
Committee for Persons with Disabilities, be
received.

CARRIED

(Kilburn/Kemp)

That, having received the resignation of Sophie
Geffros from the Advisory Committee for Persons
with Disabilities, the membership number of the
Committee be adjusted accordingly to obtain
quorum.

CARRIED

(T. Nolan/K. Nolan)

That staff be directed to send a letter to Sophie
Geffros to thank her for her time volunteering with
the Advisory Committee for Persons with
Disabilities and to wish her well in the future.

CARRIED

(e) CONSENT ITEMS (Item 7)

**(i) Built Environment Working Group Update
(Item 7.1)**

(a) Built Environment Working Group Meeting Notes:

(1) February 2, 2022 (Item 7.1 (a))

(2) April 5, 2022 (Item 7.1 (b))

(Kilburn/Dingman)

That the Built Environment Working Group Meeting Notes of February 2, 2022 and April 5, 2022, be received.

CARRIED

(ii) Housing Issues Working Group Update (Item 7.2)

(1) Housing Issues Working Group Meeting Notes – March 15, 2022 (Item 7.2 (a))

(McNeil/Janosi)

That the Housing Issues Working Group Meeting Notes of March 15, 2022, be received.

CARRIED

(iii) Outreach Working Group Update (Item 7.3)

(1) Update respecting the Ability First Accessibility Event – October 5, 2022 (Item 7.3 (a))

(Dingman/Aaron)

That the update respecting the Ability First Accessibility Event – October 5, 2022, from the Outreach Working Group, be received.

CARRIED

(iv) Transportation Working Group Update (Item 7.4)

(1) Transportation Working Group Meeting Notes – April 26, 2022 (Item 7.4 (a))

(McNeil/Kilburn)

That the Transportation Working Group Meeting Notes of April 26, 2022, be received.

CARRIED

(v) Strategic Planning Working Group Update (Item 7.5)

(a) Strategic Planning Working Group Meeting Notes:

(1) February 10, 2022 (Item 7.5 (a))

(2) March 3, 2022 (Item 7.5 (b))

(3) March 16, 2022 (Item 7.5 (c))

(4) April 7, 2022 (Item 7.5 (d))

(Dingman/Frisina)

That the Strategic Planning Working Group Meeting Notes of February 10, 2022, March 3, 2022, March 16, 2022 and April 7, 2022, be received.

CARRIED

(vi) Accessible Open Spaces and Parklands Working Group Update (Item 7.6)

(a) Accessible Open Spaces and Parklands Working Group Meeting Notes:

(1) February 23, 2022 (Item 7.6 (a))

(2) March 23, 2022 (Item 7.6) (b))

(T. Nolan/McNeil)

That the Accessible Open Spaces and Parklands Working Group Meeting Notes of February 23, 2022 and March 23, 2022, be received.

CARRIED

(3) April 27, 2022 (Item 7.6) (c))

(T. Nolan/K. Nolan)

That the Accessible Open Spaces and Parklands Working Group Meeting Notes of April 27, 2022, be received.

CARRIED

(f) PRESENTATIONS (Item 8)

(i) Presentation by Sherry Caldwell, Ontario Disability Coalition (Item 8.1)

Sherry Caldwell, Ontario Disability Coalition provided the Committee with a presentation respecting the Ontario Disability Coalition, with aid of a PowerPoint presentation.

(Frinsina/Dingman)

That the presentation by Sherry Caldwell, Ontario Disability Coalition respecting the Ontario Disability Coalition, be received.

CARRIED

(g) MOTIONS (Item 11)

(i) Reimbursement for the Purchase of Plants as Get-Well Gifts (Item 11.1)

A. Mallett relinquished the Chair to J. Kemp in order to introduce a Motion respecting reimbursement for the purchase of plants as get-well gifts.

For disposition of this matter, refer to Item 4.

A. Mallett assumed the Chair.

(ii) Invitation to Dr. Lovaye Kajiura, McMaster IMPACT Initiative, to Attend a Future Meeting of the Advisory Committee for Persons with Disabilities (Item 11.5)

A. Mallett relinquished the Chair to J. Kemp in order to introduce a Motion respecting an invitation to Dr. Lovaye Kajiura, McMaster IMPACT Initiative, to attend a future meeting of the Advisory Committee for Persons with Disabilities.

For disposition of this matter, refer to Item 8.

(iii) Invitation to the Director of Transit, City of Hamilton, to Attend a Future Meeting of the Advisory Committee for Persons with Disabilities (Item 11.6)

A. Mallett introduced a Motion respecting an invitation to the Director of Transit, City of Hamilton, to Attend a Future Meeting of the Advisory Committee for Persons with Disabilities.

For disposition of this matter, refer to Item 9.

A. Mallett assumed the Chair.

(h) NOTICES OF MOTION (Item 12)

(i) Operation of Vehicles in Public Parks and Green Spaces (Item 12.1)

J. Cardno introduced the following Notice of Motion:

WHEREAS, parks and green spaces have been recognized as valuable, contributing to the good health of City residents and as a result of the COVID-19 Pandemic, use of these spaces has increased;

WHEREAS, any vehicular traffic moving through a park not only reduces such benefits but presents a threat that is unexpected in a park, particularly for those with disabilities and using mobility devices;

WHEREAS, invisible disabilities are not easily identified and operators of vehicles may not be sensitive to related fear and anxiety that results when an unexpected vehicle suddenly comes near;

WHEREAS, the public in vehicles may mistake hard surface paths as roadways because of other vehicles or evidence of vehicle use and will enter and travel at speed presenting a very real danger to park users and especially those unable to

move quickly out of the way due to mobility or disability limitations; and

WHEREAS, City staff should receive sensitivity and awareness training regarding those with disabilities as part of customer service when dealing with the public, particularly for new and seasonal staff.

THEREFORE, BE IT RESOLVED:

1. That staff be directed to review policies and procedures regarding vehicle traffic and presence of vehicles throughout parks and green spaces and recommend actions to keep the presence and operation of vehicles in parks and green spaces to a minimum, as follows:
 - (i) Ensure the use of public roads rather than park pathways unless it is an emergency; and
 - (ii) Ensure that pathways are not easily accessible to vehicles and that the use of barriers to limit vehicles does not restrict or inhibit the use of mobility devices.
2. That staff be directed to provide regular sensitivity and awareness training for staff as

part of customer service when dealing with the public, including new and seasonal staff, to include awareness of the benefits parks and green spaces offer and ways to decrease any activity that interferes with those benefits.

(i) GENERAL ISSUES / OTHER BUSINESS (Item 13)

(i) Accessibility Complaints to the City of Hamilton (Item 13.1)

No update.

(ii) *Accessibility for Ontarians with Disabilities Act, 2005 (AODA) Update (Item 13.2)*

No update.

(iii) Presenters List for the Advisory Committee for Persons with Disabilities (Item 13.3)

(a) Invitation to The Honourable David Onley, former Lieutenant Governor of Ontario

(Kilburn/McNeil)

That the Advisory Committee for Persons with Disabilities request that the City fund the \$5,000 plus HST speaking engagement fee for The Honourable David Onley, former Lieutenant Governor of Ontario.

DEFEATED

**(b) Invitation to Sherry Caldwell of the
Ontario Disability Coalition**

(McNeil/Kemp)

- (a) That the Invitation to Sherry Caldwell of the Ontario Disability Coalition be considered complete and be removed from the Speakers List as this was addressed as Item 8.1 at today's meeting; and
- (b) That the updates to the Speaker's List, be received.

CARRIED

**(iv) Donation in Memory of Christopher Cutler
(Item 13.4)**

This Item was referred to the Strategic Planning Working Group.

(j) ADJOURNMENT (Item 15)

(Kemp/Cardno)

That there being no further business, the Advisory Committee for Persons with Disabilities, be adjourned at 6:13 p.m.

CARRIED

Respectfully submitted,

Aznive Mallett, Chair
Advisory Committee for
Persons with Disabilities

Carrie McIntosh
Legislative Coordinator
Office of the City Clerk

Housing Working Group Meeting Notes

April 19th, 2022

Virtual WebEx Meeting

10:00AM – 12:00PM

Those in Attendance: James Kemp, Tom Manzuk, Paula Kilburn, Lance Dingman, Jayne Cardno

Also in Attendance: Jen Chivers, Laura Cattari, Tom Cooper, Jessica Bowen

Those Absent: Sophie Geffros, Robert Semkow

1. Welcome and Introductions
2. Approval of April 19th Agenda: Agenda was approved.
3. Approval of Mar 15th Meeting Notes: Meeting notes were not ready for distribution. Will distribute as soon as ready.
4. RFPR Tom Cooper regarding HATS (Hamilton Alliance for Tiny Shelters): Due to an unprecedented homelessness problem caused by several factors; the pandemic, stagnant social assistance programs, rapid inflation, econovictions, renovictions, poor mental health and addiction

supports, restrictive shelters and RCF residences and a rapidly dwindling housing supply to name just a few.

This has forced people to think outside the box and the HATS program is doing just that. They consist of tiny cabins that are meant to house those that don't fit into the existing programs. They are 8' x 10' cabins or sheds. They have no plumbing, but are heated with electricity and hopefully wifi as well. They all have their own locks and each tenant will be given the only key, giving them a sense of ownership. Not what one would consider luxurious. There is a portable washroom on site with a working shower.

The nearest municipality to attempt a program like this is in Kitchener Waterloo and they have had great success. Their program has been in operation for over three years. The recent encampment by-laws have forced those that live on the fringes to become even more unstable. There are dozens of examples of this sort of program across North America.

For some, there are no options for them in the shelters or RCFs. This can affect couples, people

that cannot live without the support of their pets, people with addiction issues, behavioural issues, mental and emotional disabilities and many more reasons.

A large percentage of the people using some form of homeless support are disabled. HATS is considering asking ODSP recipients to allocate their shelter portion to them in an effort to reduce costs. This payment would be voluntary however, because they do not want to perpetuate homelessness.

The tiny cabins can be rapidly set up as soon as an appropriate location can be found.

They currently have a demonstration cabin on James St. N. and welcome citizens of Hamilton to take a look and get accustomed to the idea.

Paula asked if couples would be given their own cabin?

Tom C. responded; no there is a restriction on the size of the unit. Any larger than 8 x 10 would require permits, more approval, and passing the OBC before it could be implemented. More likely each person would be assigned their own space and they could share it accordingly.

Paula asked; what would it cost for an individual to live in one?

Tom C. replied; Fundraising should take care of a majority of costs including On-Site supervision. Any rents will be voluntary.

Jayne asked; how do we change attitudes about homelessness?

Tom C. responded; it is difficult to make people aware of the institutionalization of poverty and homelessness. There was a time in the 80's that people thought food banks would only be a temporary solution, but here we are 40 years later and food banks can no longer keep up with demand. Local advocacy and awareness is crucial.

Jayne raised the point that ODSP would cut the shelter portion of a person's monthly disability check if they were given a free apartment.

Lance asked: how many people would the on-site plumbing system be able to handle?

Tom C. responded that the first site will support ten people. If it becomes a more permanent placement, they will connect it to the municipal water and plumbing. The washroom unit will also supply the water for the site.

Lance asked if this program was similar to the tiny homes project?

Tom C. responded that the tiny homes project consists of complete mini homes. They have

plumbing and kitchen facilities and pass OBC. HATS could be better described as portable sheds. Tom M. asked if the shelters would be accessible if the person needed it and if they could charge mobility devices?

Tom C. explained that they would be able to build ramps as needed and put in other accessibility features, like grab bars to suit the individual's needs. They would have electricity and be able to charge equipment.

The Chair pointed out that while the shelters may not seem like what one would call luxurious, the fact that they provide privacy is a luxury that is not afforded to people in either the shelters or the RCFs.

The Chair also raised the issue that a lot of homeless people are homeless because the system is too rigid for them, like someone who's only support is their cat. Should we force them to decide between either, a place to sleep safely or their only friend in the world? People would usually prefer to live on the street than to give up those last few freedoms.

The Chair raised the issue of the shelters being considered temporary. If this program serves as an effective alternative to the systems already in place, especially for those that don't fit the current system,

should we not explore the more permanent options? The chair also suggested that while these shelters are very movable, that we should be striving to keep them in the same location to give the residents some sense of stability. They are forced to move often enough, should we not try to show them community? The residents around encampments like to raise the issue of the filth and poor conditions of them, but if those residents welcomed a community of these homes into their area, they could lead by example and show what community spirit is all about.

Jayne asked if there would be any arts program funding for the shelter residents?

Tom C. responded; yes, we received a directed donation specifically for that purpose and we will look at ways to bring it to the shelter residents.

Paula asked where would these shelters be situated?

Tom C. replied, we initially had an offer to set up at the John A. MacDonald site, but there was a flood in the gym and the Board of Education is being forced to tear down the school early. We surveyed forty-five homeless individuals and were surprised to learn that they would all like to be in a location close to downtown, but not in downtown. They would like to be able to easily access the services

of downtown, but want to live away from the influences that contributed to their continued homelessness. We are looking for a suitable location away from the core now. We will start with ten and hope to increase to twenty. Not all communities are against this program, but location is going to be crucial. The first site will serve as an example for more.

The Chair asked; how can the Housing Working Group and the ACPD in general help you get this program moving forward.

Tom C. Replied; the best way you could support us is to send a letter of support for the project to City Council.

5. RFPR Jen Chivers regarding RCFs: Jen began by stating that the best way we can all make substantive changes to the system is to join forces with other like-minded groups, especially with those that have the funding and infrastructure in place already.

Her experiences on the Greater Hamilton Health Network's RCF Steering Committee have made great strides in improving the health outcomes of those living in RCFs. It is relatively new and residents may not see the changes yet, but they

have made great strides by using the work other groups have done before and going forward as opposed to reinventing the wheel every time. The purpose is to improve health care in partnership with over thirty organizations across Ontario to improve Ontarians quality of life. They are only running pilots at four RCF sites but results have been positive so far.

Jen mentioned that there is new work being done on connecting residents of RCFs to the internet or WiFi. It has been deemed a vital need and will be reviewed as such.

There is some changes in perspective regarding how we approach substance abuse issues and how we can help not only the users, but the residents around them.

We had a Mac Student perform an environmental scan of RCFs. It was a look at a frozen slice of time. This gave us a chance to see what areas need the most attention.

There are two different homeless numbers. One represents all the people in some form of homelessness support and the second was the number physically living on the street.

6. RFPR Laura Cattari regarding Social Programming: Laura began her presentation by giving some

history. Institutional beds were closed some time ago and a lot of the people that were turned loose suffer from mental disabilities of some form or another. These are people that the system doesn't know how to handle. Politicians certainly misunderstand their needs and adequate, safe housing isn't even available for them. The recent Federal budget made little mention of the housing issue at this level and will not make a serious impact on the problem. For example, the Housing Stability Benefit. They have announced a \$500 top up in order to alleviate some of people housing needs. This is indicative of government not even understanding who this benefit is supposed to help and what problems it will not alleviate. Income security is an integral part of the housing crisis and nothing will improve until it is dealt with on that level.

The previous Liberal government was looking at unifying the ODSP payment but was unable to implement it before they were out of power. This would have eliminated the shelter and support portions so that people could allocate their own funds as needed. The social assistance benefit is not adequate as it is and this government continues to find ways of clawing back support.

The RFPR fully supports basic income. At the start of the pandemic, the Federal government decided that a person requires \$2000 per month in order to have a living wage. ODSP still pays out \$1100 per month, this is mandating deep poverty. We support a person's autonomy to make their own financial decisions. We think the disabled should be able to get this support without jumping through endless hoops and following strict rules. ODSP has been frozen for more than a decade. It never really recovered from the Harris era cuts of more than 20%.

This government has avoided the issue for the past four years. They are only concerned about making people work. After the election, if they remain in power, we will probably see them change the policies in the same fashion as they have changed Ontario Works and force people to work despite their abilities.

The Federal government announced an extra support benefit for working age people with disabilities, but they gave themselves three years to consult about it before they needed to act. The most recent budget only mentioned finding us employment.

There is an active effort to silence or hide the severity of these issues. There seems to be an

opinion with those in power that we don't actually need help and we only want to freeload on the public dime.

Great changes have been made to the system under the radar during the unprecedented power the Government has had during the pandemic. They have made it difficult to advocate for those in the most need.

In order to get the most benefit, it is important to join forces with other like-minded groups. Income is the most important social determinant of health.

Tom C. mentioned that they are part of a larger group called Just Recovery Hamilton and mentioned that they will be holding a number of round tables leading up to the election. Raising issues has been difficult when 80% of media coverage is COVID related.

Electronic voting improves voter turnout by 97%. It is important to adopt new forms of voting because it improves turnout and engagement across the board.

There is a disconnection when speaking to those in power. We don't seem to be speaking the same language and we need to find a way of making them understand the problem, let alone fix them.

The lack of extra support for people on OW and ODSP during the pandemic highlights this fact.

When we told people in government that they needed extra support, they responded that people on social assistance have no need for anything extra and that the pandemic doesn't affect them in any way financially.

7. Adjournment.

Outreach Working Group's May Update for the ACPD's 2022 Accessibility Fair

I am in contact with staff regarding getting the appropriate permits and permissions to have an event in City Hall, in the Forecourt and behind City Hall. We will require a parking permit out back for the HSR/DARTS vehicles. I have started filling out the food service paperwork to allow for a food vendor. I have described, in detail, the events that we want to hold in the Forecourt and should get an answer soon on what is required there and the costs involved. So far, there is no selling of products even for fundraising purposes in the Forecourt, but should have more information there soon.

I have also been in communication with the City's Communication Department regarding setting up a webpage. After consultation and due to the fact that we are going to be using the Mac students to help us, it was recommended that we host the webpage separately and then have the City host the links. I will try to find a free webpage hosting service, but we may have to pay for one for the next four months. We will also produce banner ads for the homepage.

Presenters: I have no update here, we need to come up with a list and send out invites.

Food Service: No update yet, will have more soon.

Activities: Potential activities already in rough planning stages are the obstacle courses: White Cane, Wheelchair, Walker. One of them will involve the transportation services out back. Product demonstrations/ care demonstrations; Still have to reach out to mobility vendors and see what participation we can expect. Mobility Device “Car Wash”. This is on our maybe pile only because it will be very labour intensive.

Stakeholder/Informational Tables: We need to make a list and make contact with the various organizations around the city.

I have reached out to Lovaye this week so we can discuss what volunteer labour force we may have and when they are all available.

Outreach Working Group Meeting Notes

May 17th, 2022

Virtual WebEx Meeting

4:00PM - 6:00PM

Those in Attendance: Anthony Frisina, Aznive Mallet,
James Kemp

Also In Attendance: Jessica Bowen

Those Absent: Tom Manzuk, Paula Kilburn, Jayne
Cardno, Patty Cameron

1. Welcome and Introductions
2. Approval of May 17th Agenda: There being only two members able to stay, we had a brief discussion and adjourned early.
3. Other Business: We had a brief discussion about transcription programs with Jessica. She is unaware of any software in the City's package, but is willing to explore trial software to find the best options.
4. Adjournment at 4:10PM

Outreach Working Group Meeting Notes

June 1st, 2022

Virtual WebEx Meeting

4:00PM – 6:00PM

Those in Attendance: James Kemp, Patty Cameron

Also in Attendance: Sunil Angrish

Those Absent: Tom Manzuk, Anthony Frisina, Jayne Cardno, Aznive Mallett

1. Welcome and Introductions

2. Approval of June 1st Agenda: As there were only two of us in attendance, we had an informal discussion. James gave Patty an update on the plans for the event.

3. Accessibility Fair Planning: Patty described her Steel City Rollers square dancing demonstration. 8 dancers will provide a 30 minute demonstration followed by an additional 30 minute group participation event. Patty will look into having Mission Services provide the food service and will get information soon. Patty will also discuss the wheelchair portion of the obstacle course with Spinal Cord Injury. The “Chair Wash” consists of a wipe down and possible tune-up. James will reach

out to Levi regarding a hearing impairment/lip-reading demonstration station. Banners will need to be ordered soon.

4. Adjournment: As no other member signed in by 4:40, we adjourned the meeting.

Accessible Open Spaces and Parklands Working Group
Terms of Reference (Working Group Guidelines)
Draft 2
March 23, 2022

Purpose

The Accessible Open Spaces and Parklands Working Group (OSPWG) supports the work of the City of Hamilton's Advisory Committee for Persons with Disabilities (ACPD) by providing guidance to the Committee as it advises City Council on matters of accessibility and compliance with the Accessibility for Ontarians with Disabilities Act. Specifically, the working group focuses on open spaces, parklands and all components or facilities contained therein not regulated by statute or addressed under other ACPD working groups, except where specified.

Scope

The OSPWG scope shall include, but not necessarily limited to:

- City owned or leased open spaces, parklands and facilities contained therein;
- Parks, sports parks and outdoor recreational areas including play areas and play area structures;
- Outdoor recreational pools, splash pads and other related water facilities;

- Trails;
- Golf Courses;
- Outdoor dining sites including dining which encroaches sidewalks;
- Any AODA regulation insufficient for which upgraded accessibility is deemed necessary by ACPD or City staff;
- Any other outdoor spaces not specifically cited herein or at the pleasure of the ACPD or City Council and staff.

Outdoor spaces NOT typically in scope include, and not necessarily limited to:

- Sidewalks;
- Parking lots;
- Roads and highways;
- New building construction and related site plans;
- Any AODA regulations deemed sufficient by ACPD or City staff.

Membership and Administrative Assistance

Members of ACPD as assigned to the working group by the ACPD.

Staff members as assigned by senior staff and management.

Members of any other City Committee as may be assigned by invitation of the ACPD.

Meeting agendas shall be prepared by the Working Group chair in consultation with working group members and City staff.

For purposes of taking notes of monthly meetings, maintenance and distribution thereof, this will be undertaken by staff.

Any proposed guidelines, standards or related designs shall be maintained by staff, converted to technical requirements and reported to City Council as appropriate by staff.

Any final report due to Council respecting any design guidelines or standards shall be reported to City Council by staff following endorsement of the full ACPD.

Meetings

Meetings shall be held the fourth Wednesday of each month from 1:30 p.m. – 3:30 p.m.

Meetings to be held at City Hall, when in person, or virtually via the City's supported virtual meeting platform.

City staff, those who support the work of the ACPD, shall make arrangements for any virtual meetings or arrange meeting space at City Hall whatever is appropriate month to month.

Activities

Advise staff with the design of any open space and parkland facilities which comprise any part of City owned or leased open spaces and parklands as may be necessary.

Advise on the development of a range of accessible standard features regularly incorporated as part of many, or most parks and open spaces for staff reference when designing new projects.

Respond to any questions or concerns regarding open spaces and parklands which may be raised by the ACPD

Respond to any questions or concerns raised by City Council or staff as they relate to open spaces and parklands.

Review, as requested by staff, open space design standards arising from the AODA to determine suitability or need for upgrade.

Review any current open spaces under design as requested by staff or as may be permissible under the AODA.

Make any recommendations to staff or City Council respecting open spaces and parklands as may be necessary from time to time, even where such recommendations may be controversial.

Communicate with ACPD for referral to City Council any concerns regarding perceived contravention of the AODA in the design of any open spaces or parklands.

Communicate with any other ACPD working group where clear overlap exists, or in response to inquiries for information.

OSPWG Notes
Wednesday, May 25, 2022
1:30 – 3:30 p.m.

Welcome and introductions

Present: Meghan, Paula, Mark, Aznive, Kim and Tim
Regrets: Tom
Absent: James

Welcome to Paula

Review and follow up from April 28, 2022 meeting

All good

Updates from May 24, 2022 ACPD meeting

No comments

Sidewalk dining tour with Rob Lalley May 26, 2022 11:00
a.m.

Invite to ACPD members to be sent via Carrie. Tour was mentioned to all ACPD members at the May 24, 2022 meeting. Purpose is to look at some dining sites along the

James St. North corridor re: accessibility to dining and sidewalk obstruction.

Discussions with consultant on outdoor dining guidelines

Tim spoke recently with Thea (company name?) re: information on their website re: outdoor dining accessibility. The website is often used as reference by municipalities. Thea agreed that the information on the site can be reviewed for update. Tim to send link to WG folks. Consultant agreed to update the site with input. Any input welcome from all.

Info re: outdoor dining

The brochure approved by ACPD and to be designed by Outreach should include general info and referral to ACPD. Photo on the front: Barrier to person with a disability photo. Consult with ACPD.

List of to do things or things to think about – minimums

Spreadsheet of Parklands and Open Spaces Structures

Led to discussion of swing surfaces underneath. Meghan indicated rubber surface is a good alternative to wood chips/mulch. Materials must consider for risk of injury in case of accident. In Many instances a combination of rubber and mulch/wood chips are used. Cost is an issue to

use the rubber surface. Parks can be selected on a case by case basis.

Led to discussion about consultation with ACPD on design and development including new and retrofit parks

Spreadsheet

Meghan will take a first attempt to populate the spreadsheet. All agreed that the design of the spreadsheet was acceptable to start.

Meghan has been speaking with Carrie about authority to make regulations. City has made barrier free design guidelines which may be the only option going forward. By regulation staff must comply first with code and AODA. May be a matter of language choice (regulation versus guideline) to create accessible spaces. In many instances park folks try to exceed code (e.g. 5% slope) but at times they can only meet code (8% slope).

Spreadsheet is okay by all and Meghan has already started to pull it together. Meghan will also work on it over the next couple weeks including populating the list

GAATES guidelines discussion

Lots of information there. Hope folks can take a look before next meeting. A lot of items for the spreadsheet will come from the GAATES document.

Other Business

Discussion about some items for accessible design such as distance between benches and picnic tables. All these things should make their way into a new document.

OT student

The idea of an OT student assisting with this work under the direct supervision of staff is a good one. Tim to reach out and feed back info to staff at the next meeting.

Next meeting June 22, 2022 1:30 – 3:30 p.m.

2021 Positive
Impact Report



Treat Accessibly

The Intergenerational Halloween Movement
Accelerating Accessible Awareness and Inclusion.

In 2022, we will work again with government, schools, communities, private sector and homeowners to grow the movement to make Halloween the first holiday, ever, to inspire *accessible inclusion for our children.*



[2021 Treat Accessibly Halloween Village](#)

Rich Padulo

- Proud Dad of Siena, the 10-year old winner of the The Rick Hansen Foundation Difference Maker Award for Ontario.
- Founder, Treat Accessibly® North America
- Appointee, Ontario Accessibility Advisory Standards Committee (1 of 13 private citizens)

What being part of the movement feels like Page 56 of 116

Our movement has directly benefited over 400,000 children with disabilities in Canada.
By mobilizing any homeowner across our country to champion them.



[Please](#)
[Click](#)
[to](#)
[Watch](#)



How It Started.

Like a lot Dads, I was putting Halloween pumpkins on our stairs, when I locked eyes with a little boy using a wheel chair across the street. I realized, in that moment, our front steps were a barrier to Trick-or-Treat at my home for that little boy.

Our daughter, Siena, and I created the sign, and the Treat Accessibly experience, that night so that little boy would know he's welcome at our home because his family would see the lawn sign.

Our attainable goal now, 400,000 homes with a sign, in Canada, by 2025.

One home for the 400,000 children with disabilities in Canada.

Our dream, to help Canada become the most accessible country in the world by rallying millions on Halloween to participate.



**The Padulo Family
Treat Accessibly Founders**

Help An Inclusive Future

22% of people in Canada and the U.S. identify with having a disability.

If you were to take every child in grade 1 in both countries, that's how many children identify with having a mobility, sensory or intellectual disability.

Our family keeps growing this intergenerational movement to make Halloween accessible for all children.

By making Trick-or-Treating inclusive we all help create a more accessible aware world in the future for all people with disabilities.



2017

Our family's first lawn sign at our home.

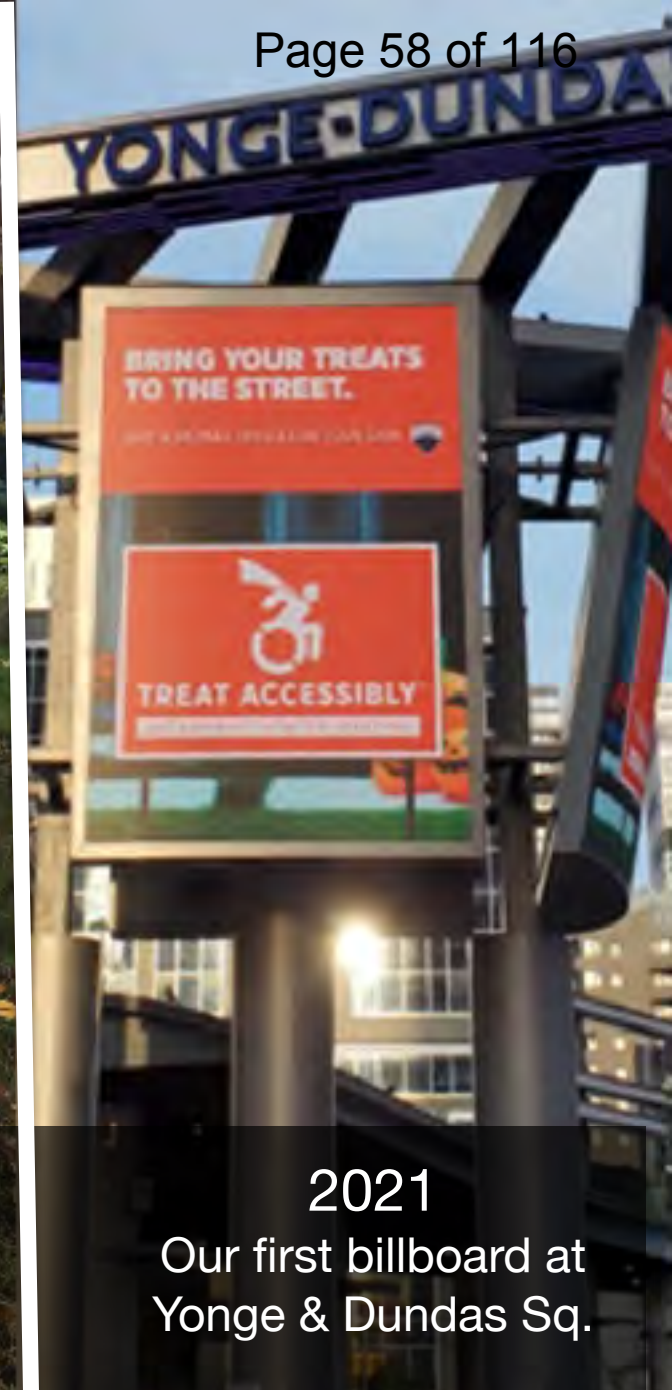

2021

Our first billboard at Yonge & Dundas Sq.

By 2021, 100,000 home owners had our lawn sign.

The press shared our story, generating 41 million earned media impressions, in 2021.

Combined with 2019, our family have generated over 80 million earned media impressions to date.

Add the public-generated social, lawn signs in neighbourhoods across the country (conservative est. 70 million in 2021) for 7 days+ leading to Halloween. Plus, millions in paid impressions by our partners RE/MAX Canada Agents, Canadian Tire and Kinder, through their respective paid media campaigns.

Made possible by cities and regions Social Support, Press Media Awareness and Distribution of FREE Lawns Signs at City Events, Libraries and City Halls and more.

Est. 2021 Total Impressions To Canadians:

166 million

Press Media 2021:
41 million

100k Lawn Signs 2021:
70 million

Partner Campaigns 2021:
30 million

Earned Social 2021:
20 million

Ont. Gov Channels 2021:
5 million



2021 & 2022 partner actions

As a grassroots, family-run, movement we have been joined by brand partners that share our desire to create more *accessibly inclusive* communities and build kinder societies for our kids to grow up in.



2021 Government & School Action Summary:

- Millions in earned media impressions via Government social channels and action.
- 124 schools successfully piloted a Treat Accessibly curriculum in class, created by the Rick Hansen Foundation.
- Governments and schools distributed our Treat Accessibly Lawn Signs featuring brand partner logos.
- Toronto joined multiple cities in passing a binding resolution to promote movement annually through their corporate communications (Vaughan, Brampton, Mississauga, Ajax, Hamilton, Oshawa)

See appendix for 2021 government and school action details

Governments are rooting for us.

How our grassroots movement is successfully rallying provinces, cities, regions and towns and why it's historically important.



Government Pilots

City of Vaughan passed a binding resolution to recognize Treat Accessibly and promote it via all communication channels annually.

Regions, cities and towns of Mississauga, Brampton, Hamilton, Vaughan, Ajax, Caledon, Peel, Laval, Surrey and New Glasgow **champion with School boards, socialize and/or distribute our lawn signage. Representing a combined population of close to 2 million people.**

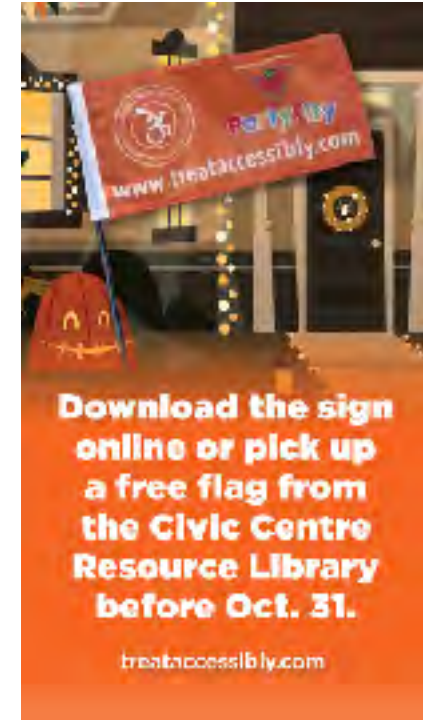

Historic and future significance

Gaining the support of partisan and non-partisan government to pass binding resolutions that are already been actioned creates a heightened level of credibility that becomes annualized and builds with time as the precedent of support permits us to expand across the country with the inclusion message and action.



Toronto is the first mega city to pass a binding resolution that will help us speed like discussions across Canada.



MM37.20	ACTION	Adopted		Ward: All
---------	--------	---------	--	-----------

Accessible Trick-or-Treating - Treat Accessibly Initiative - by Councillor Frances Nunziata, seconded by Councillor Kristyn Wong-Tam

City Council Decision

City Council on November 9, 10 and 12, 2021, adopted the following:

1. City Council direct Strategic Communications, on an annual basis, to promote awareness of the Treat Accessibly initiative, through the appropriate corporate communication outlets.
2. City Council direct that Motion MM37.20 be shared with Toronto’s Accessibility Advisory Committee, Ontario’s Minister for Seniors and Accessibility, and Members of Provincial Parliament and Members of Parliament whose ridings are located in the City of Toronto.

In 2022

Precedent to practice

Treat Accessibly, ahead of municipal elections in June ‘22, will mount a campaign with select cities in Vancouver, Edmonton, Calgary, Ottawa, Montreal and Halifax to gain awareness for the movement with hope the cities will pass similar resolutions in their cities.





2021 Partner Action Summary:

- 121 million+ impressions from tactical in-store, traditional and social campaigns and lawn signage on and leading to Halloween night.
- 41 million in tracked earned media generated by Treat Accessibly.
- 100,000 Treat Accessibly Lawn Signs in market to date.
- 1st Accessible Trick-or-Treating Neighbourhood - a very scalable event across Canada.



2022 Partner Action Plan Summary:

- 600k boxes of Kinder Halloween candy will include Treat Accessibly's story.
- RE/MAX agents and offices nationally will be providing signs.
- Canadian Tire will be championing Treat Accessibly Halloween Villages in up to 7 cities.
- Toyota head office will be delivering lawn signs to every member of the team and communicating it to their entire network.
- More brand partners are in talks to help share the story and champion the movement.

In 2022 - Kinder is all in by putting us on the box



Increasing investment
+40%

Influencers & Social Media

Increased investment



Shopper marketing

Key retailer (TBC)



Millions more impressions in 2022

Treat Accessibly will appear on 600,000 boxes of Halloween candy with a message taking up 1/3 of the box sharing our *accessible inclusion* message.

10,000 shelf wobblers will appear in grocery and drug stores across the country.

A heavy digital paid campaign will grow 40% with Influencers in every major market including Québec,

A shopper marketing campaign in a key retailer will boost the message to homeowners across Canada.

An army of community support - RE/MAX

How Corporate, Agents and RE/MAX offices got excited to accelerate accessibility in their communities



Social sharing and connecting with communities

Every RE/MAX Franchise across Ontario, Atlantic and Québec received and distributed signs produced by RE/MAX Corporate. Many agents and offices promoted it on social and had signs picked up from their offices, homes or dropped them off to Homeowners directly.

Touching response nationally

While the Western Canada RE/MAX didn't participate in 2021, their Agents across still got on board -coming to our site and printing their own signs.



City connections

The City of Brampton asked to distribute RE/MAX branded Treat Accessibly Lawn Signs. We only had 300 signs left to give them .

They have already asked for more in 2022.



Neighbourhoods asking for more.

Neighbourhoods across Canada reached out to local Agents for signs and created their own Treat Accessibly community events.



Driving community to RE/MAX.

Every piece in the media featured the Treat Accessibly / RE/MAX Lawn Sign and organically drove people to RE/MAX offices, agents to get a sign.

[Watch](#) the CityTV segment, highlighting RE/MAX lawn sign.



7 Treat Accessibly Halloween Villages: Canadian Tire



What's next

Based on precedent setting action in 2021 with partners, provincial and municipal governments, homeowners, communities and schools...

Our vision 2022-2025:

1. 400,000 homes Treat Accessibly by 2025 in Canada at no cost for the signs and tips.
2. Help any neighbourhood become a Treat Accessibly Halloween Village on their own.
3. Help inspire 78% of Canadians, that don't identify with disabilities, to become accessibility allies everyday through Treat Accessibly.
4. Ensure 22% of Canadians, with disabilities, know neighbours, their community, our partners and government are behind a Treat Accessibly Halloween and the greater impact it brings to our future.
5. Support our government at every level accelerate accessible inclusion by exciting their community to champion accessible thinking and inclusion on Halloween.



Our hopes for Hamilton

1. Explore passing a similar binding resolution, as Toronto and Vaughan, to champion Treat Accessibly in Spring 2022.
2. Being able to share Hamilton will join Brampton, Toronto, Ottawa, Vaughan and other regions already planing to support Treat Accessibly at the June 2022 meeting of the Ontario Accessibility Advisory Committees.
3. Hamilton communicates the Treat Accessibly movement to homeowners through corporate communications and distribute our Free Treat Accessibly Lawn Signs through their October events and municipally run properties.
4. Consider a City Hall ceremony to bring awareness and support to the movement of Accessible Halloween.

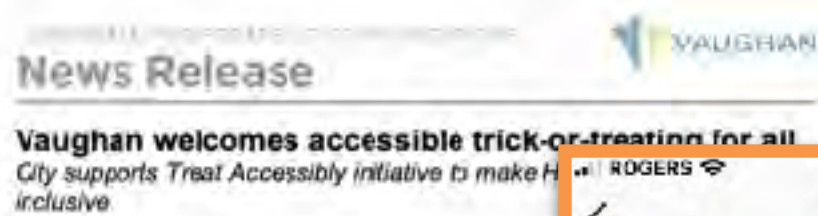

Download the sign online or pick up a free sign from the source Oct. 31.

TORONTO Item

MM37.20	ACTION
---------	--------

Accessible Trick-or-Treating - Tre
Frances Nunziata, seconded by C

City Council Decision
 City Council on November 9, 10 and 12, 20

1. City Council direct Strategic Commuic the Treat Accessibly initiative, through the e
2. City Council direct that Motion MM37.2 Committee, Ontario's Minister for Seniors a Parliament and Members of Parliament who



City of Brampton - 20
 Brampton is a Mosaic, an dedicated to increasing for all.

There's still time to put a @treataccessibly sign on to let trick-or-treaters kn experience a barrier-free your home! Learn more: beOE50GBvxX

accessibility



Download the sign or pick up a free sign from the source Oct. 31.

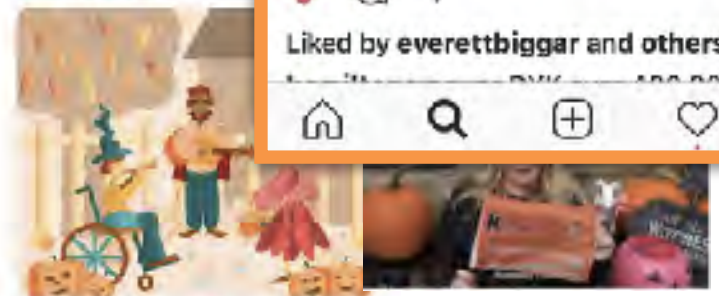

Happy Halloween EveryBODY!

from our founding family,
Siena, Rich and Natasha







Parent Thank You Video Media Selects

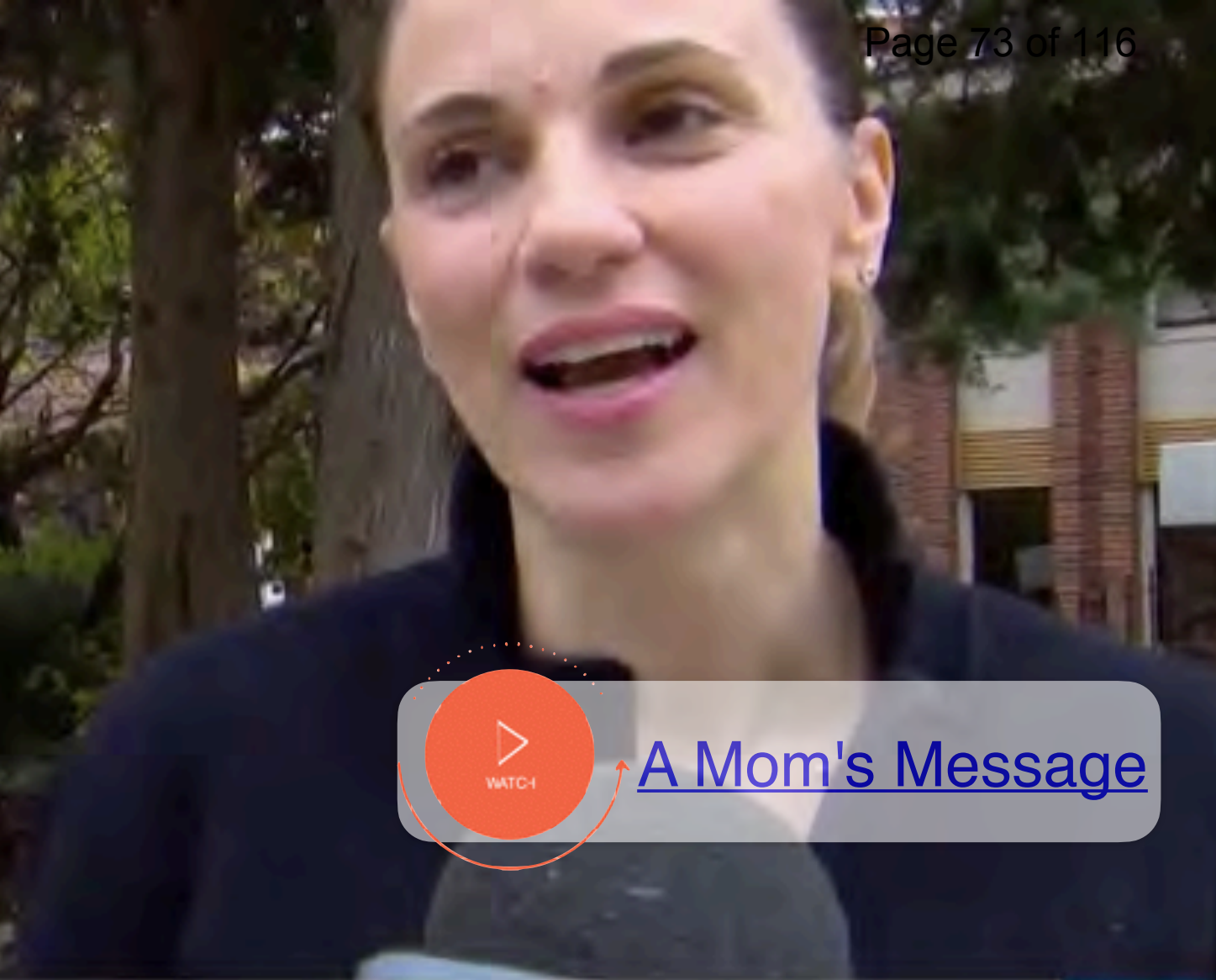

Gabriel's Mom , Fabiana.



 [A Mom's Message](#)

City News

FABIANA BACCHINI
MOTHER

THU 9°

ESTIGATING AFTER A VIDEO POSTED ON SOCIAL MEDIA CAPTURED A HALL MONITOR TELLING A STUDENT WHO IS TRANSGENDER THEY 6:25 PM



[CBC National with Heather Hiscox](#)



[CP24 Toronto 2021 TV Segment](#)

E-CARGO BIKE

PILOT PROGRAM



Ontario Cargo E-Bike Pilot Program

Advisory Committee for Persons with Disabilities

June 14th, 2022



What is a Cargo E-Bike?

- Cargo e-bikes are a type of electric-powered bike with a platform or box to carry larger items like packages and boxes for deliveries
- Can be used for personal use or for commercial deliveries
- The Highway Traffic Act's current definition of an e-bike excludes most cargo e-bikes:
 - E-Bike: max weight of 120 kg and motor output of up-to 500 W
 - Cargo E-Bike: greater than 55 kg and motor output of up-to 1,000 W



Image source: DHL



March 1, 2021: O. Reg. 141/21: Pilot Project – Cargo Powered-Assisted Bicycles approved

- Provincial pilot allows municipalities to opt-into permitting cargo e-bikes by passing a by-law.
- The pilot runs from March 1, 2021 to March 1, 2026.
- Ottawa & Toronto have opt-ed in. London is examining it.

Requirements Set-Out By the Province

- Helmet requirements
- Minimum age for operators
- Size and speed restrictions

Pilot Components the Municipality Can Dictate

- Where cargo e-bikes can be used (roads, bike paths, trails, etc.)
- Where cargo e-bikes can park/stop to load and unload
- How to monitor and report on the use of cargo e-bikes
- If insurance is required (the type and coverage)
- Other considerations relevant to the municipality



Provincial Pilot Requirements

Cargo E-Bike Requirements

- Have a **traditional bicycle design**
- Electric-powered motor with **max. output of 1000 W + pedals** to propel the bicycle
- Max. power-assisted speed of **32 km/h**
- Have a **platform, basket or container** for carrying cargo, parcels or goods
- Greater than **55 kilograms to an unlimited maximum weight**
- Have **two or three wheels**
- **Maximum** width of <1.3 m, length of 4 m, height 2.2 m, wheel width of 35 to 350 mm.

Operator Requirements

- At least **16 years of age**
- **Allow passengers only if the passenger is using a seat designed for passenger use**
- Driver and passengers **must wear a helmet**
- **Ensure that any load is loaded**, bound, secured, contained or covered.

Falls Under the Definition of a Cargo E-Bike



Tricycle cargo e-bike design with enclosed cargo box at the back



Reverse tricycle design with enclosed cargo box in the front



Passenger Trishaw

May Fall Under the Definition of a Cargo E-Bike



Depends on weight and power output



Image source: K. Gebhardt



Does Not Fall Under the Definition of a Cargo E-Bike





Other Factors to Consider

- Parking locations off-road
- Where they can operate (e.g. multi-use pathways, parks, higher speed roads)
- Speed, weight or power outputs
- Enforcement
- Permitting or insurance requirements



Benefits of Cargo E-Bikes



- Reduce vehicle congestion
- Mitigate demand for curbside space (parked delivery vehicles)
- More flexible delivery options for businesses
- Reduces air pollution, especially in high activity areas
- Supports the Climate Emergency Declaration
- Support the vision and objectives of the TMP and CMP





- **503** respondents
- **15%** of respondent already own or are planning to purchase an e-cargo bike in the next year
- **93% supportive** of a cargo e-bike pilot for personal use
- **94% supportive** of a cargo e-bike pilot for commercial use

Results from Public Engagement

Do you support allowing ecargo bikes on the following facilities?

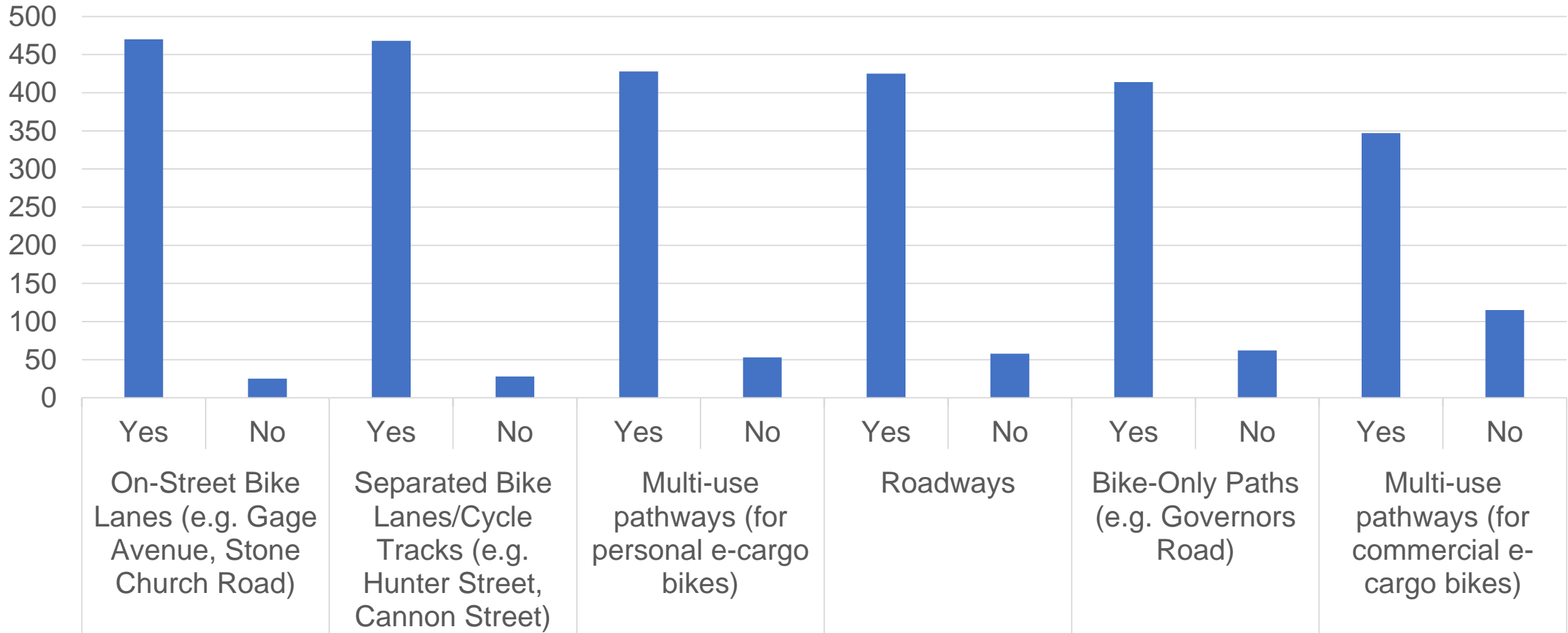

Do you support allowing e-cargo bikes to park on these facilities?

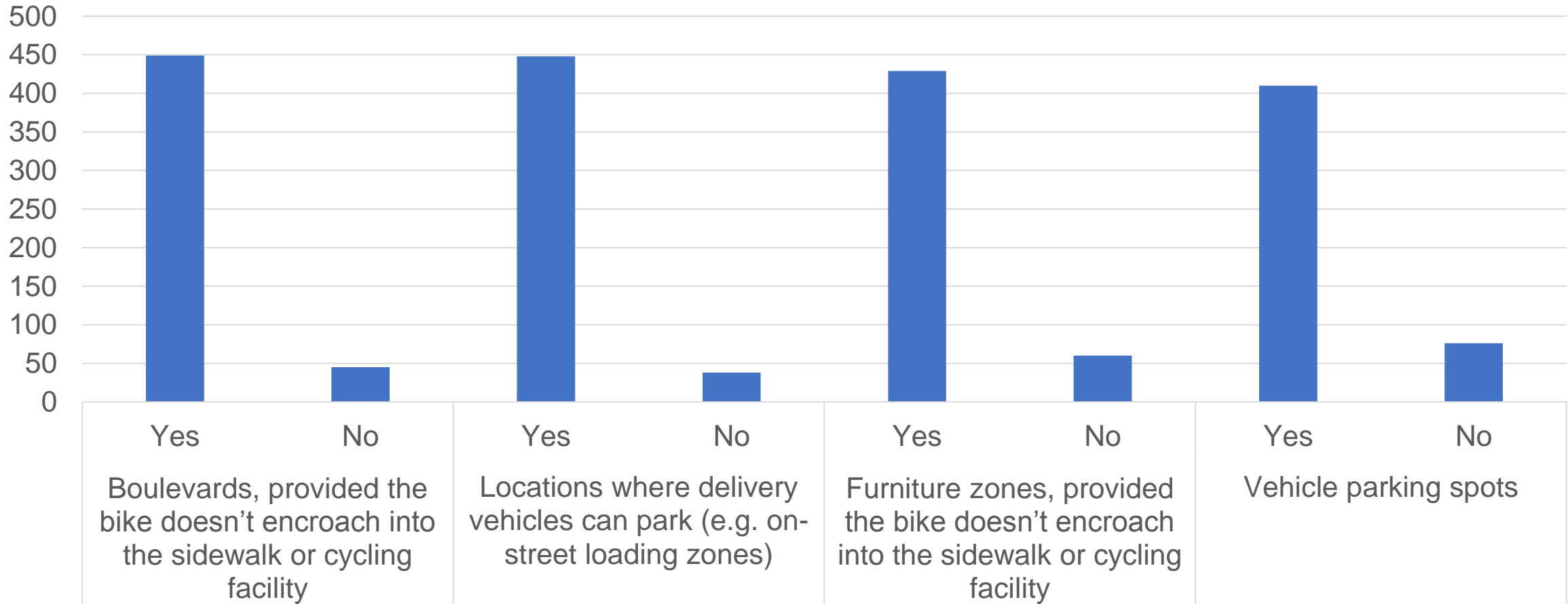



Proposed Pilot for Hamilton

- Similar to Toronto and Ottawa, Hamilton will create different by-laws for smaller, personal cargo e-bikes; and larger, commercial cargo e-bikes.
- Bikes that are heavier than 120kg and wider than 1.2m will be considered large or commercial ebikes and have different bylaws.

Less than 120kg and less than 1.2m wide

- Can travel and park in the same facilities as ebikes (roads, bike paths, not in parks unless otherwise signed).
- No insurance required.

Greater than 120kg or greater than 1.2m wide

- More work needs to be done to determine where large ecargo bikes can travel, and stop/unload.
- More work needs to be done to determine if insurance will be required.



- Share your comments via e-mail to sustainable.mobility@hamilton.ca
- Will review comments for consideration as we finalize a pilot program framework



Hamilton

THANK YOU



Hamilton

WHEELCHAIR ACCESSIBLE SWING PROPOSAL

May 2022

- Introductions
- Purpose of a Wheelchair Accessible Swing
- Previously Installed Wheelchair Accessible Swing in Hamilton
- Overview of our current project(s)
- Possible locations for the Wheelchair Accessible Swings
- Thoughts and Discussion
- Questions & Comments



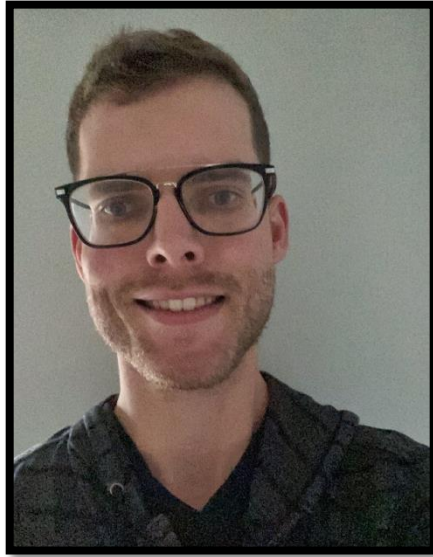

Kevin Kernaghan
Project Manager – Capital
Parks and Cemeteries



Andrea McDonald
Senior Project Manager – Capital
Parks and Cemeteries



Purpose of a Wheelchair Accessible Swing

- Opportunities for all – both children and their friends/caregivers
- Social Interaction – using teamwork to move the swing
- Exercise – working to move the swing results in muscle engagement, balance stabilization
- Inclusive Placement – the swing is ideally installed within the overall play area



Hamilton's Wheelchair Accessible Swing Pilot Project

- Hamilton started a pilot project by installing a wheelchair accessible swing at Gage Park

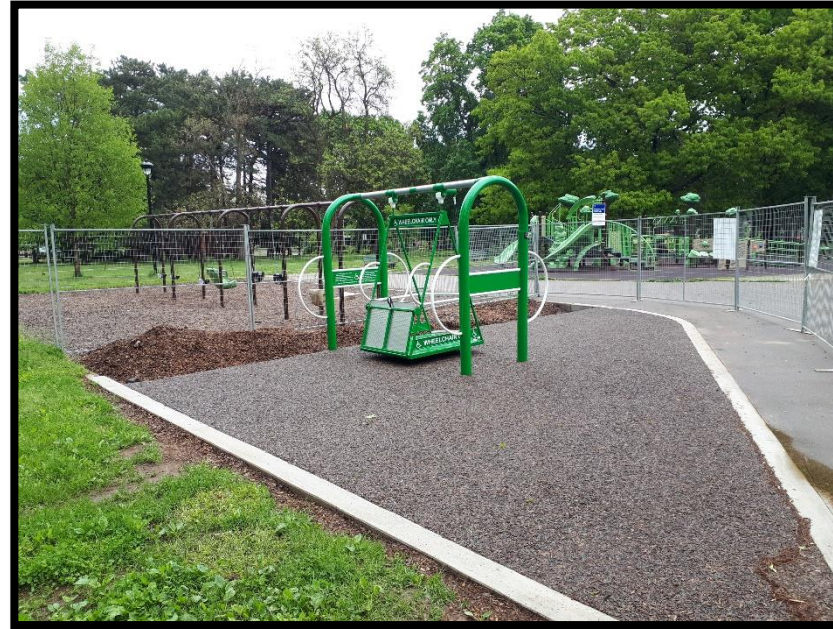

Project Overview

- Supply and install Wheelchair Accessible Swings at two park locations
- Heritage Green Sports Park (355 First Road West)
- William Connell Park (1086 West 5th Street)



We-Go Swing by ABC Recreation



We-Go Swing by ABC Recreation



We-Go Swing by ABC Recreation

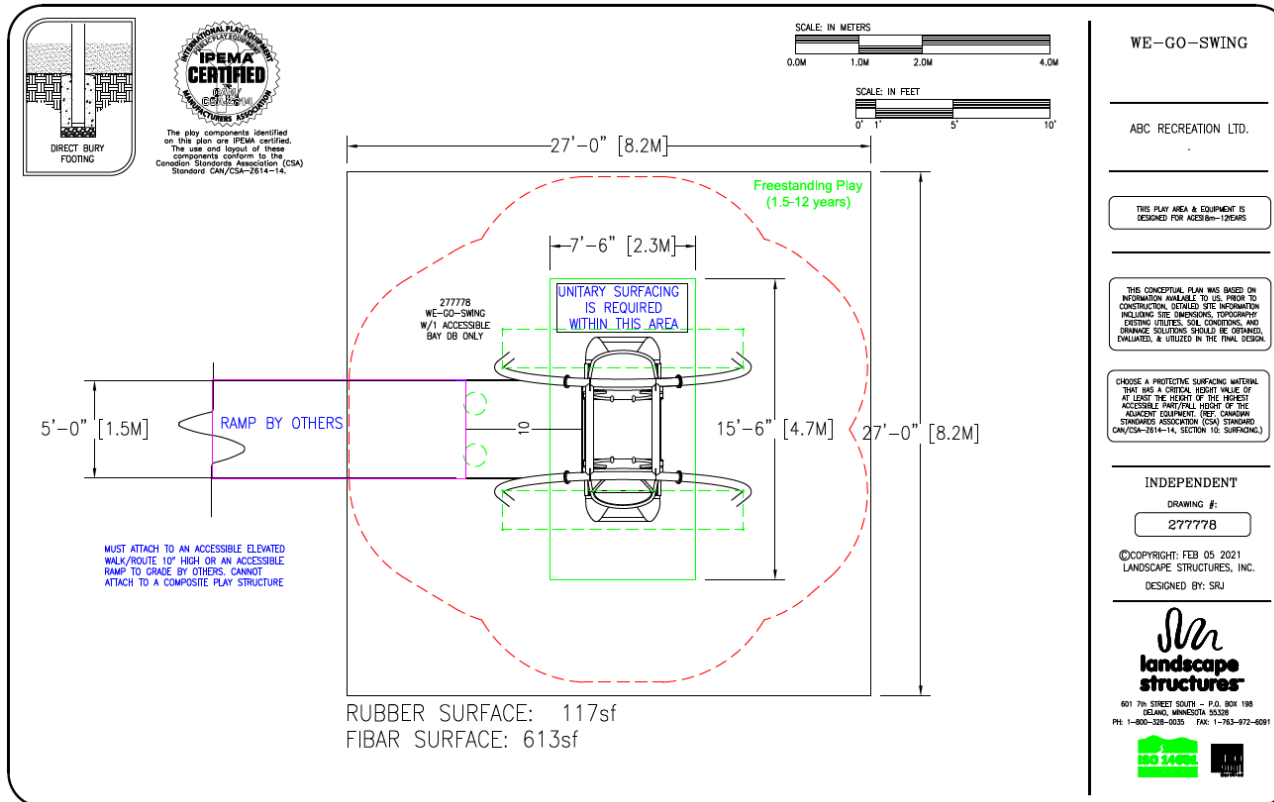

Heritage Green Sports Park – 355 First Road West

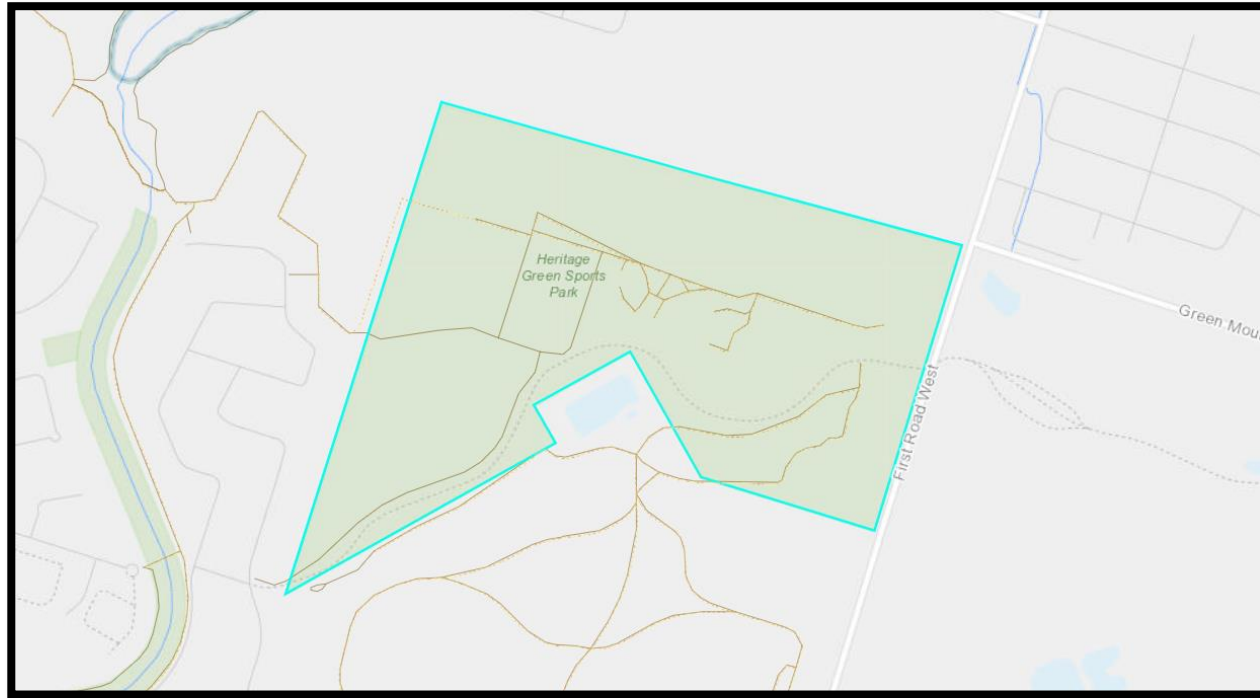

Heritage Green Sports Park – 355 First Road West

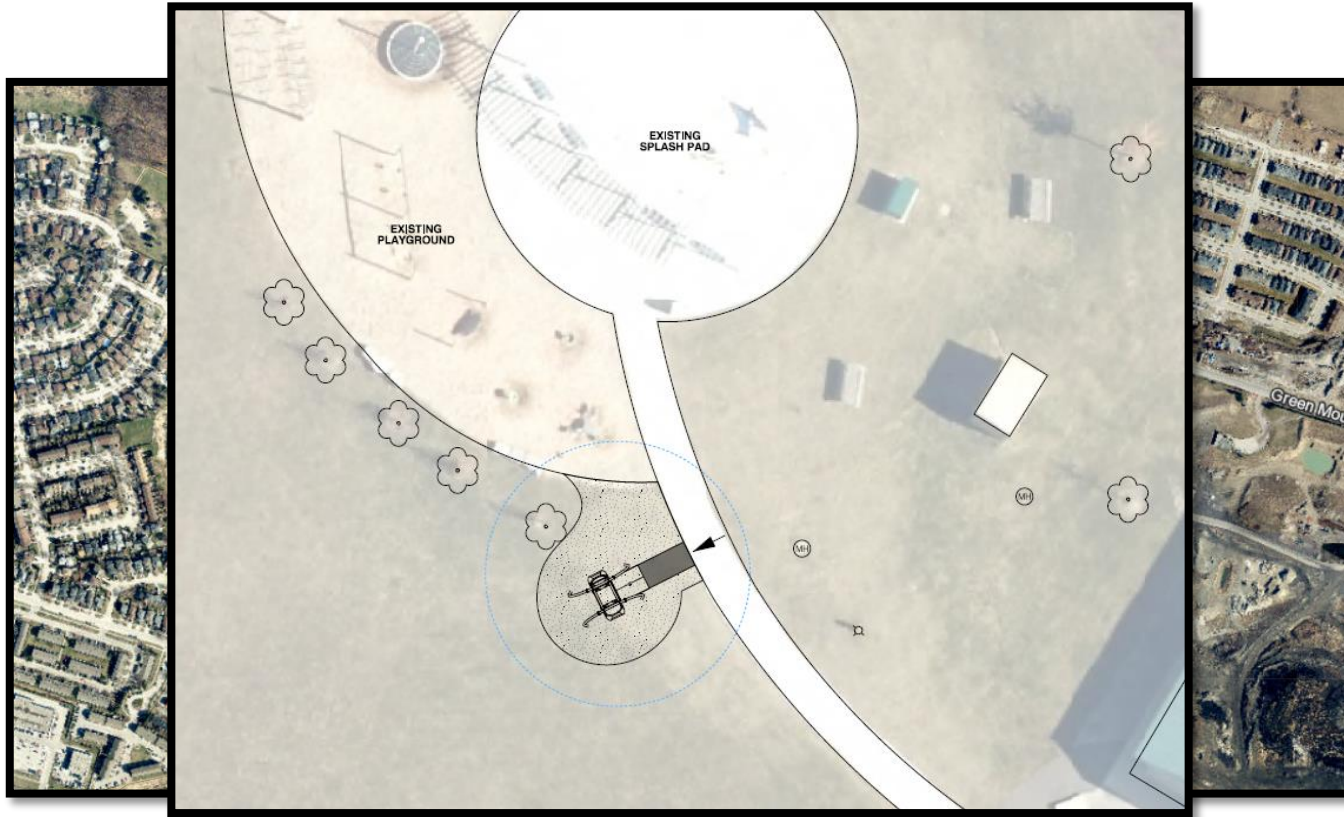

Heritage Green Sports Park – 355 First Road West



William Connell Park – 1086 West 5th Street

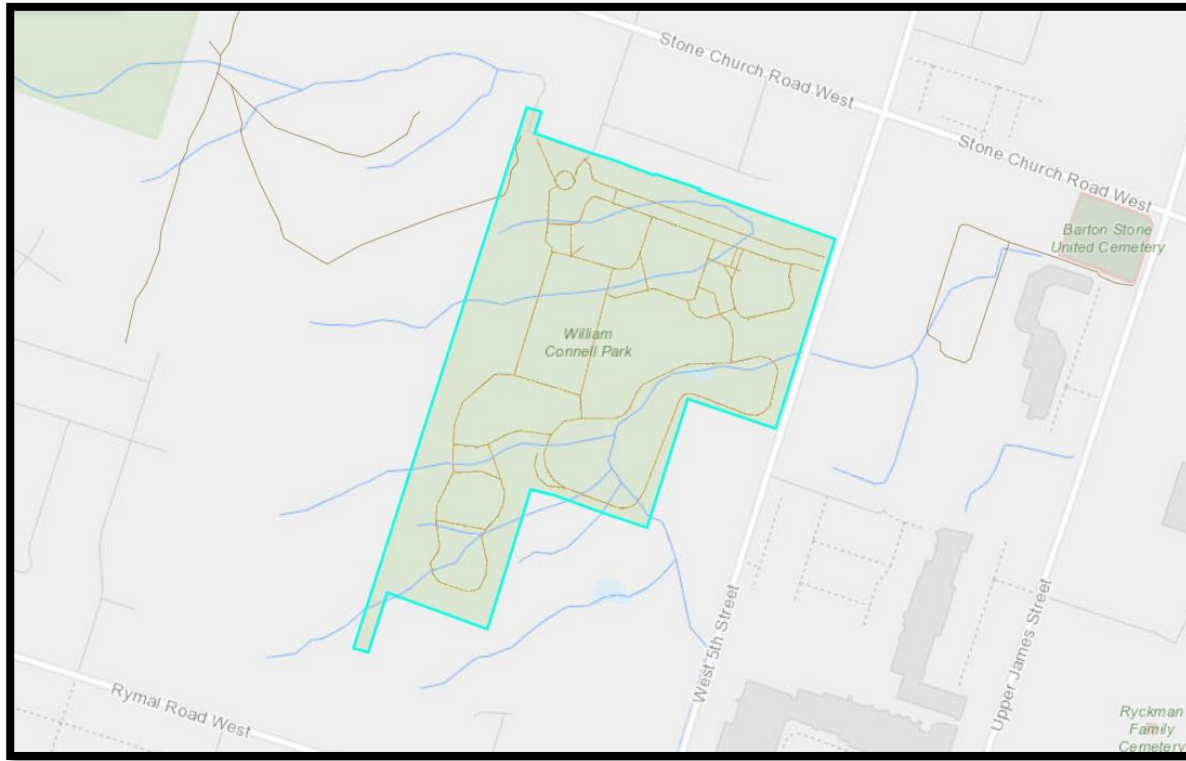

William Connell Park – Swing Location Option 1

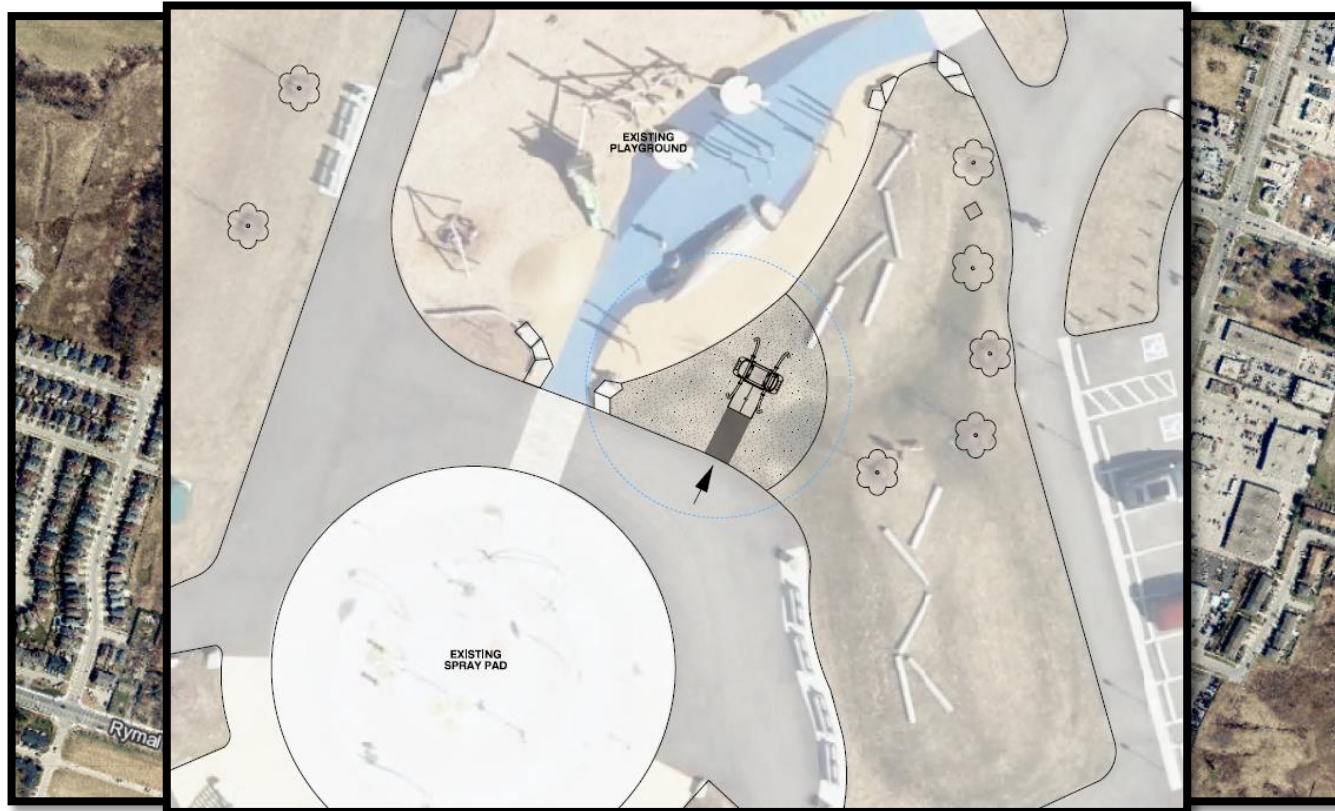

William Connell Park – Swing Location Option 1



William Connell Park – Swing Location Option 2



William Connell Park – Swing Location Option 2



Thoughts & Discussion



Questions / Comments?



CITY OF HAMILTON

NOTICE OF MOTION

**Advisory Committee for Persons with Disabilities:
June 14, 2022**

MOVED BY J. CARDNO.....

SECONDED BY.....

Operation of Vehicles in Public Parks and Green Spaces

WHEREAS, parks and green spaces have been recognized as valuable, contributing to the good health of City residents and as a result of the COVID-19 Pandemic, use of these spaces has increased;

WHEREAS, any vehicular traffic moving through a park not only reduces such benefits but presents a threat that is unexpected in a park, particularly for those with disabilities and using mobility devices;

WHEREAS, invisible disabilities are not easily identified and operators of vehicles may not be sensitive to related fear and anxiety that results when an unexpected vehicle suddenly comes near;

WHEREAS, the public in vehicles may mistake hard surface paths as roadways because of other vehicles or evidence of vehicle use and will enter and travel at speed presenting a very real danger to park users and especially those unable to move quickly out of the way due to mobility or disability limitations; and

WHEREAS, City staff should receive sensitivity and awareness training regarding those with disabilities as part of customer service when dealing with the public, particularly for new and seasonal staff.

THEREFORE, BE IT RESOLVED:

1. That staff be directed to review policies and procedures regarding vehicle traffic and presence of vehicles throughout parks and green spaces and recommend actions to keep the presence and operation of vehicles in parks and green spaces to a minimum, as follows;
 - (i) Ensure the use of public roads rather than park pathways unless it is an emergency; and
 - (ii) Ensure that pathways are not easily accessible to vehicles and that the use of barriers to limit vehicles does not restrict or inhibit the use of mobility devices.

12.1

2. That staff be directed to provide regular sensitivity and awareness training for staff as part of customer service when dealing with the public, including new and seasonal staff, to include awareness of the benefits parks and green spaces offer and ways to decrease any activity that interferes with those benefits.

13.3

Advisory Committee for Persons with Disabilities (ACPD)

Presenters List as of June 14, 2022

The following is a listing of invited presenters for future Advisory Committee for Persons with Disabilities meetings:

- (a) **Invitee:** Denise Davy, author of Her Name Was Margaret: Life and Death on the Streets
Issue:
Date Action Initiated: October 12, 2021, Advisory Committee for Persons with Disabilities Report 19-011, Item 4(a).
Status: Ongoing – Invitation sent to attend a future meeting.

- (b) **Invitee:** Crisis Outreach and Support Team (COAST)
Issue: To discuss the services that they provide to those with mental health issues and who are in crisis.
Date Action Initiated: February 8, 2022, Advisory Committee for Persons with Disabilities Report 22-002, Item 4.
Status: Tentatively scheduled for July.

- (c) **Invitee:** Sara Mayo, Geographical Information Systems Specialist, Social Planning & Research Council of Hamilton
Issue: To discuss findings of the relationship between poverty and disability across the City of Hamilton.

Date Action Initiated: February 8, 2022, Advisory Committee for Persons with Disabilities Report 22-002, Item 7.

Status: On-going. Invitation sent to attend a future meeting.

- (d) **Invitee:** Rich Padulo, Founder of Treat Accessibly
Issue: To discuss the Treat Accessibly campaign.
Date Action Initiated: February 8, 2022, Advisory Committee for Persons with Disabilities Report 22-002, Item 8.
Status: Scheduled for today's meeting.