



City of Hamilton
HAMILTON RENEWABLE POWER INCORPORATED
BOARD OF DIRECTORS
REVISED

Meeting #: 23-003
Date: December 12, 2023
Time: 11:30 a.m.
Location: Council Chambers
Hamilton City Hall
71 Main Street West

1. CALL TO ORDER
2. APPROVAL OF AGENDA
3. DECLARATIONS OF INTEREST
4. ADOPTION OF MINUTES
 - 4.1 June 26, 2023
5. OPERATIONS UPDATE
 - *5.1 Glanbrook Landfill Site – Proposed Extension to the Toromont Operations and Maintenance Services Agreement
 - *5.2 Renewable Energy Options Assessment of HRP Inc. - Woodward Operations
6. STAFF PRESENTATIONS
7. MOTIONS
 - *7.1 Resolutions of the Hamilton Renewable Power Inc. Board of Directors - REVISED
8. ADJOURNMENT

HAMILTON RENEWABLE POWER INC.
Board of Directors
Minutes 23-002
June 26, 2023
Council Chambers
Hamilton City Hall

Present: **Board of Directors:**
Mayor A. Horwath
Councillors C. Cassar (Chair), T. Hwang, M. Tadeson and
M. Wilson

Officers:
C. Khan, President
I. Maharjan, Senior Vice-President
L. Campbell, Vice-President, Operations
I. Herman, Accountant
J. Pilon, Acting Secretary

Also Present: David McKenna, Solicitor
S. Hesmer, Manager, Accounting Services
M. Gauthier, Legislative Coordinator
J. Versace, Legislative Assistant

**THE FOLLOWING ITEMS WERE REFERRED TO THE HAMILTON
RENEWABLE POWER INC. SHAREHOLDERS:**

**1. Hamilton Renewable Power Inc. (HRP Inc.) Operating and Financial
Update (Item 5.1)**

(Hwang/Tadeson)

(a) That the Information Report respecting Hamilton Renewable Power
Inc. (HRP Inc.) Operating and Financial Update, be received; and

Result: Motion CARRIED by a vote of 5 to 0, as follows:

Yes	-	Mayor Andrea Horwath
Yes	-	Ward 12 Councillor Craig Cassar
Yes	-	Ward 4 Councillor Tammy Hwang
Yes	-	Ward 11 Councillor Mark Tadeson
Yes	-	Ward 1 Councillor Maureen Wilson

(M. Wilson/Hwang)

(b) That staff be requested to report back by Q1 2024 with the strategy
that will guide Hamilton Renewable Power Incorporated Board of
Directors during the consideration of the future status of Hamilton
Renewable Power Inc.

Result: Motion CARRIED by a vote of 5 to 0, as follows:

Yes - Mayor Andrea Horwath
Yes - Ward 12 Councillor Craig Cassar
Yes - Ward 4 Councillor Tammy Hwang
Yes - Ward 11 Councillor Mark Tadeson
Yes - Ward 1 Councillor Maureen Wilson

2. Hamilton Renewable Power Inc. (HRP Inc.) Resolutions (Item 6.1)

Hamilton Renewable Power Inc. Board of Directors Resolutions;
Hamilton Renewable Power Inc. 2022 Audited Financial Statements; and
Hamilton Renewable Power Inc. 2023 Draft Budget

(Tadeson/Hwang)

(i) 2022 AUDITED FINANCIAL STATEMENTS

- (a) BE IT RESOLVED that the audited financial statements for the 2022 fiscal year (attached hereto as Schedule "A") be approved.

(ii) 2023 BUDGET

- (a) BE IT RESOLVED that the 2023 budget (attached hereto as Schedule "B") be approved and adopted.

(iii) APPOINTMENT OF OFFICERS

- (a) BE IT RESOLVED that Indra Maharjan, having consented to act as Senior Vice-President of the Corporation, is hereby appointed as Senior Vice-President of the Corporation commencing on June 26, 2023 and continuing thereafter until their successor is duly appointed.

(iv) CONFIRMATORY ACTIONS

- (a) BE IT RESOLVED that the officers of the Corporation are, and each acting alone is, hereby authorized to do and perform any and all such acts, including execution of any and all documents and certificates, as such officers shall deem necessary or advisable, to carry out the purposes and intent of the foregoing resolutions.
- (b) BE IT FURTHER RESOLVED that any actions taken by such officers prior to the date of the foregoing resolutions adopted hereby that are within the authority conferred thereby are hereby ratified, confirmed and approved as the acts and deeds of the Corporation.

- (c) THE FOREGOING RESOLUTIONS are hereby consented to by all of the directors of the Corporation pursuant to the *Business Corporations Act* (Ontario), R.S.O. 1990, c. B.16, as evidenced by such directors' signatures hereto.

Result: Motion CARRIED by a vote of 5 to 0, as follows:

Yes	-	Mayor Andrea Horwath
Yes	-	Ward 12 Councillor Craig Cassar
Yes	-	Ward 4 Councillor Tammy Hwang
Yes	-	Ward 11 Councillor Mark Tadeson
Yes	-	Ward 1 Councillor Maureen Wilson

FOR INFORMATION:

The meeting was called to order at 2:30 p.m.

(a) CHANGES TO THE AGENDA (Item 2)

The Secretary advised the Board of the following were changes to the agenda.

5. OPERATIONS UPDATE

- 5.1 Hamilton Renewable Power Inc. (HRP Inc.) Operating and Financial Update - REVISED

6. MOTIONS

- 6.1 Hamilton Renewable Power Inc. (HRP Inc.) Resolutions - REVISED

(Hwang/Tadeson)

That the Agenda of the June 26, 2023 meeting of the Hamilton Renewable Power Inc. (HRPI) Board of Directors be approved, as amended.

Result: Motion CARRIED by a vote of 4 to 0, as follows:

Absent	-	Mayor Andrea Horwath
Yes	-	Ward 12 Councillor Craig Cassar
Yes	-	Ward 4 Councillor Tammy Hwang
Yes	-	Ward 11 Councillor Mark Tadeson
Yes	-	Ward 1 Councillor Maureen Wilson

(b) DECLARATIONS OF INTEREST (Item 3)

There were no declarations of interest.

(c) **ADOPTION OF MINUTES (Item 4)**

(a) **February 24, 2023 (Item 4.1)**

Councillor M. Wilson noted that she was absent at the February 24, 2023 meeting of the Hamilton Renewable Power Inc. (HRPI) Board of Directors, and requested that the minutes be amended to reflect her absence.

(Hwang/Tadeson)

That the Minutes of the meeting of the Hamilton Renewable Power Inc. (HRPI) Board of Directors held on February 24, 2023 be approved, as amended.

Result: Motion CARRIED by a vote of 4 to 0, as follows:

Absent	-	Mayor Andrea Horwath
Yes	-	Ward 12 Councillor Craig Cassar
Yes	-	Ward 4 Councillor Tammy Hwang
Yes	-	Ward 11 Councillor Mark Tadeson
Yes	-	Ward 1 Councillor Maureen Wilson

(d) **OPERATIONS UPDATE (Item 5)**

(i) **Hamilton Renewable Power Inc. (HRP Inc.) Operating and Financial Update (Item 5.1)**

Isabela Herman, HRP Inc. Accountant, addressed the Board respecting the Hamilton Renewable Power Inc. (HRP Inc.) Operating and Financial Update, with aid of a PowerPoint presentation.

(Hwang/Tadeson)

That the presentation respecting the Hamilton Renewable Power Inc. (HRP Inc.) Operating and Financial Update, be received.

Result: Motion CARRIED by a vote of 5 to 0, as follows:

Yes	-	Mayor Andrea Horwath
Yes	-	Ward 12 Councillor Craig Cassar
Yes	-	Ward 4 Councillor Tammy Hwang
Yes	-	Ward 11 Councillor Mark Tadeson
Yes	-	Ward 1 Councillor Maureen Wilson

For disposition of this matter, please refer to Item 1.

(e) **ADJOURNMENT (Item 8)**

(Tadeson/Hwang)

There being no further business, the meeting adjourned at 3:38 p.m.

Result: Motion CARRIED by a vote of 5 to 0, as follows:

Yes	-	Mayor Andrea Horwath
Yes	-	Ward 12 Councillor Craig Cassar
Yes	-	Ward 4 Councillor Tammy Hwang
Yes	-	Ward 11 Councillor Mark Tadeson
Yes	-	Ward 1 Councillor Maureen Wilson

Respectfully submitted,

Chair, Councillor C. Cassar
Hamilton Renewable Power Inc.
Board of Directors

Janet Pilon, Acting City Clerk
Acting Secretary to Hamilton Renewable Power Inc.
June 26, 2023



INFORMATION UPDATE

TO:	Chair and Members of the HRP Inc. Board
DATE:	December 12, 2023
SUBJECT/REPORT NO:	Glanbrook Landfill Site – Proposed Extension to the Toromont Operations and Maintenance Services Agreement
WARD(S) AFFECTED:	N/A
PREPARED BY:	Linda Campbell Indra Maharjan
SUBMITTED BY:	Carlyle Khan, President, HRP Inc.
SIGNATURE:	

The purpose of this Information Update is to advise and inform the HRP Inc. Board of Directors re: the proposed extension to the Toromont Operations and Maintenance Services Agreement for the Glanbrook Landfill site.

Overview

- The energy generation project at the Glanbrook Landfill site came online in 2007.
- Hamilton Renewable Power Inc. (HRP Inc.) originally entered into an Operations and Maintenance Services Agreement with Toromont Industries Ltd. (Toromont) in 2007 in order to provide maintenance and operational support for the Glanbrook site. The current Operations and Maintenance Services Agreement with Toromont expires on December 18, 2023.
- Toromont has prepared an amending agreement to extend the term of the current Operations and Maintenance Services Agreement (with no price change other than the annual consumer price index increases for inflation). The amending agreement as presented by Toromont contemplates a 4-year extension, which would match HRP Inc.'s current Feed-In-Tariff (FIT) contract with the Independent Electricity System Operator (IESO) that ends in December 2027. Staff are also considering the viability of different structures for the extension term, including options for renewal terms, for example, a 2-year extension term with a subsequent 2-year renewal option and a further 1-year renewal option (any such renewal options being exercisable by the City's in order to provide the City with flexibility).

OUR Vision: To be the best place to raise a child and age successfully.

OUR Mission: To provide high quality cost conscious public services that contribute to a healthy, safe and prosperous community, in a sustainable manner.

OUR Culture: Collective Ownership, Steadfast Integrity, Courageous Change, Sensational Service, Engaged Empowered Employees.

Strategic Background

- HRP Inc. presently has two 1.6 megawatt biogas fuelled cogeneration units that provide renewable electricity to Ontario's electricity grid pursuant to the aforementioned FIT contract. The systems at this location have been operated and maintained since installation by Toromont with oversight and administration provided by City staff from the Waste Management and Energy Management divisions.
- Toromont were the original supplier of the cogeneration units at the Glanbrook site and as such are best suited to continue to operate and maintain such units.
- Since the current Operations and Maintenance Services Agreement with Toromont expires on December 18, 2023, staff are requesting HRP Inc. Board approval to extend the term of the Operations and Maintenance Services Agreement.

Key Facts

- The Glanbrook cogeneration units provide annual energy generation revenue of approximately \$1.24 million. The current Operations and Maintenance Services Agreement costs HRP Inc. approximately \$683,706 per annum, with such additional expenditures for non-scheduled maintenance as may be required from time to time.

OUR Vision: To be the best place to raise a child and age successfully.

OUR Mission: To provide high quality cost conscious public services that contribute to a healthy, safe and prosperous community, in a sustainable manner.

OUR Culture: Collective Ownership, Steadfast Integrity, Courageous Change, Sensational Service, Engaged Empowered Employees.



INFORMATION UPDATE

TO:	Chair and Members of the HRP Inc. Board of Directors
DATE:	December 12, 2023
SUBJECT/REPORT NO:	Renewable Energy Options Assessment of HRP Inc. - Woodward Operations
WARD(S) AFFECTED:	N/A
PREPARED BY:	Linda Campbell Indra Maharjan
SUBMITTED BY:	Carlyle Khan, President, HRP Inc.
SIGNATURE:	

The purpose of this Information Update is to advise and inform the HRP Inc. Board of Directors on the Renewable Energy Options Assessment of HRP Inc. - Woodward Operations.

Overview

- The existing twenty (20) year electricity supply agreement between Hamilton Renewable Power Inc. (HRP Inc.) and the Independent Electricity System Operator (IESO) for the Woodward cogeneration plant ends in December 2025.
- In preparation for the end of this existing contract, HRP Inc. engaged CH2M HILL Canada, a Jacobs Company (Jacobs), to review renewable energy options to assess what would be the best use of the biogas produced at the Woodward Water and Wastewater Treatment Plant (WWTP).
- Jacobs was engaged to determine if next steps should be refurbishing/replacing or if a different technology should be implemented in conjunction with or instead of the biogas purification unit (BPU) at the WWTP.
- Jacobs took a multi-criteria evaluation approach with consideration of economic and non-economic criteria and weightings.
- Staff prepared Report HRP202201 to detail the findings and provide a shortlist of alternatives.

Jacobs Report Findings

OUR Vision: To be the best place to raise a child and age successfully.

OUR Mission: To provide high quality cost conscious public services that contribute to a healthy, safe and prosperous community, in a sustainable manner.

OUR Culture: Collective Ownership, Steadfast Integrity, Courageous Change, Sensational Service, Engaged Empowered Employees.

SUBJECT: Renewable Energy Options Assessment of HRP Inc. - Woodward
Operations – Page 2 of 3

Using digester gas generated on-site to produce renewable natural gas (RNG) to subsequently sell to a third-party would provide the highest combined non-economic and economic score from HRP Inc.'s perspective.

From the City's perspective, using the RNG within the City instead of selling to a third-party would have less of an economic benefit but would reduce greenhouse gas emissions by almost threefold (see Table 9 of the Jacobs report).

The 100% combined heat and power alternative would help the City reduce its overall energy intensity by producing electricity to be used at the WWTP. This alternative would also reduce the City's reliance on purchasing natural gas for the heating of digestors.

Jacobs Report Recommendations

The Jacobs report examines which method provides the greatest overall value from the production of RNG. The Jacobs report recommends a new RNG production facility be designed, built and operated at the WWTP. The estimated capital outlay required to design and build a new production facility, according to the Jacobs report, is \$4.3M. Accounting for design, project management and contingencies suggests that a capital budget of \$5M should be assumed but this number could be higher since the Jacobs report was prepared in mid-2022 and the cost of goods/labour has increased since then. Staff will seek to identify funding options to mitigate the expected capital costs. The Jacobs report also suggests annual revenues of approximately \$2.7M if RNG were to be sold to a third-party. Operating and maintenance costs are expected to be approximately \$1.1M annually.

The intent will be to switch from the existing HRP Inc. contractual electricity production when the FIT contract ends. Ideally, the new production facility will be ready to switch over to RNG production immediately after the FIT contract ends.

Next Steps

That staff proceed to engage a consultant and advance the conceptual preliminary design and develop both a financial business case, including funding options, and an environmental benefit assessment for RNG production, at a cost not to exceed \$150,000 to be drawn from HRP Inc.'s, 'cash reserve'.

Upon receiving Board approval, staff will proceed with developing a business case and assess financing options for the project. The preliminary work will further refine expected costs and include financial viability, including funding options. Once this preliminary work is complete, staff will report back to the HRP Inc. Board of Directors in

SUBJECT: Renewable Energy Options Assessment of HRP Inc. - Woodward
Operations – Page 3 of 3

2024. Milestones and timing details will be made available to the Board as the project progresses.

OUR Vision: To be the best place to raise a child and age successfully.
OUR Mission: To provide high quality cost conscious public services that contribute to a healthy, safe and prosperous community, in a sustainable manner.
OUR Culture: Collective Ownership, Steadfast Integrity, Courageous Change, Sensational Service, Engaged Empowered Employees.

HAMILTON RENEWABLE POWER INC.
(the "Corporation")

RESOLUTIONS OF THE BOARD OF DIRECTORS OF THE CORPORATION

1. EXTENSION OF TOROMONT OPERATIONS AND MAINTENANCE SERVICES AGREEMENT

WHEREAS the decision to allow the Corporation to execute an amending agreement (the "Agreement") in order to extend the term of the Operations and Maintenance Services Agreement between the Corporation and Toromont Industries Ltd. requires approval by the Board of Directors by written resolution signed by the Directors entitled to vote on such resolution at a meeting of the Board of Directors;

BE IT RESOLVED that the Directors of the Corporation hereby authorize and direct the President of the Corporation to execute, on behalf of the Corporation, together with all necessary ancillary documents, the Agreement, with content satisfactory to the President and in a form satisfactory to the Corporation's solicitor.

2. RENEWABLE NATURAL GAS DEVELOPMENT STUDY

WHEREAS at an August 30, 2022 Board of Directors meeting the Directors of the Corporation received Report HRP202201 (attached hereto as Appendix "A");

AND WHEREAS as a result of the 'lame duck' session of the Hamilton City Council prior to the 2022 Municipal Elections, the recommendations associated with Report HRP202201 were not ratified;

AND WHEREAS staff deem it prudent to seek renewed authorization from the Board of Directors as a result of the appointment of new members to the Board of Directors following the 2022 Municipal Elections;

BE IT RESOLVED that the consultant report identified as "Renewable Energy Options Assessment", prepared by Jacobs Engineering Group Inc., dated June 2, 2022 (attached hereto as Appendix "B") be received;

BE IT FURTHER RESOLVED that the Directors of the Corporation hereby authorize and direct staff to proceed to advance the concept design and develop both a financial business case, including funding options, and an environmental benefit assessment for renewable natural gas production, at a cost not to exceed \$150,000 to be drawn from the Corporation's 'cash reserve'.

3. CONFIRMATORY ACTIONS

BE IT RESOLVED that the officers of the Corporation are, and each acting alone is, hereby authorized and directed to do and perform any and all such acts, including execution of any other agreements, documents, notices, articles and/or certificates, as such officers shall deem necessary or advisable, to carry out the purposes and intent of the foregoing resolutions.

BE IT FURTHER RESOLVED that any actions taken by such officers prior to the date of the foregoing resolutions adopted hereby that are within the authority conferred thereby are hereby ratified, confirmed and approved as the acts and deeds of the Corporation.

THE FOREGOING RESOLUTIONS are hereby consented to by all of the Directors of the Corporation pursuant to the *Business Corporations Act* (Ontario), R.S.O. 1990, c. B.16, as evidenced by such Directors' signatures hereto.

DATED the 12th day of December, 2023.

Andrea Horwath

Maureen Wilson

Tammy Hwang

Mark Tadeson

Craig Cassar



RECOMMENDATION REPORT

TO:	Chair and Members of Hamilton Renewable Power Inc. Board
COMMITTEE DATE:	August 30, 2022
SUBJECT/REPORT NO:	Hamilton Renewable Power Inc. (HRP Inc.) Renewable Natural Gas Development (HRP202201) (City Wide)
WARD(S) AFFECTED:	City Wide
PREPARED BY:	Tom Chessman (905) 546-2424 Ext. 2494
SUBMITTED BY:	Rom D'Angelo President, Hamilton Renewable Power Inc.
SIGNATURE:	

RECOMMENDATION

- (a) That the consultant report identified as “Renewable Energy Options Assessment”, prepared by Jacobs Engineering Group Inc., dated June 2, 2022, attached as Appendix “A” to Report HRP202201 be received;
- (b) That staff proceed to advance the concept design and develop both a financial business case, including funding options and an environmental benefit for renewable natural gas (RNG) production, at a cost not to exceed \$100,000 to be drawn from the HRP Inc, ‘cash reserve’.

EXECUTIVE SUMMARY

The existing twenty (20) year electricity supply agreement between Hamilton Renewable Power Inc (HRP Inc.) and the Independent Electricity System Operator (IESO) for the Woodward cogeneration plant ends in December of 2025. To prepare for the end of this existing contract, a study was completed to assess what would be the best option for the use of the continued production of biogas at the Woodward Water and Wastewater Treatment Plant (WWWTP). The study confirms greatest overall value with the production of renewable natural gas (RNG). It is recommended a new RNG production facility be designed, built and operated at the Woodward site. Estimated capital according to the attached report is \$4.3M. Adding for design, project management fee and contingencies suggest a capital budget of \$5M be assumed. Staff will pursue funding source options to mitigate the expected capital costs. The report

OUR Vision: To be the best place to raise a child and age successfully.

OUR Mission: To provide high quality cost conscious public services that contribute to a healthy, safe and prosperous community, in a sustainable manner.

OUR Culture: Collective Ownership, Steadfast Integrity, Courageous Change, Sensational Service, Engaged Empowered Employees.

SUBJECT: Hamilton Renewable Power Inc. (HRP Inc.) Renewable Natural Gas Development (HRP202201) (City Wide) - Page 2 of 6

also suggests annual revenues expected to be secured would be approximately \$2.7M annually when RNG is sold to a third party. Operating and maintenance costs are expected to be approximately \$1.1M annually.

The intent will be to switch away from the existing HRP Inc. contractual electricity production when the contract ends. Ideally the new production facility will be ready to switch over to RNG production immediately after the electricity contract ends.

Based on recommendation (b) of this report, staff will proceed with developing a business case and assess financing options for this project. This preliminary work is estimated to an upset limit of \$100,000, which will further refine expected costs and include financial viability, including funding options. Once this work is completed staff will report back to the board in Q2 2023. Further updates on timing and completion will only become available after the project process begins. Milestones and timing details will be made available to the Board as the project proceeds.

In the short term there will be value in the sale of RNG to a third party as this generates revenue for HRP Inc. and in turn produces dividends for the City. As the City progresses towards its goal of Net Zero by 2050 there may be a time when the City would prefer to acquire the RNG and use it to lower the Corporate emissions. Flexibility will be built into the initial RNG agreement to allow for transition to the other supply options that may see the City purchasing the RNG from HRP Inc. for the emission reduction benefit.

Alternatives for Consideration – See Page 4

The attached report outlines the options that were assessed, which included continued electricity production, possible alternative energy production and the production of RNG. The RNG option is viable for multiple reasons, including revenue and the potential to be used to lower the corporate emissions, which is directly linked to the City of Hamilton's Climate Change Emergency, the Corporate Energy and Sustainability Policy and the Community Energy and Emission Plan.

Other alternatives were to operate a combined heat and power unit (CHP) and various scenarios of running both CHP and the RNG production. In the end, the RNG only option provides the best overall solution.

FINANCIAL – STAFFING – LEGAL IMPLICATIONS

Financial: In order to proceed to the next step, staff are requesting to further assess this project by retaining a consulting firm which will be funded by HRP Inc's 'cash reserve', to refine the site, system design and develop a business case that will explore the financial viability and the environmental benefits, at a cost not to exceed \$100,000.

Future Ask: HRP Inc. will need to secure capital to design, build and operate this RNG production facility. The report outlines a capital cost of \$4.3M but additional funds should be expected to allow for design, project management and contingencies. For these reasons HRP Inc. should anticipate a budget of approximately \$5M to complete the entire project, with the possibility of having some cost offset from federal or provincial funding programs.

Staffing: As the project is located at WWWT, it is expected that staff from Water will be required to manage this project. While this may not require extra staff, the existing staff resources should be noted as being critical to the RNG system installed and integrated into the WWWT operations.

Legal: There will be a requirement for HRP Inc. to enter into supply and construction related tenders and agreements that will be presented to the HRP Inc. Board as this project develops.

HISTORICAL BACKGROUND

HRP Inc. was created in 2005 when the previous Electricity Act prevented a municipality from becoming an electricity generator. HRP Inc. was formed and the City became the sole shareholder of HRP Inc. Since inception, HRP Inc. pays annual dividends to the City through its dividend policy and provides partial City staffing cost relief for both rate and levy budgets. There are two generation sites that both produce electricity from methane sources. The WWWT was first built in 2005 but in 2007 two further engines were installed at the Glanbrook Landfill site. The landfill also produces power under a twenty (20) year contracts, similar to the WWWT.

As these contracts come to an end, there needs to be an assessment to understand how best to use the available methane from the City's WWWT and the landfill. This report targets the WWWT as the contract ends in 2025, while the landfill contract ends in 2027.

Having completed the assessment on the best use of biogas at the WWWT, HRP Inc. is now poised to move ahead with plans to produce renewable energy. RNG has been growing in terms of acceptance, value and use along with counterparties with whom to establish supply agreements. RNG will also become a key part of the City's transit Pathway to Net Zero, as there are additional compressed natural gas (CNG) buses being purchased in the next three (3) years. These buses are typically used for twelve (12) years before retiring them as an asset. This suggests the City will be using CNG for at least fifteen (15) years and the need for RNG will play an important role as a fuel source option to mitigate emissions. There are other emission reduction portfolios such as the City's Corporate Buildings that will also have a need for RNG in the future. The

Corporate Fleet, Corporate Buildings and other operations in Public Works generates over 90% of the corporate emissions as of 2020. These portfolios all will benefit from some amount of RNG if they cannot switch to electricity. Even if sites and operations do switch to electricity, the electrical grid, while having low emissions, does generate some emissions which also need to be mitigated. RNG can provide one option for these conditions as we go forward.

POLICY IMPLICATIONS AND LEGISLATED REQUIREMENTS

The work that HRP Inc. is proposing favourably impacts the City's adoption of the Climate Change Emergency, the targets and Key Performance Indicator's (KPI's) found in the Corporate Energy and Sustainability Policy (Net Zero by 2050, expanded renewable energy), the Community Energy and Emission Plan and the City's Corporate Climate Change goals.

RELEVANT CONSULTATION

An industry leading consultant familiar with the WWWTTP was used to assess the renewable energy options in the attached report.

HRP Inc. staff worked closely with Water and wastewater staff to develop the study scoping and the review of the final study itself.

HRP Inc. will need to coordinate financial options to pursue this project. Financial development will also include identifying potential incentives from provincial or federal sources.

ANALYSIS AND RATIONALE FOR RECOMMENDATION

A sensitivity analysis was performed for both non-economic and economic parameters. See Table 1: Sensitivity Analysis below. For the non-economic sensitivity analysis, weightings were changed to better understand their impact on total scores. For the economic sensitivity analysis, RNG and electricity contract prices changed to better understand their impact on total scores.

The RNG third party contract price strongly factors into total scores. Similarly, the cost of electricity purchase/electricity contract prices strongly factors into total scores. The combined heat and power (CHP or Cogen) total score increase in proportion to the electricity unit prices. When the non-economic scores receive more weighting than the economic scores, total scores are expressed in a tighter band (64 to 92 as opposed to the baseline of 63 to 100).

ALTERNATIVES FOR CONSIDERATION

SUBJECT: Hamilton Renewable Power Inc. (HRP Inc.) Renewable Natural Gas Development (HRP202201) (City Wide) - Page 5 of 6

The attached report review options that were considered, including continued electricity production, possible alternative energy production and RNG. See Table: Sensitivity Analysis below for details. The RNG option provides the best alternative and was compared to multiple scenarios that included the Cogen running in conjunction with the RNG production equipment, including a sensitivity analysis. Other scoring was used to assess non-economic and economic conditions, and how the system ties into the Woodward digester and sludge heating demand. See Table 1: Sensitivity Analysis below for details.

Table 1: Sensitivity Analysis

Scenario	Total Score								
	100% RNG A	75% RNG A/ 25% CHP	50% RNG A/ 50% CHP	25% RNG A/ 75% CHP	100% RNG B	75% RNG B/ 25% CHP	50% RNG B/ 50% CHP	25% RNG B/ 75% CHP	100% CHP
Baseline	100	91	82	74	63	63	64	64	65
All criteria equal weighting	89	78	75	72	74	67	67	68	74
All category equal weighting	83	75	72	71	71	66	66	68	73
High energy intensity weighting	85	75	73	71	69	63	65	67	75
High technical weighting	92	76	73	69	75	64	64	65	74
High social weighting	86	76	73	71	72	66	66	68	73
RNG third party contract price - \$20/GJ	85	71	64	58	73	62	58	55	57
RNG third party contract price - \$30/GJ	85	68	59	51	54	45	43	43	47
Electricity purchase/contract price - \$0.10/kWh	85	71	64	59	60	52	52	53	58
Electricity purchase/contract price - \$0.14/kWh	85	75	73	72	60	56	60	66	75
Low total score economic weighting – 30%	79	67	65	65	76	65	64	65	72
Low total score economic weighting – 40%	82	70	66	65	74	64	62	63	68
'A' indicates that RNG is sold to a third party and 'B' indicates that RNG is sold to the City, keeping the RNG grid injection GHG emissions credit									

ALIGNMENT TO THE 2016 – 2025 STRATEGIC PLAN

OUR Vision: To be the best place to raise a child and age successfully.
 OUR Mission: To provide high quality cost conscious public services that contribute to a healthy, safe and prosperous community, in a sustainable manner.
 OUR Culture: Collective Ownership, Steadfast Integrity, Courageous Change, Sensational Service, Engaged Empowered Employees.

Clean and Green

Hamilton is environmentally sustainable with a healthy balance of natural and urban spaces.

APPENDICES AND SCHEDULES ATTACHED

APPENDIX "A" to Report HRP202201 - Renewable Energy Options Assessment



Review of Renewable Energy Options at the Woodward WWTP

Renewable Energy Options Assessment

June 2, 2022

Hamilton Renewable Power Inc.

Document History and Status

Revision	Date	Description	Author	Checked	Reviewed	Approved
R0	27-Sept-2021	Draft	T. Davis	T. Davis	D. Ross	D. Ross
R1	25-Oct-2021	Revision	T. Davis	T. Davis	D. Ross P. Burrowes	D. Ross
R2	2-Jun-2022	Final	T. Davis	T. Davis	D. Ross	D. Ross

Review of Renewable Energy Options at the Woodward WWTP

Project No: CE820000
Document Title: Renewable Energy Options Assessment
Revision: 2
Date: June 2, 2022
Client Name: HRPI
Client No: Client Reference
Project Manager: Taryn Davis
Author: Taryn Davis

CH2M HILL Canada Limited

245 Consumers Road
Suite 400
Toronto, ON M2J 1R3
Canada
T +1.416.499.9000

www.jacobs.com

© Copyright 2021 CH2M HILL Canada Limited. The concepts and information contained in this document are the property of Jacobs. Use or copying of this document in whole or in part without the written permission of Jacobs constitutes an infringement of copyright.

Limitation: This document has been prepared on behalf of, and for the exclusive use of Jacobs' client, and is subject to, and issued in accordance with, the provisions of the contract between Jacobs and the client. Jacobs accepts no liability or responsibility whatsoever for, or in respect of, any use of, or reliance upon, this document by any third party.

Contents

1. Introduction 1

1.1 Report Layout..... 1

2. Background Review..... 3

2.1 Process Overview 3

2.2 Corporate Climate Change Action 3

2.3 Historical Plant Data..... 4

2.3.1 Digester Gas Use 4

2.3.2 Thermal Energy Consumption..... 2

2.3.3 Natural Gas Consumption 2

2.4 Historical Operation and Maintenance Costs 2

2.5 Contract/Agreement Structures 2

3. Shortlisted Alternatives 4

4. Multi-criteria Evaluation Approach..... 5

4.1 Non-Economic 5

4.2 Economic..... 8

4.2.1 Capital Cost Basis..... 8

4.2.2 O&M Cost and Revenue Basis 8

4.2.3 Life-cycle Cost Basis 9

5. Digester Heating Requirements..... 10

5.1 Sludge Heating Demand..... 10

5.2 Cogeneration Thermal Energy Recovery..... 10

6. Energy Intensity 12

7. GHG Emissions 13

7.1 GHG Emissions Estimate 13

8. Carbon Intensity..... 15

8.1 Carbon Intensity Estimates 15

9. Renewable Energy Options Assessment and Recommendation 17

9.1 Non-Economic Evaluation..... 17

9.2 Economic Evaluation 18

9.3 Comparison..... 20

9.4 Sensitivity Analysis..... 22

9.5 Summary and Recommendations..... 24

9.5.1 100% RNG..... 24

9.5.2 100% CHP 24

9.5.3 Recommendations 24

10. References..... 25

Appendix A. GHG Emission Estimates

Appendix B. Non-Economic Evaluation Matrix

Appendix C. Sensitivity Analysis

1. Introduction

The City of Hamilton (City) declared a Climate Change Emergency and to achieve its goals, developed a Corporate Energy and Sustainability Policy, including a net zero target by 2050. Currently, energy is recovered from anaerobic digester gas generated from the treatment of residual solids at the Woodward Avenue Wastewater Treatment Plant (WWTP). A portion of the gas is purified by the City and sold as renewable natural gas (RNG), and a portion is used as fuel to a Cogeneration Facility, owned by Hamilton Renewable Power Inc. (HRPI), which generates electricity that is sold and heat that is used at the Woodward Avenue WWTP. Excess gas can also be flared.

The existing 1.6 MW Cogeneration Facility was commissioned in 2006. Electricity is generated behind-the-meter at 4,160 V and stepped up to 13.8 kV to provide electricity feed to the Woodward Avenue WWTP. Thermal energy is used to heat the Woodward Avenue WWTP digestion process. The facility is operated and maintained by Toromont Power Systems (Toromont) and Hamilton Community Energy (HCE) under contract with HRPI, with the contract term ending in 2025.

The existing Cogeneration Facility includes a gas compressor system (located in the Compressor Building), pressurized gas storage sphere, chiller and combined heat and power (CHP) unit. The CHP unit is approaching the end of its expected service life and HRPI would like to understand the net value of refurbishing/replacing the facility relative to other potential alternatives, considered in conjunction with or instead of the biogas purification unit (BPU) at the WWTP, which was commissioned in 2012. The decision will be based on optimizing the energy recovery from digester gas while balancing economic and non-economic benefits, where non-economic factors include technical, environmental and social considerations.

HRPI retained Jacobs (operating as legal entity CH2M HILL Canada Limited) to review renewable energy options for the digester gas generated at the Woodward Avenue Wastewater Treatment Plant (WWTP).

This report presents a review and analysis of renewable energy alternatives for the digester gas produced at the Woodward Avenue WWTP and presents a roadmap for developing an operating system that represents the best value to HRPI and the City, considering the City's greenhouse gas (GHG) and energy targets and goals.

1.1 Report Layout

The report is organized into the following Sections:

1. Background Review
2. Shortlisted Alternatives
3. Multi-criteria Evaluation Approach
4. Digester Heating Requirements
5. Energy Intensity
6. GHG Emissions
7. Carbon Intensity
8. Renewable Energy Options Assessment and Recommendation

The **Background Review** section provides an overview of the existing digesters and digester gas equipment at the Woodward Avenue WWTP and how they are interconnected. It also provides a high-level summary of the Corporate Energy and Sustainability Policy, a significant driver for this assessment. Historical plant data reviewed

are summarized in this section as well as existing contract/agreement structures, which influence non-economic and economic evaluation criteria.

Alternatives carried forward in the assessment are listed in the **Shortlisted Alternatives** section and their evaluation criteria detailed in the **Multi-criteria Evaluation Approach** section. In this section, non-economic (technical, environmental, and social) criteria as well as economic criteria are outlined, and weighting rationale provided.

The **Digester Heating Requirements, Energy Intensity, GHG Emissions, and Carbon Intensity** sections provide respective breakdowns of calculations completed to support both non-economic and economic values used in the assessment for each of the shortlisted alternatives. Digester heating requirements dictate how much natural gas is required to heat the digesters, a significant cost for the City, but also a significant source of GHG emissions. Energy Intensity and GHG emissions are two key performance indicators that the City uses to evaluate Corporate Energy and Sustainability Policy efforts, and as such are calculated for each of the shortlisted alternatives, where applicable. Carbon intensity impacts RNG market pricing. The development of calculations is presented in the corresponding section, to provide an understanding of how RNG contract prices may fluctuate.

The **Renewable Energy Options Assessment and Recommendation** section presents detailed scoring for non-economic and economic criteria as well as a comparison between the benefits and revenue of each shortlisted alternative. A sensitivity analysis, in which assessment weightings and economic unit prices are varied, is also presented in this section to show which items impact the evaluation scores the most, and to explicitly note which factors HRPI should consider in their ultimate selection process. Recommendations are made in this section based on these factors.

2. Background Review

2.1 Process Overview

At the Woodward Avenue WWTP, thickened raw sludge (TRS) and thickened waste activated sludge (TWAS) are stabilized in three (3) primary anaerobic digesters, producing digester gas as a byproduct. The plant currently uses the digester gas in either the on-site BPU or as fuel to the HRPI CHP unit, and any excess gas is flared (Figure 1).

The Greenlane™ BPU uses scrubbers to reduce constituents such as carbon dioxide (CO₂), hydrogen sulphide (H₂S), and siloxanes, refining the digester gas into 98 percent methane, also known as RNG. The RNG is sold by the City to a third party and distributed via the local natural gas distribution grid. Upstream of the Toromont Cat CHP unit, digester gas (sold to HRPI from the City) is passed through a chiller-condenser, de-mister and fine particulate filter. The digester gas is then combusted in the 1.6-megawatt (MW) combined heat and power (CHP) engine, producing electrical and thermal energy. The electricity produced is used behind-the-meter at the Woodward Avenue WWTP and the thermal energy produced is sold by HRPI to the City to heat digesters and offset the use of natural gas fueled boiler heat. The City's boilers can only operate on natural gas.

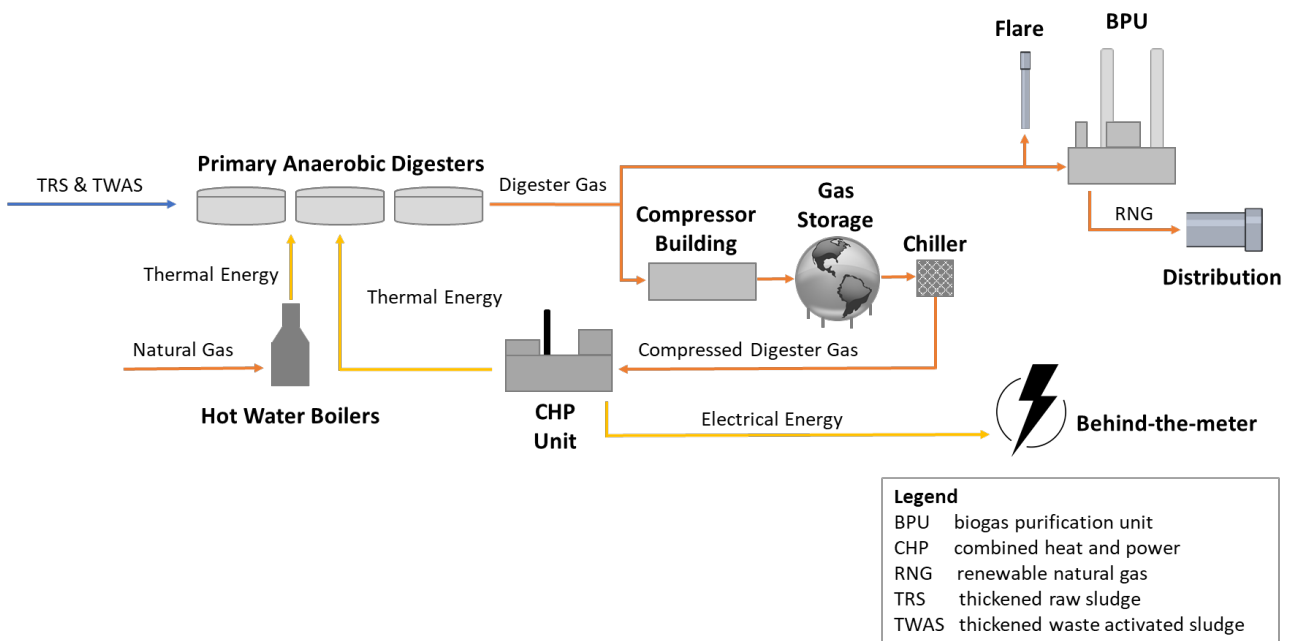

Figure 1. Woodward Avenue WWTP Digester Gas Production and Use

2.2 Corporate Climate Change Action

In 2019, Hamilton City Council declared a Climate Change Emergency (City of Hamilton, 2021). Subsequently, a Corporate Climate Change Task Force (CCCTF) was formed, with the mission to achieve net zero greenhouse gas emissions by 2050. The CCCTF collects, coordinates and advocates for corporate-wide climate change actions under the following nine (9) overarching goals:

1. Buildings
2. Active and Sustainable Travel
3. Transportation

4. Planning
5. Procurement
6. Protect and Restore the Natural Environment
7. Climate Adaptation
8. Diversity, Health, and Inclusion
9. Education and Awareness

This assessment falls under the Planning Goal, to encourage climate mitigation and adaptation practices at a planning level.

Table 1 outlines the 2020 Corporate Energy and Sustainability Policy energy intensity and GHG emission reduction targets (City of Hamilton, 2020).

Table 1. Corporate Energy Intensity and GHG Emission Reduction Targets

Year	Energy Intensity Reduction Targets	GHG Emissions Reduction and Offset Target
2030	45%	50%
2050	60%	100%
Basis <ul style="list-style-type: none"> ▪ “Energy Intensity” refers to the energy usage or consumption of a facility or facility operations using a common measure over a specific timeframe. For wastewater treatment plants, this is kWh/ML/d. ▪ “GHG Emissions” refers to the release of gases such as carbon dioxide (CO₂), methane (CH₄), and nitrous oxides (N₂O) which trap heat in the atmosphere. For wastewater treatment plants the total emissions are measured in tonnes CO₂e/ML/d. ▪ For the purposes of this evaluation, the facility’s rated capacity of 409 ML/d will be used 		

2.3 Historical Plant Data

2.3.1 Digester Gas Use

On average, the Woodward Avenue WWTP produces approximately 611,000 m³ of digester gas per month, with 50 percent used by the CHP unit, 33 percent used by the BPU, and the remainder flared (Figure 2).

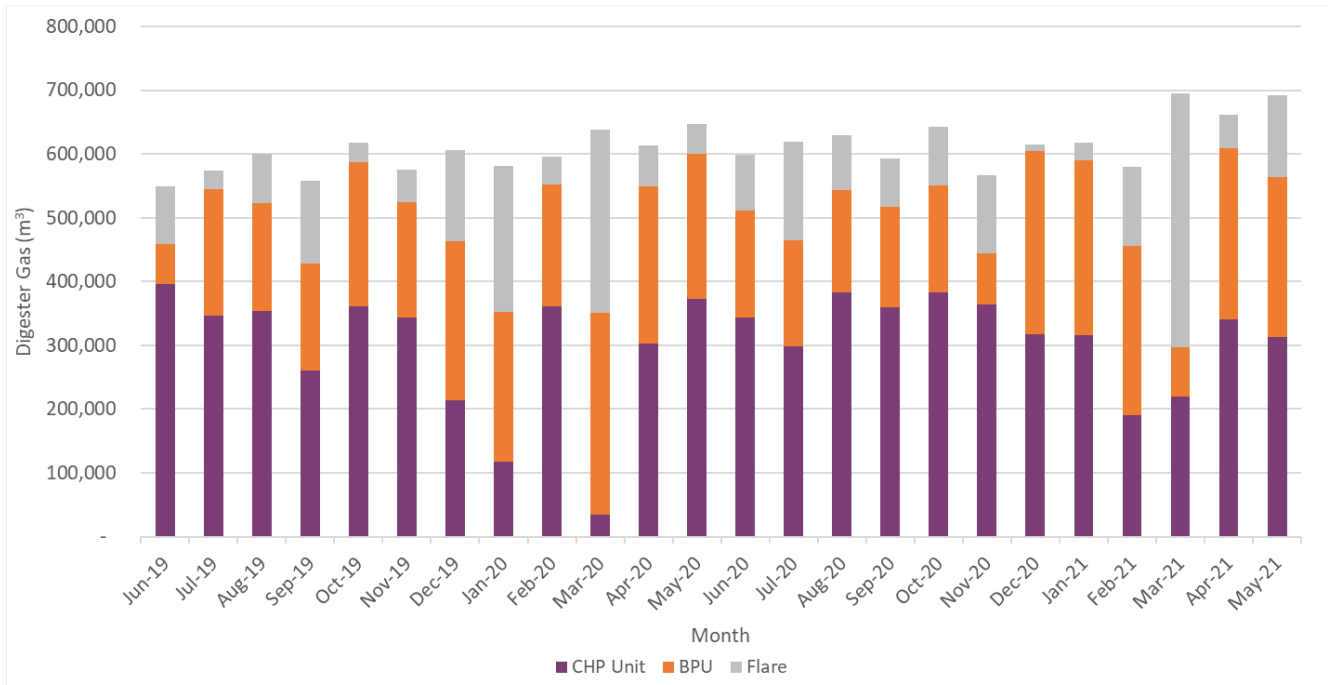

Figure 2. Historical Distribution of Digester Gas Use

2.3.2 Thermal Energy Consumption

The Woodward Avenue WWTP uses thermal energy produced by the CHP unit to heat its digesters. Based on invoice data provided for 2018 through 2020, the plant uses approximately 23,000 gigajoules (GJ), or 22,000 million British Thermal Units (mmBTU), annually from the CHP unit to heat digesters.

2.3.3 Natural Gas Consumption

The Woodward Avenue WWTP uses natural gas to supplement heating its digesters. The amount of natural gas used in the boilers to heat digester sludge was estimated since utility data available records plant-wide totals only. Based on the historical distribution of digester gas use, it is estimated that approximately 37,000 m³ of natural gas is purchased annually by the City for digester sludge heating.

2.4 Historical Operation and Maintenance Costs

HRPI provided the following operation and maintenance (O&M) costs for the BPU and CHP unit:

- BPU: \$400,000 per year (55,000 GJ at \$7/GJ) – includes electricity, service costs and RNG contract costs
- CHP unit: \$480,000 per year – Toromont and administrative costs

2.5 Contract/Agreement Structures

Table 2 outlines the current digester gas, electricity, thermal energy and RNG contracts/agreements relevant to this assessment. The financial details of these contracts were not available for this report.

Table 2. Current Contract Structures

Commodity	Parties	Contract/Agreement Description
Digester Gas	City, HRPI	<ul style="list-style-type: none"> ▪ The agreement between the City and HRPI defines the terms for the City to provide HRPI with digester gas to fuel the Cogeneration Facility ▪ The 1.6 MW Cogeneration Facility can consume upwards of 15,000 m³ of digester gas per day
Electricity	HRPI, Independent Electricity System Operator (IESO)	<ul style="list-style-type: none"> ▪ The Cogeneration Facility is connected to the Woodward Avenue WWTP through a behind-the-meter installation (metered at the CHP unit) ▪ HRPI currently holds a 20-year power purchase agreement contract with the IESO, to sell electrical energy produced by the Cogeneration Facility to the IESO ▪ This contract is coming to an end and roll-over of the existing contract is not likely
Thermal Energy	HRPI, City	<ul style="list-style-type: none"> ▪ Thermal energy produced by the Cogeneration Facility is sold by HRPI to the City to heat the Woodward Avenue WWTP digesters ▪ On average, HRPI sells 23,200 GJ (22,000 mmBTU) of thermal energy to the City annually
RNG	City, Third Party, Enbridge	<ul style="list-style-type: none"> ▪ The City sells RNG generated in the BPU to a third party, who also receives the associated carbon credits ▪ The City has an agreement (M13) with Enbridge to manage the distribution of the RNG to the third party

3. Shortlisted Alternatives

The shortlisted alternatives for energy recovery from digester gas generated at the Woodward Avenue WWTP and available to HRPI were documented at the project's kick-off meeting and further refined to capture a full range of potential scenarios, as follows:

1. 100% RNG
2. 75% RNG and 25% CHP
3. 50% RNG and 50% CHP
4. 25% RNG and 75% CHP
5. 100% CHP

These shortlisted alternatives are based on 15,000 m³/d of digester gas being available to HRPI. The first four (4) alternatives can further be broken down into sub-alternatives:

- A. Sell RNG to a third party (leveraging significant revenue benefits but giving up the associated GHG emission credit)
- B. Use RNG within the City (offsetting natural gas purchase with lower economic benefit, but maintaining GHG emission credit, aligning with Corporate Energy and Sustainability targets)

Fuel cells are an emerging power generation technology that produces electricity and heat from a chemical reaction between hydrogen and oxygen. Hydrogen can be extracted from digester gas feed using a high-pressure reformer, which produces and/or increases the concentration of hydrogen while decreasing the concentration of gas species toxic to fuel cells. Hydrogen production, however, is considered an emerging technology with few full-scale installations, and as a result was not shortlisted for this assessment.

4. Multi-criteria Evaluation Approach

A multi-criteria evaluation approach was used to assess the shortlisted alternatives. The approach includes the following components:

- **Evaluation Criteria and Category:** A set of criteria was developed to compare the features of each alternative, grouped into the following categories:
 - Economic (capital, O&M, carbon tax, revenue, and 20-year life-cycle costs)
 - Non-economic (technical, environmental and social considerations)
- **Category Weights (Non-economic):** Each non-economic category of criteria was assigned a weight that reflects the category's importance relative to other categories. Categories with higher weight will have more impact on the total score and ranking of the alternatives. The total weight of all non-economic categories adds up to 100 percent.
- **Criterion Weights (Non-economic):** Within each non-economic category, each criterion was assigned a weight (between 1 and 5) that reflects the criterion's importance relative to other criteria. Criteria with higher weights will have more impact on the total benefit score and ranking of the alternatives.
- **Criterion Scores (Non-economic):** A score (between 1 and 5) was assigned for each criterion, unique to each alternative, scored on a scale of 1 (most negative impact) to 5 (most benefit or improvement). The score of each criterion was weighted based on the criteria weights and normalized to the category weights in developing the total **benefit score** (out of 100) for each alternative.
- **Category Scores (Non-economic):** A score calculated based on the category weight, criterion weight and criterion score, using the following formula:

$$\text{Category Score} = \frac{(\text{Category Weight} * 100) * \left(\frac{\text{Criterion Weight}}{5} \right) * \text{Criterion Score}}{\sum \text{Criterion Weights within Category}}$$

Where: Category Weight is a percentage out of 100
 Criterion Weight is between 1 and 5
 Criterion Score is between 1 and 5

- **Economic Criteria:** The absolute values (20-year life-cycle cost) are presented for comparative evaluation and weighted based on the lowest net present value (NPV) having a score of 100.
- **Total Score:** This was calculated for each alternative as the total of the benefit and economic scores (where benefit and economic scores have equal weighting) to represent the overall cost-effectiveness of each alternative.

4.1 Non-Economic

Figure 3 presents the category weight and criterion weight distribution. Table 3 summarizes criteria details. The category weightings were selected by Jacobs based on typical weightings from other evaluations and a sensitivity analysis on the category weightings performed.

The Technical Category is divided into seven (7) criteria: performance reliability, operating requirements and complexity, maintenance requirements and complexity, constructability, market resilience, footprint/land use and adaptability to future requirements. Higher criterion weightings were given to O&M requirements and

complexity as these criteria will significantly impact day-to-day operations and maintenance completed by Operations or third party contractors.

The Environmental Category aligns with the City's Corporate Energy and Sustainability Policy – comparing the energy intensity and GHG emissions of alternatives, based on the potential/opportunity to reduce energy consumption and release GHGs. Scores were assigned based on ranking the absolute energy intensities and GHG emissions of the alternatives.

The Social Category encompasses three (3) criteria important to Operations and the community: noise impact, odour impact, and occupational health and safety risk. The occupational health and safety risk was given a slightly higher weighting than the other criteria as unhealthy/unsafe conditions are more difficult to mitigate than noise/odour impacts.

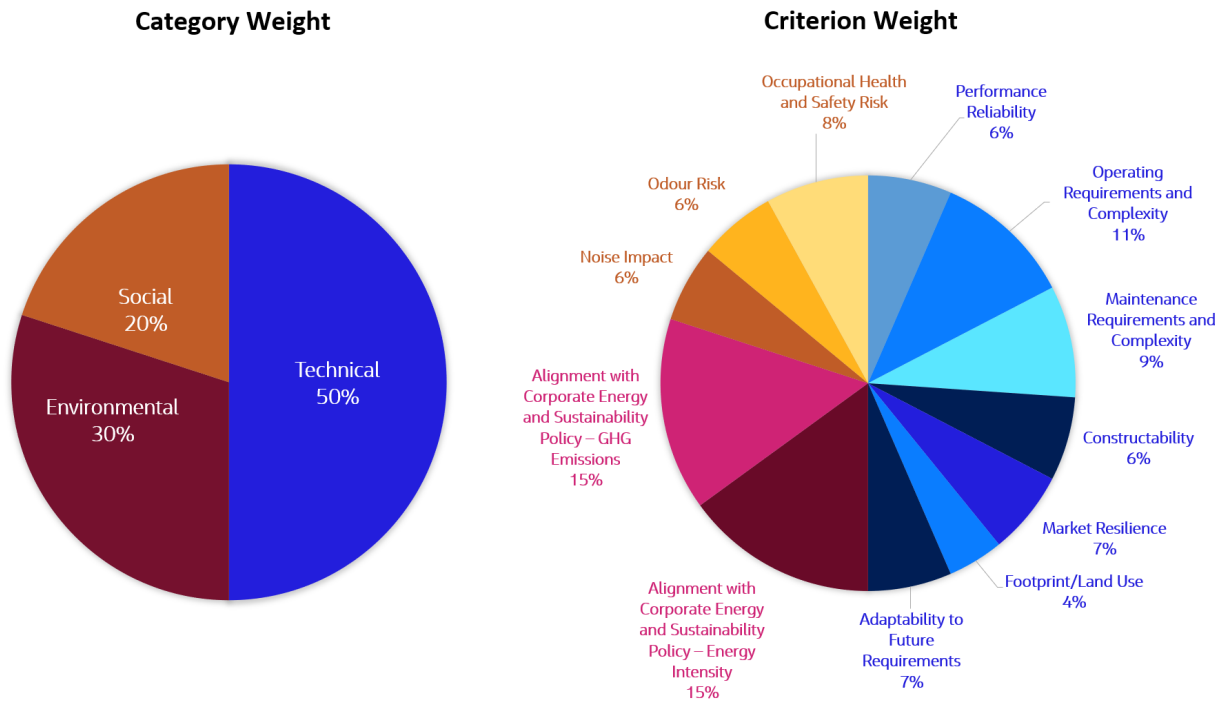

Figure 3. Summary of Category and Criterion Weight Distribution

Table 3. Evaluation Criteria Details

Category/ Weight (%)	Criterion	Criterion Weight (1 to 5)	Potential Max. Category Score	What is Evaluated?
Technical/ 50%	Performance Reliability	3	6.5	Ability to reliably meet regulated performance objectives and criteria
	Operating Requirements and Complexity	5	10.9	Ease of operation and number of process components required, considering the degree of training and experience required for operations staff and number of operators required, and

Category/ Weight (%)	Criterion	Criterion Weight (1 to 5)	Potential Max. Category Score	What is Evaluated?
				certification requirements; impacts on upstream/downstream processes ((e.g., whether a technology requires additional treatment process upstream or downstream)
	Maintenance Requirements and Complexity	4	8.7	Maintenance requirements associated with staffing, training, and equipment, as well as availability of service and replacement parts; impacts on upstream/downstream processes (e.g., whether a technology results in additional maintenance upstream or downstream)
	Constructability	3	6.5	Compatibility with existing system; ease of implementation (e.g., permits and approvals, construction timing); operational risks during construction; interference with other projects
	Market Resilience	3	6.5	Vendor and/or market dependency of technology (e.g., whether the technology is patented or proprietary), associated consumables (e.g., material and equipment replacement), and/or final products (e.g., renewable natural gas from digester gas purification).
	Footprint/Land Use	2	4.3	Estimated footprint: ability to optimize site use efficiency (e.g., by allowing existing processes to be decommissioned and land reclaimed for future use)
	Adaptability to Future Requirements	3	6.5	Ability to be optimized to meet more stringent regulatory requirements in the future (e.g., air emissions); ability to easily expand to increase capacity (e.g., modular design)
Environmental/ 30%	Alignment with Corporate Energy and Sustainability Policy – Energy Intensity	4	15.0	Potential/opportunity to reduce overall corporate energy intensity
	Alignment with Corporate Energy and Sustainability	4	15.0	Potential/opportunity to reduce overall corporate GHG emissions

Category/ Weight (%)	Criterion	Criterion Weight (1 to 5)	Potential Max. Category Score	What is Evaluated?
	Policy – GHG Emissions			
Social/20%	Noise Impact	3	4.6	Impact on noise or attenuation requirement for noise (e.g., from traffic, construction, or equipment operation)
	Odour Risk	3	4.6	Impact on off-site odour risk or treatment requirement for odour control
	Occupational Health and Safety Risk	4	6.2	Potential health and safety impacts to operations staff, considering the potential exposure to odour, noise, dust, and digester gas
100%			100	

4.2 Economic

4.2.1 Capital Cost Basis

Capital costs were estimated by scaling the original BPU and CHP unit capital costs, accounting for 1 percent annual inflation since installation, to match current equipment prices:

- BPU commissioned in 2012 with a supply and installation cost of \$2.5 million, with a capacity of 10,000 m³/d
- CHP unit commissioned in 2006 with a supply and installation cost of \$5.5 million, with a capacity of 15,000 m³/d

The capital cost estimates in this report exclude external funding, representing the most conservative cost estimate to HRPI.

4.2.2 O&M Cost and Revenue Basis

Key to the O&M and revenue for the shortlisted alternatives is the new Federal carbon tax regime, which applies to provinces that do not have a cap-and-trade or equivalent program. The Federal Government has proposed to increase carbon tax by \$10 per tonne per year until 2022 and \$15 per tonne per year thereafter until 2030, reaching \$170 per tonne. Figure 4 shows the projected natural gas rates in Ontario. The federal increase in carbon tax will increase the cost of natural gas and the market value of RNG.

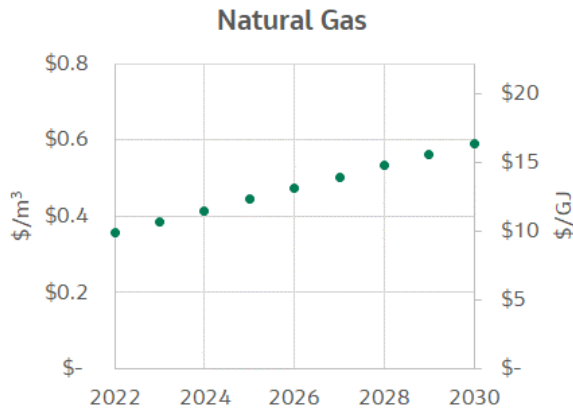

Figure 4. Projected Future Natural Gas Cost (Ontario) with Federal Carbon Tax Regime

Table 4 outlines the O&M and revenue items that have been considered in the economic evaluation of the shortlisted alternatives, based on the year 2025.

Table 4. O&M and Revenue Basis for Evaluation of Shortlisted Alternatives (\$2025)

Item	Unit Cost	Source/Basis
O&M		
BPU labour, maintenance, and electricity	\$7/GJ	Based on historical labour and maintenance costs Includes electricity, service costs and RNG contact costs
CHP labour and maintenance	\$300,000/MWe	Based on historical Toromont and administrative costs for a 1.6 MWe engine
CHP electricity	\$ 0.08/kWh	Per HRPI
Digester gas	\$2.58/GJ (\$2.72/mmBTU)	Per HRPI; part of HRPI's O&M costs
Revenue		
Electricity contract	\$0.08/kWh	Per HRPI
Thermal energy contract	\$11.04/GJ (\$11.65/mmBTU)	Per HRPI
RNG contract with third party	\$25/GJ	Per HRPI
RNG contract with City	\$ 13.40/GJ (\$ 0.48/m³)	Contract rate equivalent to natural gas price, considering Federal carbon tax regime

4.2.3 Life-cycle Cost Basis

A 20-year planning period between 2025 and 2044, carbon tax regime and inflation rate of 2 percent were used for the life-cycle analysis, where applicable (i.e., natural gas pricing based on carbon tax regime and labour, maintenance and electricity based on inflation rate). Contract unit prices were fixed for the full 20-year period and the sensitivity of the unit prices on the results was analyzed.

5. Digester Heating Requirements

5.1 Sludge Heating Demand

To support sludge digestion and the production of digester gas, the sludge in the primary digesters must be heated to 37 degrees Celsius and mixed. Based on the shortlisted alternatives, the sludge can be heated by purchased natural gas fired in the boilers, from thermal energy recovered from cogeneration, or a combination thereof. A seasonal mass balance was established to estimate the total heating requirements for warmer and cooler months. Table 5 presents this analysis.

Table 5. Digester Heating Requirements

Month	Sludge Temp.	Sludge Heating Requirement		Digester Heat Loss			Total Heating Requirement	
	(°C)	(GJ/d)	(MWh/d)	(°C loss/d/kg)	(GJ/d)	(MWh/d)	(GJ/d)	(MWh/d)
Jan	15.8	107	30	1	97	27	204	57
Feb	14.2	115	32	1	97	27	212	59
Mar	13.7	118	33	1	97	27	214	60
Apr	14.6	113	31	1	97	27	210	58
May	17.6	98	27	1	97	27	195	54
Jun	20.2	85	24	1	97	27	181	50
Jul	22.1	75	21	0.3	29	8	104	29
Aug	24.5	63	18	0.3	29	8	92	26
Sep	25.1	60	17	0.3	29	8	89	25
Oct	23.4	69	19	0.3	29	8	98	27
Nov	20.8	82	23	0.3	29	8	111	31
Dec	17.3	100	28	0.3	29	8	129	36

Basis

- From the Wastewater Treatment Facilities 2016 Annual Report (City of Hamilton, 2017):
 - Influent flow: 291 ML/d
 - Influent wastewater temperatures
 - TRS flow rate: 21,103 m³/month
 - TRS total solids (TS): 6.3%
 - TRS volatile solids (VS): 73.0%
 - TWAS flow rate: 15,592 m³/month
 - TWAS TS: 4.7%
 - TWAS VS: 77.7%
- From Sewage ECA 9410-B65QRT dated May 14, 2019 (MECP, 2019):
 - Total primary digester volume: 31,478 m³
- Constants:
 - Specific heat capacity of sludge: 4.18 J/g/°C (typical)

5.2 Cogeneration Thermal Energy Recovery

If cogeneration is implemented in some capacity, thermal energy can be recovered to offset natural gas used by boilers to heat the digesters. Table 6 outlines the potential thermal energy that can be offset from a typical CHP unit, seasonally, and on average. Based on these estimates, during warmer months, it is possible for sludge heating requirements to be fully met by the recovery of thermal energy from CHP if 15,000 m³/d of digester gas is used for cogeneration. Any excess thermal energy can be used to heat buildings.

Table 6. Potential CHP Thermal Energy Available to Offset Natural Gas Purchase for Digester Heating

	Unit	Shortlisted Alternatives				
		1	2	3	4	5
		100% RNG	75% RNG/ 25% CHP	50% RNG/ 50% CHP	25% RNG/ 75% CHP	100% CHP
Digester Gas Use						
RNG Component	%	100	75	50	25	0
CHP Component	%	0	25	50	75	100
Offset Heat Available						
CHP Heat Available to Offset Natural Gas in Digester	GJ/d	0	30	59	89	119
Digester Heating Requirements from January to June						
Digester Sludge Heating Requirement	GJ/d	203	203	203	203	203
Total Natural Gas Digester Heat Requirement	GJ/d	203	173	143	114	84
Digester Heating Requirements from July to December						
Digester Sludge Heating Requirement	GJ/d	104	104	104	104	104
Total Natural Gas Digester Heat Requirement	GJ/d	104	74	45	15	-15
Average Digester Heating Requirement						
Digester Sludge Heating Requirement	GJ/d	153	153	153	153	153
Total Natural Gas Digester Heat Requirement	GJ/d	153	124	94	64	35
Basis						
<ul style="list-style-type: none"> ▪ Total digester gas available to HRPI: 15,000 m³/d as per HRPI ▪ Typical energy in digester gas: 22 MJ/ m³ (LHV) ▪ 90 percent uptime for CHP unit ▪ CAT G3520C CHP thermal efficiency: 39.9%; electrical efficiency: 39.8% (Toromont Cat, 2013) 						

6. Energy Intensity

Based on the City's Corporate Energy and Sustainability Policy, energy intensity refers to the energy usage or consumption of a facility or facility operations using a common measure over a specific timeframe. For wastewater treatment plants, this is kWh/ML/d. The energy intensity reduction for each of the alternatives was estimated based on the amount of electrical energy generated by the CHP unit, offsetting the plant's overall electricity consumption. Table 7 summarizes the energy intensity of each scenario.

Table 7. Energy Intensity Reduction Estimate

Parameter	Unit	Scenarios				
		1	2	3	4	5
		100% RNG	75% RNG/ 25% CHP	50% RNG/ 50% CHP	25% RNG/ 75% CHP	100% CHP
Electrical Energy Production	GJ/d	0	30	59	89	118
Electrical Energy Production	kWh/d	0	8,215	16,431	24,646	32,861
Energy Intensity Reduction	kWh/ML/d per annum	0	7,332	14,663	21,995	29,326
Basis						
<ul style="list-style-type: none"> ▪ Plant rated capacity of 409 ML/d ▪ Total digester gas available to HRPI: 15,000 m³/d as per HRPI ▪ Typical energy in digester gas: 22 MJ/ m³ ▪ 90 percent uptime for CHP unit ▪ CAT G3520C CHP thermal efficiency: 39.9%; electrical efficiency: 39.8% (Toromont Cat, 2013) ▪ Electrical energy required for compressing digester gas upstream of the CHP unit is not included in calculations as distinct metered data were not available 						

7. GHG Emissions

GHG emissions are produced when hydrocarbons, such as natural gas and digester gas, are combusted. GHGs include CO₂, methane (CH₄), and nitrous oxides (N₂O). The following lists the potential GHG emission sources related to this evaluation:

- Combustion of natural gas in boilers to heat digester sludge, resulting in mostly CO₂
- Combustion of digester gas and methane slip (from BPU) in flares, resulting in methane release due to incomplete combustion and the release of biogenic CO₂
- Combustion of digester gas in the CHP unit to produce electrical and thermal energy, resulting in mostly biogenic CO₂

7.1 GHG Emissions Estimate

The **total digester sludge heating required** consists of sludge heating and digester heat loss through the digester walls. Both were calculated from first principles based on available plant data (2016 Annual Wastewater Treatment Report), the plant's current sewage ECA (9410-B65QRT dated May14, 2019) and typical thermal loss coefficients. The **natural gas heat required** is equivalent to the balance of digester heat required after all available heat from CHP unit is used. The **GHG emissions** from combusting natural gas and digester gas, were calculated using emission factors from Environment and Climate Change Canada's *2021 National Inventory Report: Greenhouse Gas Sources and Sinks in Canada* (Environment and Climate Change Canada, 2021).

Table 8 summarizes the GHG emission factors associated with different gas utilization methods, including digester gas combustion (e.g., in flare and CHP engine) and un-combusted digester gas (e.g., incomplete combustion in flares, methane slips during digester gas purification process to generate RNG). The emissions were calculated based on the Intergovernmental Panel on Climate Change (IPCC) Guidelines (IPCC, 2006) for CO₂, CH₄ and N₂O emissions, and the associated Global Warming Potentials (GWP; 25 g CO_{2eq}/g CH₄ emission and 298 g CO_{2eq}/g N₂O emission). The portion of CO₂ emission from biogas combustion (approximately 1,200 g CO_{2eq}/m³) does not count towards the total GHG emission because it is considered biogenic. In addition, a GHG credit was included for RNG grid injection to account for the reduced GHG emission from using RNG instead of natural gas, regardless of the end user (i.e., RNG injected to the grid to be used by Woodward Avenue WWTP or other users). Table 9 summarizes the estimated GHG emissions based on these emission factors. Detailed calculations are available in Appendix A.

Table 8. GHG Emission Factors Associated with Natural Gas and Biogas Utilization

Gas	Utilization	GHG Emission Factor	Basis
Natural Gas	Boiler	1,899 g CO ₂ /m ³	Based on complete combustion in boilers (i.e., no slip)
Digester Gas	Flare	151 g CO ₂ /m ³	Based on enclosed type waste gas burners with combustion efficiency of 99% Includes the flaring of digester gas only; the flaring of methane slip from the BPU is estimated as 'RNG generation'
	CHP	1.21 g CO ₂ /m ³	Based on complete combustion in CHP engines (i.e., no slip)
	RNG Generation	151 g CO ₂ /m ³	Based on 1% of RNG slip during the purification process; slipped RNG is captured and combusted in the flare
	RNG Grid Injection Credit	1,869 g CO ₂ /m ³	Based on the biogenic CO ₂ emission from RNG combustion which does not count towards the total emission
Basis			
<ul style="list-style-type: none"> Total digester gas available to HRPI: 15,000 m³/d as per HRPI Typical energy in digester gas: 22 MJ/ m³ Typical energy in natural gas: 36 MJ/m³ 90 percent uptime for BPU and CHP units; flare combusting digester gas during downtime CAT G3520C CHP thermal efficiency: 39.9%; electrical efficiency: 39.8% (Toromont Cat, 2013) 			

Table 9. GHG Emissions Estimate

Parameter	Unit	Scenarios								
		1A	2A	3A	4A	1B	2B	3B	4B	5
		100% RNG	75% RNG/ 25% CHP	50% RNG/ 50% CHP	25% RNG/ 75% CHP	100% RNG	75% RNG/ 25% CHP	50% RNG/ 50% CHP	25% RNG/ 75% CHP	100% CHP
GHG Emissions	tonnes CO ₂ e/d	8	7	5	4	-17	-12	-8	-3	2
GHG Emissions	tonnes CO ₂ e/ML/d per annum	7	6	5	3	-15	-11	-7	-2	2
<p>'A' indicates that RNG is sold to a third party and 'B' indicates that RNG is sold to the City, keeping the RNG grid injection credit</p> <p>Basis</p> <ul style="list-style-type: none"> Plant rated capacity of 409 ML/d Complete combustion in boilers and CHP unit 99 percent flare efficiency 1 percent RNG slip during purification process; slipped RNG is captured and combusted in the flare 										

8. Carbon Intensity

Carbon intensity (CI) is defined as the ratio of GHG emissions associated with the production, transportation, and use of a given fuel to the energy that is displaced by the fuel (RNG, electrical energy, etc.). A traditional gas source like natural gas has a higher carbon intensity than that of digester gas from a wastewater treatment plant. Even further, methane captured from a dairy farm can have a negative carbon intensity.

The Federal government has proposed a Clean Fuel Standard (CFS), which would regulate GHG emissions from fossil fuel suppliers with the aim of making supply cleaner and less polluting overall (Government of Canada, 2021). Regulatory requirements would come into place late 2022. Suppliers can reduce their own emissions associated with the production of fuels or they can purchase credits created by other parties who have reduced the life-cycle emissions of fuels. Carbon intensity is a measure of these life-cycle emissions. The lower the carbon intensity, the lower the life-cycle emissions, the greater the credit.

As a result, the carbon intensity of RNG produced at the Woodward Avenue WWTP is significant in determining the contract price of RNG with a third party. The carbon intensity of RNG however, is not as significant if the RNG is used within the City's corporate framework, such as to fuel fleet vehicles. Corporate-wide environmental benefits would be the focus of such an internal agreement compared to a high negotiation price.

8.1 Carbon Intensity Estimates

The **energy** generated by the BPU was estimated based on the available amount of digester gas, a LHV of 22 MJ/m³, and a 1 percent methane slip rate (captured and flared). The **electrical energy generated** was estimated based on the available amount of digester gas, a LHV of 22 MJ/m³, and a CHP electrical efficiency of 39.8 percent.

The CI for RNG and CHP were estimated individually for each scenario using the following general equation:

$$CI = \text{GHG emissions from renewable energy generated} / \text{total energy value of renewable energy generated}$$

Where: CI is in units of kg CO₂e/ GJ

GHG emissions per amount of energy input to generate renewable energy (electricity or RNG) is in kg CO₂e/d

Renewable energy generated in GJ/d

Table 10 summarizes the combined GHG emission rates, energy produced and the CI for each of the scenarios based on RNG being sold to a third party (i.e., no GHG emission credit).

Table 10. RNG and CHP CI Estimate

Parameter	Unit	Scenarios				
		1	2	3	4	5
		100% RNG	75% RNG/ 25% CHP	50% RNG/ 50% CHP	25% RNG/ 75% CHP	100% CHP
RNG						
GHG Emission Rate	kg CO ₂ e/d	8,103	6,077	4,051	2,026	0
Energy Produced	GJ/d	294	221	147	74	0
CI	kg CO ₂ e/GJ	28	28	28	28	N/A

Parameter	Unit	Scenarios				
		1	2	3	4	5
		100% RNG	75% RNG/ 25% CHP	50% RNG/ 50% CHP	25% RNG/ 75% CHP	100% CHP
CHP						
GHG Emission Rate	kg CO ₂ e/d	0	518	1,036	1,554	2,072
Energy Produced (Electrical)	GJ/d	0	30	59	89	118
CI	kg CO ₂ e/GJ	N/A	18	18	18	18
Combined						
Combined GHG Emission Rate	kg CO ₂ e/d	8,103	6,595	5,087	3,579	2,072
Combined Energy Produced (RNG + CHP)	GJ/d	294	250	206	162	118
Combined CI (RNG + CHP)	kg CO ₂ e/GJ	28	26	25	22	18
Basis						
<ul style="list-style-type: none"> ▪ Based on RNG being sold to a third party (i.e., no GHG emission credit) ▪ Total digester gas available to HRPI: 15,000 m³/d as per HRPI ▪ Typical energy in digester gas: 22 MJ/ m³ ▪ Typical energy in natural gas: 36 MJ/m³ ▪ 90 percent uptime for BPU and CHP units; flare combusting digester gas during downtime ▪ CAT G3520C CHP thermal efficiency: 39.9%; electrical efficiency: 39.8% (Toromont Cat, 2013) ▪ Electrical energy required for compressing digester gas upstream of the CHP unit is not included in calculations as distinct metered data were not available 						

9. Renewable Energy Options Assessment and Recommendation

9.1 Non-Economic Evaluation

A non-economic evaluation was performed based on the criteria and weightings outlined in Section 4. Maximum scores received for each of the scenarios are presented in Table 11. For evaluation details, including rationale for scores, refer to Appendix B.

Of note, the following had the most impact on differing scores between the shortlisted alternatives:

- Operating requirements and complexity:
 - Both BPU and CHP are automated during normal operation; CHP, however, is more complex from an operating and training perspective
 - More difficult to operate/monitor two systems
- Maintenance requirements and complexity
 - BPU has fewer components than CHP, requiring less overall maintenance
 - More difficult to maintain two systems
- Adaptability to future requirements
 - BPU has a more modular design than CHP
- Energy intensity
 - Ranked based on estimated energy intensities detailed in Section 6
 - Since the BPU does not produce electricity, it does not contribute to overall energy intensity reduction within the City
 - The CHP unit produces electricity, reducing the plant's electricity consumption and as a result reducing the City's overall energy intensity
- GHG emissions
 - Ranked based on estimated GHG emissions detailed in Section 7
 - When RNG is sold to a third party, the third party also receives the associated RNG grid injection GHG emissions credit (equivalent to the biogenic emissions from combusting RNG), decreasing the overall environmental score
 - When RNG is used within the City, the City can apply the RNG grid injection GHG emissions credit to the City's overall GHG emissions and improve overall environmental score

Table 11. Technical, Environmental, and Social Evaluation of Shortlisted Alternatives

Category	Criterion	Max. Potential Category Score	Shortlisted Alternatives								
			1A	2A	3A	4A	1B	2B	3B	4B	5
			100% RNG	75% RNG/ 25% CHP	50% RNG/ 50% CHP	25% RNG/ 75% CHP	100% RNG	75% RNG/ 25% CHP	50% RNG/ 50% CHP	25% RNG/ 75% CHP	100% CHP
Technical	Performance Reliability	6.5	5.2	5.2	5.2	5.2	5.2	5.2	5.2	5.2	6.5
	Operating Requirements and Complexity	10.9	10.9	4.3	4.3	4.3	10.9	4.3	4.3	4.3	8.7
	Maintenance Requirements and Complexity	8.7	8.7	3.5	3.5	3.5	8.7	3.5	3.5	3.5	7.0
	Constructability	6.5	5.2	3.9	3.9	3.9	5.2	3.9	3.9	3.9	6.5
	Market Resilience	6.5	5.2	5.2	5.2	5.2	5.2	5.2	5.2	5.2	5.2
	Footprint/Land Use	4.3	4.3	4.3	4.3	4.3	4.3	4.3	4.3	4.3	4.3
	Adaptability to Future Requirements	6.5	6.5	5.2	5.2	5.2	6.5	5.2	5.2	5.2	3.9
Environmental	Energy Intensity	15.0	3.0	6.0	9.0	12.0	3.0	6.0	9.0	12.0	15.0
	GHG Emissions	15.0	3.0	6.0	6.0	9.0	15.0	15.0	12.0	12.0	9.0
Social	Noise Impact	6.0	6.0	4.8	4.8	4.8	6.0	4.8	4.8	4.8	6.0
	Odour Risk	6.0	4.8	4.8	4.8	4.8	4.8	4.8	4.8	4.8	4.8
	Occupational Health and Safety Risk	8.0	6.4	4.8	4.8	4.8	6.4	4.8	4.8	4.8	4.8
Totals, Rounded											
Technical Subtotal		50	46	32	32	32	46	32	32	32	42
Environmental Subtotal		30	6	12	15	21	18	21	21	24	24
Social Subtotal		20	17	14	14	14	17	14	14	14	16
Total		100	69	58	61	67	81	67	67	70	82
'A' indicates that RNG is sold to a third party and 'B' indicates that RNG is sold to the City, keeping the RNG grid injection GHG emissions credit											

9.2 Economic Evaluation

Table 12 details the capital, O&M costs and revenue associated with each of the shortlisted alternatives, based on the year 2025 and from the perspective of HRPI. The 20-year NPV estimate covers 2025 through 2044.

Table 12. HRPI Life-cycle Costs and Cost Score for Shortlisted Alternatives

	Shortlisted Alternatives				
	1	2	3	4	5
	100% RNG	75% RNG/ 25% CHP	50% RNG/ 50% CHP	25% RNG/ 75% CHP	100% CHP
BPU Capital Costs					
Replace existing CHP unit with a BPU	\$4,268,000	\$3,201,000	\$2,134,000	\$1,067,000	--
CHP Capital Costs					
Replace existing CHP unit with another CHP unit	--	\$1,661,000	\$3,323,000	\$4,984,000	\$6,645,000
Annual BPU O&M Costs					
Digester gas	\$280,000	\$210,000	\$140,000	\$70,000	--
Labour, maintenance, and electricity	\$751,000	\$563,000	\$376,000	\$188,000	--
Annual CHP O&M Costs					
Digester gas	--	\$70,000	\$140,000	\$210,000	\$280,000
Electricity	--	\$19,000	\$38,000	\$58,000	\$77,000
Labour and maintenance	--	\$102,000	\$204,000	\$309,000	\$411,000
BPU Revenue					
A - RNG contract with third party	\$2,683,000	\$2,012,000	\$1,342,000	\$671,000	--
B - RNG contract with City	\$1,438,000	\$1,078,000	\$719,000	\$359,000	--
CHP Revenue					
Electricity contract	--	\$240,000	\$480,000	\$720,000	\$960,000
Thermal energy contract	--	\$119,000	\$239,000	\$358,000	\$478,000
20-y Life-cycle Revenue NPV					
A - RNG sold to third party	\$87,374,000	\$75,899,000	\$64,495,000	\$53,117,000	\$41,662,000
B - RNG used within City	\$54,679,000	\$51,371,000	\$48,135,000	\$44,924,000	
Revenue Score					
A - RNG sold to third party	100	87	74	61	48
B - RNG used within City	63	59	55	51	
'A' indicates that RNG is sold to a third party and 'B' indicates that RNG is sold to the City, keeping the RNG grid injection GHG emissions credit					
Basis					
<ul style="list-style-type: none"> ▪ Capital costs: <ul style="list-style-type: none"> - Existing BPU had a capital cost of \$2.5 million (2012) - Existing Cogeneration Facility had a capital cost of \$5.5 million (2006) - Scenario capital costs scaled based on original BPU and CHP unit costs, inflated by 1 percent per year to match current equipment prices - Engine sizes: 25% CHP – 0.3 MWe; 50% CHP – 0.7 MWe; 75% CHP – 1.0 MWe; 100% CHP – 1.4 MWe 					
Cont'd on next page					

Basis Continued	
▪	Variable O&M costs:
-	2 percent inflation applies to labour, maintenance and electricity
-	BPU labour, maintenance, and electricity at \$7/GJ in 2025
-	CHP labour and maintenance based on \$300,000/MWe (engine size) in 2025
-	CHP unit: 8 percent of engine rating (based on Jacobs' cogeneration project experience)
-	Electricity for operating auxiliary equipment
-	Electricity purchase price: \$0.08/kWh in 2025
▪	Fixed O&M costs:
-	Digester gas contract unit price of \$2.58/GJ (\$2.72/mmBTU)
▪	Revenue:
-	All contract prices are static over 20-year life-cycle
-	RNG third party contract unit price of \$25/GJ
-	RNG City contract unit price of \$13.40/GJ, increasing annually until 2030 with the Federal carbon tax regime
-	Electricity contract unit price of \$0.08/kWh
-	Thermal energy contract unit price of \$11.04/GJ (\$11.65/mmBTU)
-	BPU has 99% purification energy capture; digester gas contains 22 MJ/m ³ of energy
-	CHP units have 39.8% electrical efficiency and 39.9% thermal efficiency based on G3520C
-	100% RNG produces 294 GJ/d of RNG
-	75% RNG produces 221 GJ/d of RNG
-	50% RNG produces 147 GJ/d of RNG
-	25% RNG produces 74 GJ/d of RNG
-	25% CHP produces 342 kWh of electrical energy and 30 GJ/d thermal energy
-	50% CHP produces 684 kWh of electrical energy and 59 GJ/d thermal energy
-	75% CHP produces 1,026 kWh of electrical energy and 89 GJ/d thermal energy
-	100% CHP produces 1,368 kWh of electrical energy and 119 GJ/d thermal energy

The O&M costs at the Woodward Avenue WWTP will also be affected by HRPI's decision to install a BPU or CHP unit, primarily with respect to the amount of natural gas required to heat the digesters. Table 13 summarizes the Wastewater Operations costs (i.e., natural gas) associated with each scenario, accounting for the Federal carbon tax regime increases through 2030.

Table 13. Wastewater Operations Costs for Shortlisted Alternatives

	Shortlisted Alternatives				
	1	2	3	4	5
	100% RNG	75% RNG/ 25% CHP	50% RNG/ 50% CHP	25% RNG/ 75% CHP	100% CHP
Annual natural gas cost (2025) ¹	\$748,000	\$606,000	\$460,000	\$313,000	\$171,000
20-y NPV natural gas cost ¹	\$19,643,000	\$15,914,000	\$12,080,000	\$8,220,000	\$4,491,000
¹ 2025 – 2030 based on natural gas tax regime					

9.3 Comparison

A revenue comparison (Figure 5) was developed to present the 20-year life-cycle revenue for each of the shortlisted alternatives. Of these alternatives, producing RNG from digester gas and selling to a third party provides HRPI with the greatest revenue opportunities.

The cost savings (i.e., savings in natural gas consumption) realized by the City for each of the alternatives is also an important consideration in the overall decision-making process. The 100% CHP alternative will save the City \$15.15 million over 20 years compared to the 100% RNG alternatives (\$19.64 million - \$4.49 million). Figure 5 presents the difference between the 100% CHP 20-y HRPI total lifecycle revenue plus City natural gas savings and the 100% RNG 20-y HRPI total lifecycle revenue values.

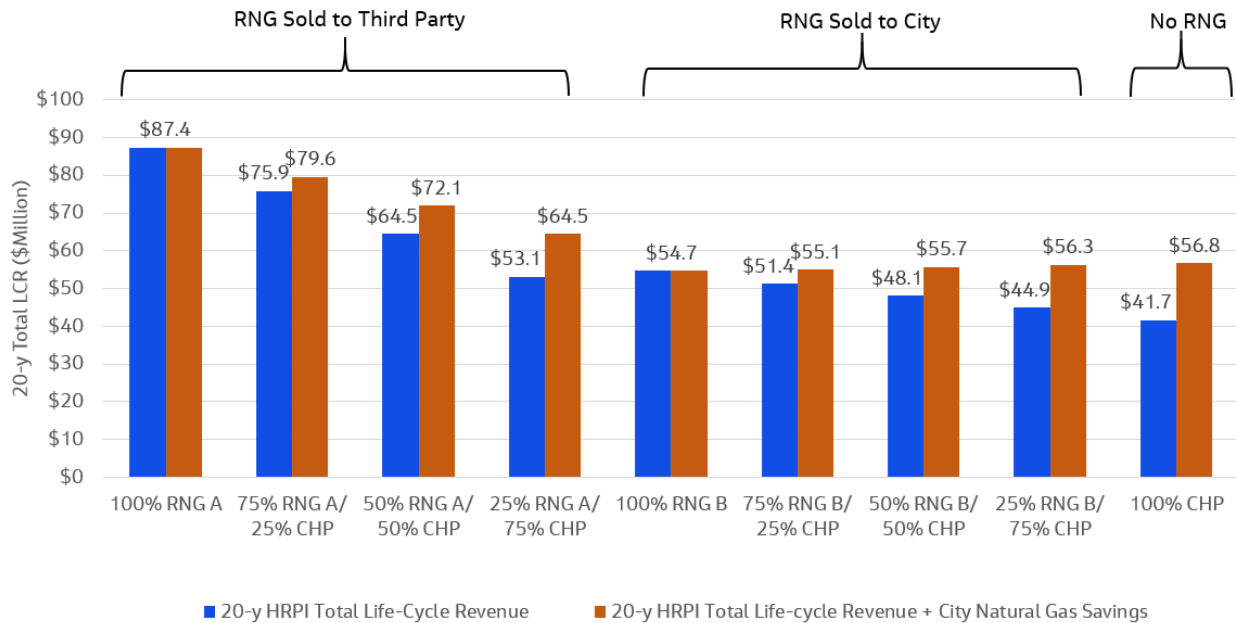

'A' indicates that RNG is sold to a third party and 'B' indicates that RNG is sold to the City

Figure 5. Revenue Comparison of Shortlisted Alternatives

The total scores for shortlisted alternatives, based on the non-economic benefit score and the revenue score being equally weighted, are presented in Figure 6. The 100% RNG alternatives provide the greatest overall benefit to HRPI. When the natural gas savings to the City over the 20-year timeframe are considered, the total score for the 100% CHP alternative increases significantly.

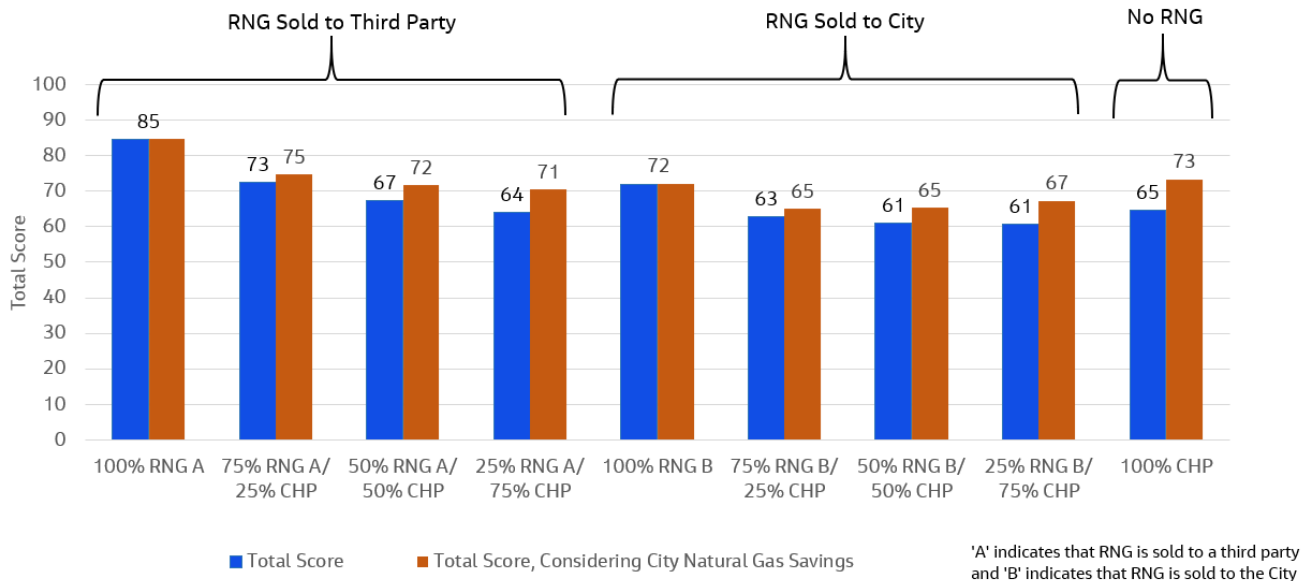

Figure 6. Total Non-Economic and Economic Score of Shortlisted Alternatives

9.4 Sensitivity Analysis

A sensitivity analysis was performed for both non-economic and economic parameters. Details are presented in Appendix C. For the non-economic sensitivity analysis, weightings were changed to better understand their impact on total scores. For the economic sensitivity analysis, RNG and electricity contract prices changed to better understand their impact on total scores. The outcome of this analysis is presented in Table 14 and Figure 7.

The RNG third party contract price strongly factors into total scores. Similarly, the cost of electricity purchase/electricity contract prices strongly factors into total scores. The CHP total score increases in proportion to the electricity unit prices. When the non-economic scores receive more weighting than the economic scores, total scores are expressed in a tighter band (64 to 92 as opposed to the baseline of 63 to 100).

Table 14. Sensitivity Analysis Summary

Scenario	Total Score								
	100% RNG A	75% RNG A/ 25% CHP	50% RNG A/ 50% CHP	25% RNG A/ 75% CHP	100% RNG B	75% RNG B/ 25% CHP	50% RNG B/ 50% CHP	25% RNG B/ 75% CHP	100% CHP
Baseline	100	91	82	74	63	63	64	64	65
All criteria equal weighting	89	78	75	72	74	67	67	68	74
All category equal weighting	83	75	72	71	71	66	66	68	73
High energy intensity weighting	85	75	73	71	69	63	65	67	75
High technical weighting	92	76	73	69	75	64	64	65	74
High social weighting	86	76	73	71	72	66	66	68	73
RNG third party contract price - \$20/GJ	85	71	64	58	73	62	58	55	57
RNG third party contract price - \$30/GJ	85	68	59	51	54	45	43	43	47
Electricity purchase/contract price - \$0.10/kWh	85	71	64	59	60	52	52	53	58
Electricity purchase/contract price - \$0.14/kWh	85	75	73	72	60	56	60	66	75
Low total score economic weighting – 30%	79	67	65	65	76	65	64	65	72
Low total score economic weighting – 40%	82	70	66	65	74	64	62	63	68

'A' indicates that RNG is sold to a third party and 'B' indicates that RNG is sold to the City, keeping the RNG grid injection GHG emissions credit

9.5 Summary and Recommendations

9.5.1 100% RNG

Using digester gas produced on-site at the Woodward Avenue WWTP for RNG production and sale to a third party (100% RNG A) provides the highest combined non-economic and economic score from the perspective of HRPI. From a City perspective, using the RNG within the City (100% RNG B) instead of selling to a third party has less of an economic benefit, however, reduces GHG emissions by almost three-fold (Table 9; 100% RNG A and 100% RNG B produce 7 tonnes CO_{2e}/ML/d per annum and -15 tonnes CO_{2e}/ML/d per annum, respectively).

9.5.2 100% CHP

The 100% CHP alternative helps the City reduce its overall energy intensity by producing electricity to be used at the Woodward Avenue WWTP (Table 7; 29,326 kWh/ML/d). This alternative would also reduce the City's reliance on purchasing natural gas for heating of the digesters, which is scheduled to a price increase in line with the Federal tax regime. During the summer months, the thermal energy recovered from the CHP unit is estimated to offset the entire primary digester heating demand. In the winter months, the thermal energy recovered from the CHP unit is estimated to offset approximately 60 percent of the primary digester heating demand. The 100% CHP alternative would save the City \$15.15 million in natural gas costs over the 20-year life-cycle timeframe compared to either of the 100% RNG alternatives (Table 13). These savings could be captured in the City's digester gas pricing for HRPI. If the City's natural gas savings are considered, the 100% CHP alternative is a more viable option from the perspective of HRPI and the City collectively (Figure 5 and Figure 6).

9.5.3 Recommendations

It is recommended that HRPI further consider other GHG emission reduction initiatives within the City and discuss RNG contract pricing prior to selecting a renewable energy approach for the use of the digester gas at the Woodward Avenue WWTP. Regardless of the alternative selected, it is recommended that HRPI and City consider upsizing BPU/CHP unit equipment capacity beyond 15,000 m³/d to accommodate digester gas projections over the next 20 years. Upsizing would also reduce the amount of digester gas going to flare.

10. References

City of Hamilton. (2017). *Wastewater Treatment Facilities 2016 Annual Report*.

City of Hamilton. (2020). *Corporate Energy and Sustainability Policy*.

City of Hamilton. (2021, June 29). *Climate Change Action*. Retrieved from <https://www.hamilton.ca/city-initiatives/strategies-actions/climate-change-action>

Environment and Climate Change Canada. (2021). *National Inventory Report 1990 - 2019: Greenhouse Gas Sources and Sinks in Canada*.

Government of Canada. (2021). *What is the clean fuel standard?*. Retrieved from <https://www.canada.ca/en/environment-climate-change/services/managing-pollution/energy-production/fuel-regulations/clean-fuel-standard/about.html#shr-pg0>

IPCC. (2006). *Guidelines for National Greenhouse Gas Inventories; Chapter 2: Stationary Combustion*. Intergovernmental Panel on Climate Change.

MECP. (2019). *ECA 9410-B65QRT*.

Toromont Cat. (2013). *Gas Generator Set Product Ratings Summary*.

Appendix A. GHG Emission Estimates

GHG Emission Calculations

GHG Emission Parameters	
Energy in digester gas	22 MJ/m ³
Energy in natural gas	36 MJ/m ³
Electrical energy produced by 100% CHP	118 GJ/d
RNG produced	294 GJ/d
Amount of digester gas available to HRPI	15,000 m ³ /d
Required NG for 100% RNG	153 GJ/d
Required NG for 100% CHP	35 GJ/d
Days per year	365
Annual downtime	10%
RNG slip	1%
Flare efficiency	99%

GHG Emission Factors Associated with Biogas/Natural Gas Utilization

Utilization	GHG Emission Factor
Flare - Unused Digester Gas	151 g CO ₂ /m ³
RNG Generation - Slip	151 g CO ₂ /m ³
Boiler - NG	1,899 g CO ₂ /m ³
CHP - Digester Gas	1.21 g CO ₂ /m ³
RNG Grid Injection Credit	-1,869 g CO ₂ /m ³

100% RNG									
Direct Emissions	Equipment	Notes	Fuel/ Process	GHG Emission	Activity Data	Emission Factor	Emission Rate	GWP	Annual Emissions
Methane from biogas uncombusted in flare	Flare	10% downtime; enclosed type, 99% flare efficiency	Uncombusted biogas	CH ₄	5,475 m ³ /a	0.60 kgCH ₄ /m ³	3.29 t _{CH4} /a	25	82 t _{CO2eq} /a
Methane from oxidation of biogas in flare			Oxidation of biogas	CH ₄	11.92 TJ/a	1.00 kgCH ₄ /TJ	0.0119 t _{CH4} /a	25	0.30 t _{CO2eq} /a
Nitrous oxide from oxidation of biogas in flare			Oxidation of biogas	N ₂ O	11.92 TJ/a	0.10 kgN ₂ O/TJ	0.00119 t _{N2O} /a	298	0.36 t _{CO2eq} /a
Methane from oxidation of natural gas in boiler	Boilers	NG feed for digester heating requirements; complete combustion	Oxidation of natural gas	CH ₄	1,552,882 m ³ /a	0.037 gCH ₄ /m ³	0 t _{CO2} /a	25	1 t _{CO2eq} /a
Nitrous oxide from oxidation of natural gas in boiler			Oxidation of natural gas	N ₂ O	1,552,882 m ³ /a	0.035 gN ₂ O/m ³	0 t _{CO2} /a	298	16 t _{CO2eq} /a
Carbon dioxide from oxidation of natural gas in boiler			Oxidation of natural gas	CO ₂	1,552,882 m ³ /a	1.888 gCO ₂ /m ³	2,932 t _{CO2} /a	1	2,932 t _{CO2eq} /a
Methane from biogas uncombusted in flare	RNG	Combustion of 1% methane slip; enclosed type, 99% flare efficiency	Uncombusted biogas	CH ₄	493 m ³ /a	0.60 kgCH ₄ /m ³	0.30 t _{CH4} /a	25	7 t _{CO2eq} /a
Methane from oxidation of biogas in flare			Oxidation of biogas	CH ₄	0.12 TJ/a	1.00 kgCH ₄ /TJ	0.0001 t _{CH4} /a	25	0.00 t _{CO2eq} /a
Nitrous oxide from oxidation of biogas in flare			Oxidation of biogas	N ₂ O	0.00 TJ/a	0.10 kgN ₂ O/TJ	0.00000 t _{N2O} /a	298	0.00 t _{CO2eq} /a
Sub-Total Direct Emissions									2,958 t _{CO2eq} /a 8,103 kg _{CO2eq} /d
Indirect Emissions					Activity Data	Emission Factor	Emission Rate	GWP	Annual Emissions
RNG (CO ₂ e) Emissions Credit - Biogenic Portion (if RNG used within City)					-4,878,225 m ³ /a	1,888 gCO ₂ /m ³	-9,210 t _{CO2} /a	1	-9,210 t _{CO2eq} /a
Sub-Total Indirect Emissions									-9,210 t _{CO2eq} /a -25,233 kg _{CO2eq} /d
Total GHG Emissions									-6,253 t _{CO2eq} /a -17,130 kg _{CO2eq} /d

100% CHP									
Direct Emissions	Equipment	Notes	Fuel/ Process	GHG Emission	Activity Data	Emission Factor	Emission Rate	GWP	Annual Emissions
Methane from biogas uncombusted in flare	Flare	10% downtime; enclosed type, 99% flare efficiency	Uncombusted biogas	CH ₄	5,475 m ³ /a	0.60 kgCH ₄ /m ³	3 t _{CH4} /a	25	82 t _{CO2eq} /a
Methane from oxidation of biogas in flare			Oxidation of biogas	CH ₄	12 TJ/a	1.00 kgCH ₄ /TJ	0 t _{CH4} /a	25	0 t _{CO2eq} /a
Nitrous oxide from oxidation of biogas in flare			Oxidation of biogas	N ₂ O	12 TJ/a	0.10 kgN ₂ O/TJ	0 t _{N2O} /a	298	0 t _{CO2eq} /a
Methane from oxidation of natural gas in boiler	Boilers	NG feed for digester heating requirements; complete combustion	Oxidation of natural gas	CH ₄	351,393 m ³ /a	0.037 gCH ₄ /m ³	0 t _{CO2} /a	25	0 t _{CO2eq} /a
Nitrous oxide from oxidation of natural gas in boiler			Oxidation of natural gas	N ₂ O	351,393 m ³ /a	0.035 gN ₂ O/m ³	0 t _{CO2} /a	298	4 t _{CO2eq} /a
Carbon dioxide from oxidation of natural gas in boiler			Oxidation of natural gas	CO ₂	351,393 m ³ /a	1.888 gCO ₂ /m ³	663 t _{CO2} /a	1	663 t _{CO2eq} /a
Methane from oxidation of biogas in engine	Engine	Combustion of biogas; complete combustion	Oxidation of biogas	CH ₄	108 TJ/a	1.00 kgCH ₄ /TJ	0.108 t _{CH4} /a	25	2.71 t _{CO2eq} /a
Nitrous oxide from oxidation of biogas in engine			Oxidation of biogas	N ₂ O	108 TJ/a	0.10 kgN ₂ O/TJ	0.0108 t _{N2O} /a	298	3.23 t _{CO2eq} /a
Sub-Total Direct Emissions									756 t _{CO2eq} /a 2,072 kg _{CO2eq} /d
Total GHG Emissions									756 t _{CO2eq} /a 2,072 kg _{CO2eq} /d

Appendix B. Non-Economic Evaluation Matrix

Shortlisted Opportunities - Non-Economic Evaluation

Category Weight (%)	Criterion	Criterion Weight (1 to 5)	Potential Max. Category Score	What is Evaluated?	Opportunities														
					100% RNG			75% RNG/ 25% CHP			50% RNG/ 50% CHP			25% RNG/ 75% CHP			100% CHP		
					Criterion Score (1 to 5)	Weighted Category Score	Rationale	Criterion Score (1 to 5)	Weighted Category Score	Rationale	Criterion Score (1 to 5)	Weighted Category Score	Rationale	Criterion Score (1 to 5)	Weighted Category Score	Rationale	Criterion Score (1 to 5)	Weighted Category Score	Rationale
Technical 50%	Performance Reliability	3.0	6.5	Ability to reliably meet regulated performance objectives and criteria; resilient to process upsets; ability to provide robust performance under flow/loading variations and adverse conditions	4	5.2	BPU performance objectives are more stringent than CHP performance objectives as quality of RNG is critical to supply contract (to third party or within Corporation).	4	5.2	BPU performance objectives are more stringent than CHP performance objectives as quality of RNG is critical to supply contract (to third party or within Corporation).	4	5.2	BPU performance objectives are more stringent than CHP performance objectives as quality of RNG is critical to supply contract (to third party or within Corporation).	4	5.2	BPU performance objectives are more stringent than CHP performance objectives as quality of RNG is critical to supply contract (to third party or within Corporation).	5	6.5	BPU performance objectives are more stringent than CHP performance objectives as quality of RNG is critical to supply contract (to third party or within Corporation).
	Operating Requirements and Complexity	5.0	10.9	Ease of operation and number of process components required, considering the degree of training and experience required for operations staff and number of operators required, and certification requirements; impacts on upstream/downstream processes ((e.g., whether a technology requires additional treatment process upstream or downstream)	5	10.9	Both BPU and CHP are automated during normal operation. CHP however, is more complex from an operating and training perspective. No certification requirements. No impacts to upstream processes.	2	4.3	Both BPU and CHP are automated during normal operation. CHP however, is more complex from an operating and training perspective. No impacts to upstream processes. No certification requirements. More difficult to operate/monitor two systems.	2	4.3	Both BPU and CHP are automated during normal operation. CHP however, is more complex from an operating and training perspective. No impacts to upstream processes. No certification requirements. More difficult to operate/monitor two systems.	2	4.3	Both BPU and CHP are automated during normal operation. CHP however, is more complex from an operating and training perspective. No impacts to upstream processes. No certification requirements. More difficult to operate/monitor two systems.	4	8.7	Both BPU and CHP are automated during normal operation. CHP however, is more complex. No certification requirements. No impacts to upstream processes.
	Maintenance Requirements and Complexity	4.0	8.7	Maintenance requirements associated with staffing, training, and equipment, as well as availability of service and replacement parts; impacts on upstream/downstream processes (e.g., whether a technology results in additional maintenance upstream or downstream)	5	8.7	BPU has fewer components than CHP, requiring less overall maintenance.	2	3.5	BPU has fewer components than CHP, requiring less overall maintenance. More difficult to maintain two systems.	2	3.5	BPU has fewer components than CHP, requiring less overall maintenance. More difficult to maintain two systems.	2	3.5	BPU has fewer components than CHP, requiring less overall maintenance. More difficult to maintain two systems.	4	7.0	BPU has fewer components than CHP, requiring less overall maintenance.
	Constructability	3.0	6.5	Compatibility with existing system; ease of implementation (e.g., permits and approvals, construction timing); operational risks during construction; interference with other projects	4	5.2	New BPU required. Decommissioning of CHP required. Air ECA permit will require updating.	3	3.9	New BPU required. Replacement of CHP unit required. Air ECA permit will require updating.	3	3.9	New BPU required. Replacement of CHP unit required. Air ECA permit will require updating.	3	3.9	New BPU required. Replacement of CHP unit required. Air ECA permit will require updating.	5	6.5	Replacement of CHP engine and auxiliary equipment, as necessary. Air ECA permit will require updating.
	Market Resilience	3.0	6.5	Vendor and/or market dependency of technology (e.g., whether the technology is patented or proprietary), associated consumables (e.g., material and equipment replacement), and/or final products (e.g., renewable natural gas from biogas purification, fertilizer product from struvite recovery).	4	5.2	Technology is not patented/proprietary. Various equipment vendors on the market. Programming may be proprietary.	4	5.2	Technology is not patented/proprietary. Various equipment vendors on the market. Programming may be proprietary.	4	5.2	Technology is not patented/proprietary. Various equipment vendors on the market. Programming may be proprietary.	4	5.2	Technology is not patented/proprietary. Various equipment vendors on the market. Programming may be proprietary.	4	5.2	Technology is not patented/proprietary. Various equipment vendors on the market. Programming may be proprietary.
	Footprint/Land Use	2.0	4.3	Estimated footprint; ability to optimize site use efficiency (e.g., by allowing existing processes to be decommissioned and land reclaimed for future use)	5	4.3	BPU and CHP require similar footprints.	5	4.3	BPU and CHP require similar footprints.	5	4.3	BPU and CHP require similar footprints.	5	4.3	BPU and CHP require similar footprints.	5	4.3	BPU and CHP require similar footprints.
	Adaptability to Future Requirements	3.0	6.5	Ability to be optimized to meet more stringent regulatory requirements in the future; ability to defer or avoid capacity expansion of existing processes (e.g., by allowing existing infrastructure to accommodate high flows/loadings), or easily expanded to increase treatment capacity (e.g., modular design)	5	6.5	BPU has a more modular design than CHP. Exhaust treatment can be added in future if required.	4	5.2	BPU has a more modular design than CHP. Exhaust treatment can be added in future if required.	4	5.2	BPU has a more modular design than CHP. Exhaust treatment can be added in future if required.	4	5.2	BPU has a more modular design than CHP. Exhaust treatment can be added in future if required.	3	3.9	BPU has a more modular design than CHP. Exhaust treatment can be added in future if required.

Appendix C. Sensitivity Analysis

Non-Economic Sensitivity Analysis

Raw Score		(max)	Raw Criterion Score								
Category	Criterion	5	100% RNG A	75% RNG A/ 25% CHP	50% RNG A/ 50% CHP	25% RNG A/ 75% CHP	100% RNG B	75% RNG B/ 25% CHP	50% RNG B/ 50% CHP	25% RNG B/ 75% CHP	100% CHP
Technical	Performance Reliability	5.0	4	4	4	4	4	4	4	4	5
	Operating Requirements and Complexity	5.0	5	2	2	2	5	2	2	2	4
	Maintenance Requirements and Complexity	5.0	5	2	2	2	5	2	2	2	4
	Constructability	5.0	4	3	3	3	4	3	3	3	5
	Market Resilience	5.0	4	4	4	4	4	4	4	4	4
	Footprint/Land Use	5.0	5	5	5	5	5	5	5	5	5
	Adaptability to Future Requirements	5.0	5	4	4	4	5	4	4	4	3
Environmental	Alignment with Corporate Energy and Sustainability Policy – Energy Intensity	5.0	1	2	3	4	1	2	3	4	5
	Alignment with Corporate Energy and Sustainability Policy – GHG Emissions	5.0	1	2	2	3	5	5	4	4	3
Social	Noise Impact	5.0	5	4	4	4	5	4	4	4	5
	Odour Risk	5.0	4	4	4	4	4	4	4	4	4
	Occupational Health and Safety Risk	5.0	4	3	3	3	4	3	3	3	3

All Criteria Equal Weighting		Weighted Category Score									
Category	Criterion	Max. Weighted Category Score	100% RNG A	75% RNG A/ 25% CHP	50% RNG A/ 50% CHP	25% RNG A/ 75% CHP	100% RNG B	75% RNG B/ 25% CHP	50% RNG B/ 50% CHP	25% RNG B/ 75% CHP	100% CHP
Technical	Performance Reliability	8.3	6.7	6.7	6.7	6.7	6.7	6.7	6.7	6.7	8.3
	Operating Requirements and Complexity	8.3	8.3	3.3	3.3	3.3	8.3	3.3	3.3	3.3	6.7
	Maintenance Requirements and Complexity	8.3	8.3	3.3	3.3	3.3	8.3	3.3	3.3	3.3	6.7
	Constructability	8.3	6.7	5.0	5.0	5.0	6.7	5.0	5.0	5.0	8.3
	Market Resilience	8.3	6.7	6.7	6.7	6.7	6.7	6.7	6.7	6.7	6.7
	Footprint/Land Use	8.3	8.3	8.3	8.3	8.3	8.3	8.3	8.3	8.3	8.3
	Adaptability to Future Requirements	8.3	8.3	6.7	6.7	6.7	8.3	6.7	6.7	6.7	5.0
Environmental	Alignment with Corporate Energy and Sustainability Policy – Energy Intensity	8.3	1.7	3.3	5.0	6.7	1.7	3.3	5.0	6.7	8.3
	Alignment with Corporate Energy and Sustainability Policy – GHG Emissions	8.3	1.7	3.3	3.3	5.0	8.3	8.3	6.7	6.7	5.0
Social	Noise Impact	8.3	8.3	6.7	6.7	6.7	8.3	6.7	6.7	6.7	8.3
	Odour Risk	8.3	6.7	6.7	6.7	6.7	6.7	6.7	6.7	6.7	6.7
	Occupational Health and Safety Risk	8.3	6.7	5.0	5.0	5.0	6.7	5.0	5.0	5.0	5.0
	Technical	58	53	40	40	40	53	40	40	40	50
	Environmental	8	2	3	5	7	2	3	5	7	8
	Social	25	22	18	18	18	22	18	18	18	20
	Total Non-economic Score	100	78	65	67	70	85	70	70	72	83
	Economic Score, from a HRPI and City Perspective		100	91	82	74	63	63	64	64	65
	Total Score		89	78	75	72	74	67	67	68	74

All Category Equal Weighting		Weighted Category Score									
Category	Criterion	Max. Weighted Category Score	100% RNG A	75% RNG A/ 25% CHP	50% RNG A/ 50% CHP	25% RNG A/ 75% CHP	100% RNG B	75% RNG B/ 25% CHP	50% RNG B/ 50% CHP	25% RNG B/ 75% CHP	100% CHP
Technical	Performance Reliability	4.3	3.5	3.5	3.5	3.5	3.5	3.5	3.5	3.5	4.3
	Operating Requirements and Complexity	7.2	7.2	2.9	2.9	2.9	7.2	2.9	2.9	2.9	5.8
	Maintenance Requirements and Complexity	5.8	5.8	2.3	2.3	2.3	5.8	2.3	2.3	2.3	4.6
	Constructability	4.3	3.5	2.6	2.6	2.6	3.5	2.6	2.6	2.6	4.3
	Market Resilience	4.3	3.5	3.5	3.5	3.5	3.5	3.5	3.5	3.5	3.5
	Footprint/Land Use	2.9	2.9	2.9	2.9	2.9	2.9	2.9	2.9	2.9	2.9
	Adaptability to Future Requirements	4.3	4.3	3.5	3.5	3.5	4.3	3.5	3.5	3.5	2.6
Environmental	Alignment with Corporate Energy and Sustainability Policy – Energy Intensity	16.7	3.3	6.7	10.0	13.3	3.3	6.7	10.0	13.3	16.7
	Alignment with Corporate Energy and Sustainability Policy – GHG Emissions	16.7	3.3	6.7	6.7	10.0	16.7	16.7	13.3	13.3	10.0
Social	Noise Impact	10.0	10.0	8.0	8.0	8.0	10.0	8.0	8.0	8.0	10.0
	Odour Risk	10.0	8.0	8.0	8.0	8.0	8.0	8.0	8.0	8.0	8.0
	Occupational Health and Safety Risk	13.3	10.7	8.0	8.0	8.0	10.7	8.0	8.0	8.0	8.0
	Technical	33	31	21	21	21	31	21	21	21	28
	Environmental	17	3	7	10	13	3	7	10	13	17
	Social	33	29	24	24	24	29	24	24	24	26
	Total Non-economic Score	100	66	58	62	68	79	68	68	72	81
	Economic Score, from a HRPI and City Perspective		100	91	82	74	63	63	64	64	65
	Total Score		83	75	72	71	71	66	66	68	73

High Energy Intensity Weighting			Weighted Category Score								
Category	Criterion	Max. Weighted Category Score	100% RNG A	75% RNG A/ 25% CHP	50% RNG A/ 50% CHP	25% RNG A/ 75% CHP	100% RNG B	75% RNG B/ 25% CHP	50% RNG B/ 50% CHP	25% RNG B/ 75% CHP	100% CHP
Technical	Performance Reliability	6.5	5.2	5.2	5.2	5.2	5.2	5.2	5.2	5.2	6.5
	Noise Impact	10.9	10.9	4.3	4.3	4.3	10.9	4.3	4.3	4.3	8.7
	Maintenance Requirements and Complexity	8.7	8.7	3.5	3.5	3.5	8.7	3.5	3.5	3.5	7.0
	Constructability	6.5	5.2	3.9	3.9	3.9	5.2	3.9	3.9	3.9	6.5
	Market Resilience	6.5	5.2	5.2	5.2	5.2	5.2	5.2	5.2	5.2	5.2
	Footprint/Land Use	4.3	4.3	4.3	4.3	4.3	4.3	4.3	4.3	4.3	4.3
	Adaptability to Future Requirements	6.5	6.5	5.2	5.2	5.2	6.5	5.2	5.2	5.2	3.9
Environmental	Alignment with Corporate Energy and Sustainability Policy – Energy Intensity	22.5	4.5	9.0	13.5	18.0	4.5	9.0	13.5	18.0	22.5
	Alignment with Corporate Energy and Sustainability Policy – GHG Emissions	7.5	1.5	3.0	3.0	4.5	7.5	7.5	6.0	6.0	4.5
Social	Noise Impact	6.0	6.0	4.8	4.8	4.8	6.0	4.8	4.8	4.8	6.0
	Odour Risk	6.0	4.8	4.8	4.8	4.8	4.8	4.8	4.8	4.8	4.8
	Occupational Health and Safety Risk	8.0	6.4	4.8	4.8	4.8	6.4	4.8	4.8	4.8	4.8
	Technical	50	46	32	32	46	32	32	32	42	42
	Environmental	23	5	9	14	18	5	9	14	18	23
	Social	20	17	14	14	14	17	14	14	14	16
	Total Non-economic Score	100	69	58	63	69	75	63	66	70	85
	Economic Score, from a HRPI and City Perspective		100	91	82	74	63	63	64	64	65
	Total Score		85	75	73	71	69	63	65	67	75

High Technical Weighting			Weighted Category Score								
Category	Criterion	Max. Weighted Category Score	100% RNG A	75% RNG A/ 25% CHP	50% RNG A/ 50% CHP	25% RNG A/ 75% CHP	100% RNG B	75% RNG B/ 25% CHP	50% RNG B/ 50% CHP	25% RNG B/ 75% CHP	100% CHP
Technical	Performance Reliability	10.4	8.3	8.3	8.3	8.3	8.3	8.3	8.3	8.3	10.4
	Operating Requirements and Complexity	17.4	17.4	7.0	7.0	7.0	17.4	7.0	7.0	7.0	13.9
	Maintenance Requirements and Complexity	13.9	13.9	5.6	5.6	5.6	13.9	5.6	5.6	5.6	11.1
	Constructability	10.4	8.3	6.3	6.3	6.3	8.3	6.3	6.3	6.3	10.4
	Market Resilience	10.4	8.3	8.3	8.3	8.3	8.3	8.3	8.3	8.3	8.3
	Footprint/Land Use	7.0	7.0	7.0	7.0	7.0	7.0	7.0	7.0	7.0	7.0
	Adaptability to Future Requirements	10.4	10.4	8.3	8.3	8.3	10.4	8.3	8.3	8.3	6.3
Environmental	Alignment with Corporate Energy and Sustainability Policy – Energy Intensity	6.0	1.2	2.4	3.6	4.8	1.2	2.4	3.6	4.8	6.0
	Alignment with Corporate Energy and Sustainability Policy – GHG Emissions	6.0	1.2	2.4	2.4	3.6	6.0	6.0	4.8	4.8	3.6
Social	Noise Impact	2.4	2.4	1.9	1.9	1.9	2.4	1.9	1.9	1.9	2.4
	Odour Risk	2.4	1.9	1.9	1.9	1.9	1.9	1.9	1.9	1.9	1.9
	Occupational Health and Safety Risk	3.2	2.6	1.9	1.9	1.9	2.6	1.9	1.9	1.9	1.9
	Technical	80	74	51	51	51	74	51	51	51	67
	Environmental	6	1	2	4	5	1	2	4	5	6
	Social	8	7	6	6	6	7	6	6	6	6
	Total Non-economic Score	100	83	61	63	65	88	65	65	66	83
	Economic Score, from a HRPI and City Perspective		100	91	82	74	63	63	64	64	65
	Total Score		92	76	73	69	75	64	64	65	74

High Social Weighting			Weighted Category Score								
Category	Criterion	Max. Weighted Category Score	100% RNG A	75% RNG A/ 25% CHP	50% RNG A/ 50% CHP	25% RNG A/ 75% CHP	100% RNG B	75% RNG B/ 25% CHP	50% RNG B/ 50% CHP	25% RNG B/ 75% CHP	100% CHP
Technical	Performance Reliability	4.6	3.7	3.7	3.7	3.7	3.7	3.7	3.7	3.7	4.6
	Operating Requirements and Complexity	7.6	7.6	3.0	3.0	3.0	7.6	3.0	3.0	3.0	6.1
	Maintenance Requirements and Complexity	6.1	6.1	2.4	2.4	2.4	6.1	2.4	2.4	2.4	4.9
	Constructability	4.6	3.7	2.7	2.7	2.7	3.7	2.7	2.7	2.7	4.6
	Market Resilience	4.6	3.7	3.7	3.7	3.7	3.7	3.7	3.7	3.7	3.7
	Footprint/Land Use	3.0	3.0	3.0	3.0	3.0	3.0	3.0	3.0	3.0	3.0
	Adaptability to Future Requirements	4.6	4.6	3.7	3.7	3.7	4.6	3.7	3.7	3.7	2.7
Environmental	Alignment with Corporate Energy and Sustainability Policy – Energy Intensity	12.5	3	5	8	10	3	5	8	10	13
	Alignment with Corporate Energy and Sustainability Policy – GHG Emissions	12.5	3	5	5	8	13	13	10	10	8
Social	Noise Impact	12.0	12.0	9.6	9.6	9.6	12.0	9.6	9.6	9.6	12.0
	Odour Risk	12.0	9.6	9.6	9.6	9.6	9.6	9.6	9.6	9.6	9.6
	Occupational Health and Safety Risk	16.0	12.8	9.6	9.6	9.6	12.8	9.6	9.6	9.6	9.6
	Technical	35	32	22	22	22	32	22	22	22	30
	Environmental	13	3	5	8	10	3	5	8	10	13
	Social	40	34	29	29	29	34	29	29	29	31
	Total Non-economic Score	100	72	61	64	69	82	69	69	71	81
	Economic Score, from a HRPI and City Perspective		100	91	82	74	63	63	64	64	65
	Total Score		86	76	73	71	72	66	66	68	73

Sensitivity Analysis - Total Score Summary	Total Non-economic and Economic Score									
	Scenario	100% RNG A	75% RNG A/ 25% CHP	50% RNG A/ 50% CHP	25% RNG A/ 75% CHP	100% RNG B	75% RNG B/ 25% CHP	50% RNG B/ 50% CHP	25% RNG B/ 75% CHP	100% CHP
Baseline	100	91	82	74	63	63	64	64	64	65
All Criteria Equal Weighting	89	78	75	72	74	67	67	68	68	74
All Category Equal Weighting	83	75	72	71	71	66	66	68	68	73
High Energy Intensity Weighting	85	75	73	71	69	63	65	67	67	75
High Technical Weighting	92	76	73	69	75	64	64	65	65	74
High Social Weighting	86	76	73	71	72	66	66	68	68	73

Economic Sensitivity Analysis

Sensitivity Analysis - Total Score Summary, from a HRPI and City Perspective	Total Non-economic and Economic Score									
	Scenario	100% RNG A	75% RNG A/ 25% CHP	50% RNG A/ 50% CHP	25% RNG A/ 75% CHP	100% RNG B	75% RNG B/ 25% CHP	50% RNG B/ 50% CHP	25% RNG B/ 75% CHP	100% CHP
Baseline	100	91	82	74	63	63	64	64	64	65
RNG contract price - \$20/GJ	85	71	64	58	73	62	58	55	55	57
RNG contract price - \$30/GJ	85	68	59	51	54	45	43	43	43	47
Electricity grid/ contract price - \$0.10/kWh	85	71	64	59	60	52	52	53	53	58
Electricity grid/ contract price - \$0.14/kWh	85	75	73	72	60	56	60	66	66	75
Low total score economic weighting - 30%	79	67	65	65	76	65	64	65	65	72
Low total score economic weighting - 40%	82	70	66	65	74	64	62	63	63	68