



Hamilton

COMMITTEE OF ADJUSTMENT

City Hall, 5th floor, 71 Main Street West, Hamilton, ON L8P 4Y5
Telephone (905) 546-2424, ext. 4221, 3935 Fax (905) 546-4202
E-mail: cofa@hamilton.ca

CORRECT NOTICE OF PUBLIC HEARING

Application for Consent/Land Severance

APPLICATION NUMBER: HM/B-21:81

SUBJECT PROPERTY: 83 Melbourne St., Hamilton

You are receiving this notice because you are either:

- Assessed owner of a property located within 60 metres of the subject property
 - Applicant/agent on file, or
 - Person likely to be interested in this application
-

APPLICANT(S): Agent A.J. Clarke & Associates c/o F. Kloibhofer
Owner Joseph Marchese

PURPOSE OF APPLICATION: To permit the conveyance of a parcel of land and to retain a parcel of land for residential purposes.

Severed lands:
7.39m[±] x 46.21m[±] and an area of 341.49m^{2±}

Retained lands:
7.39m[±] x 46.21m[±] and an area of 341.49m^{2±}

**This application will be heard in conjunction with
Minor Variance Application HM/A-21:335**

The Committee of Adjustment will hear this application on:

DATE: Thursday, November 25th , 2021
TIME: 3:30 p.m.
PLACE: Via video link or call in (see attached sheet for details)

To be streamed at
www.hamilton.ca/committeeofadjustment
for viewing purposes only

PUBLIC INPUT

Written: If you would like to submit written comments to the Committee of Adjustment you may do so via email or hardcopy. Please see attached page for complete instructions, including deadlines for submitting to be seen by the Committee.

Orally: If you would like to speak to this item at the hearing you may do so via video link or by calling in. Please see attached page for complete instructions, including deadlines for registering to participate.

MORE INFORMATION

For more information on this matter, including access to drawings illustrating this request:

- Visit www.hamilton.ca/committeeofadjustment
- Call 905-546-CITY (2489) or 905-546-2424 extension 4221, 4130, or 3935
- Email Committee of Adjustment staff at cofa@hamilton.ca

DATED: November 25th, 2021

Jamila Sheffield,
Secretary-Treasurer
Committee of Adjustment

Information respecting this application is being collected under the authority of the Planning Act, R.S.O., 1990, c. P. 13. All comments and opinions submitted to the City of Hamilton on this matter, including the name, address, and contact information of persons submitting comments and/or opinions, will become part of the public record and will be made available to the Applicant and the general public.

CONCEPT SKETCH OF
LOT 66
BLOCK "F"
 REGISTERED PLAN No. 253
 IN THE
CITY OF HAMILTON

SCALE 1:200
 0 5 10 metres
 A. J. CLARKE O.L.S.

MELBOURNE STREET

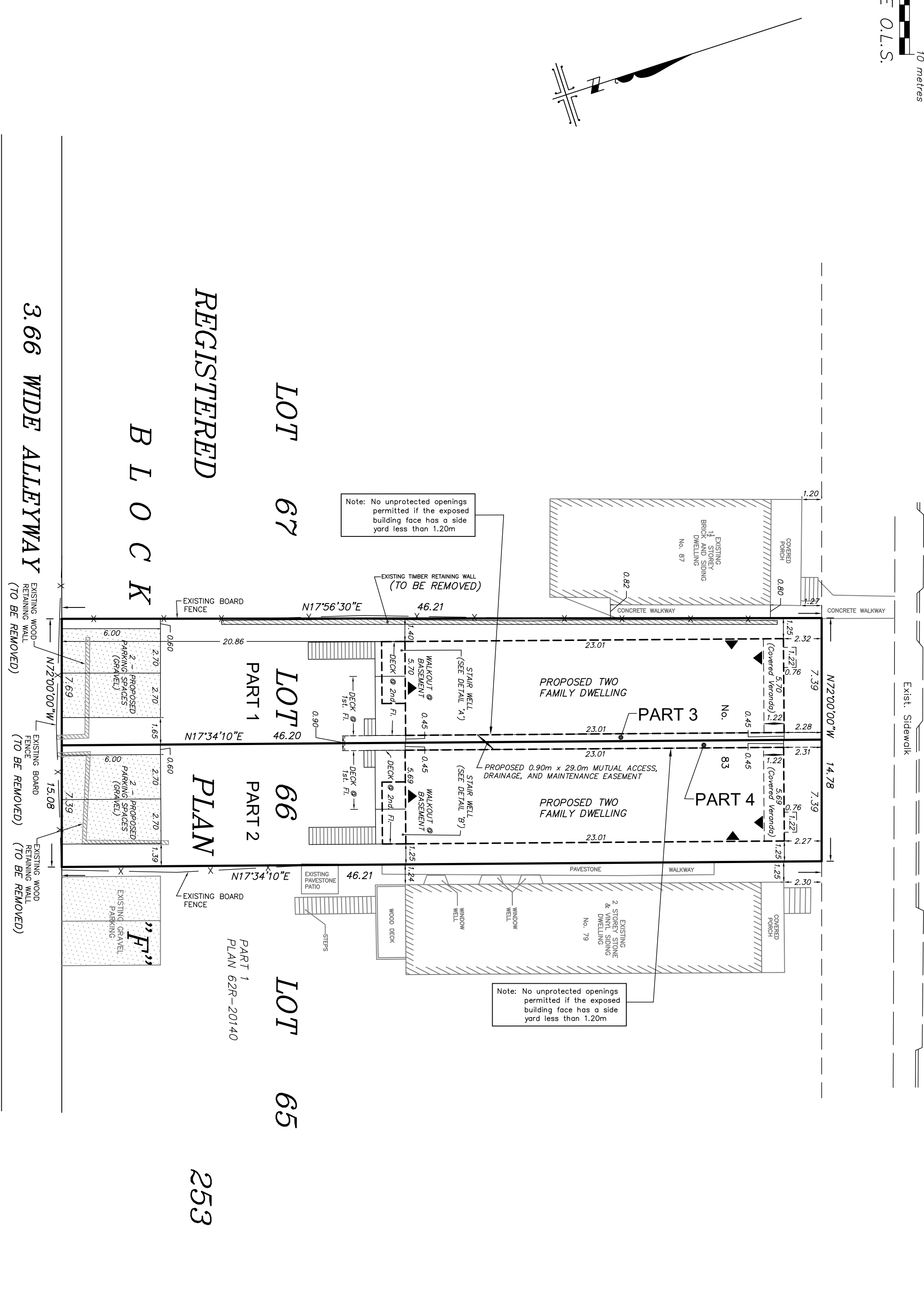

Note: No unprotected openings permitted if the exposed building face has a side yard less than 1.20m

Note: No unprotected openings permitted if the exposed building face has a side yard less than 1.20m

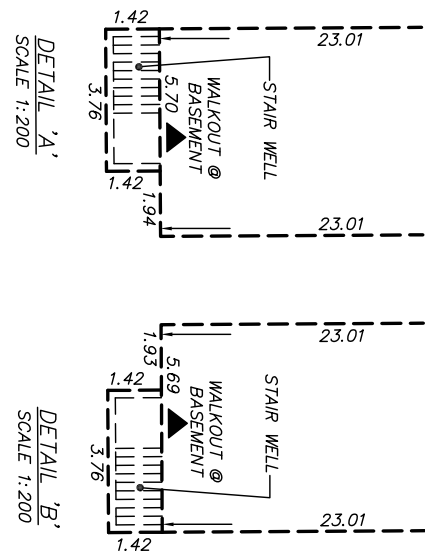
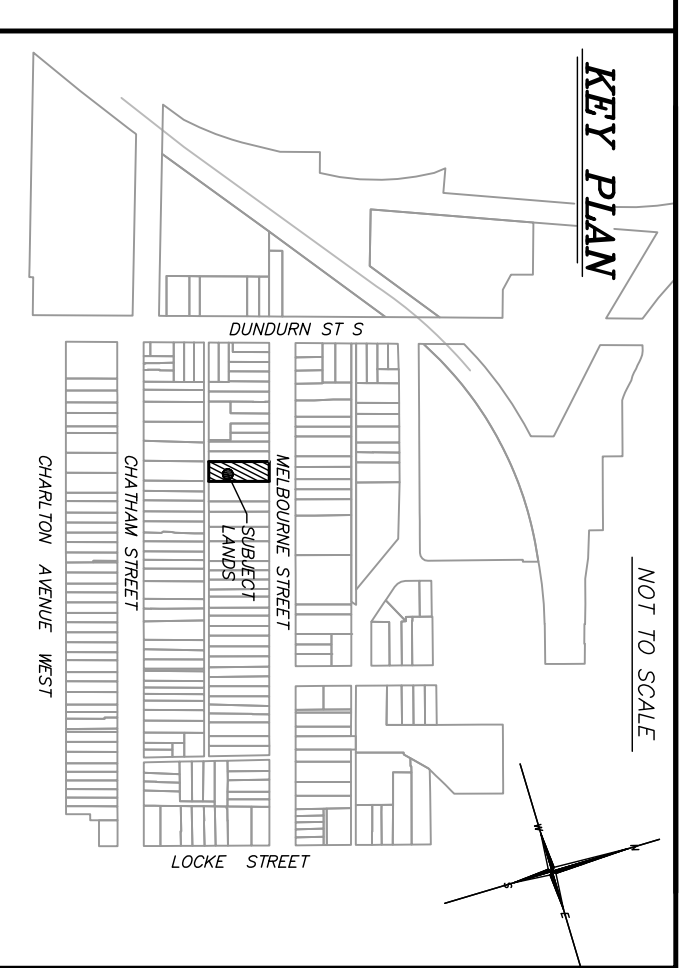

NOTE:
 THE BOUNDARIES AND MEASUREMENTS SHOWN ON THIS SKETCH
 ARE BASED ON A TOPOGRAPHIC SURVEY BY TARASICK MCILLAN KUBICKI LTD.
 DATED JUNE 10, 2021

PROJECT No 218185

A. J. Clarke and Associates Ltd.
 SURVEYORS • PLANNERS • ENGINEERS
 25 MAIN STREET WEST, SUITE 300
 HAMILTON, ONTARIO, L9P 1H1
 TEL. 905-528-8761 FAX 905-528-2289
 email: ajc@ajclarke.com

OCTOBER 18, 2021
 DATE

CONSENT SKETCH OF
LOT 66
BLOCK "F"
 REGISTERED PLAN No. 253
 IN THE
CITY OF HAMILTON

SCALE 1:200
 0 5 10 metres
 A. J. CLARKE O.L.S.

MELBOURNE STREET

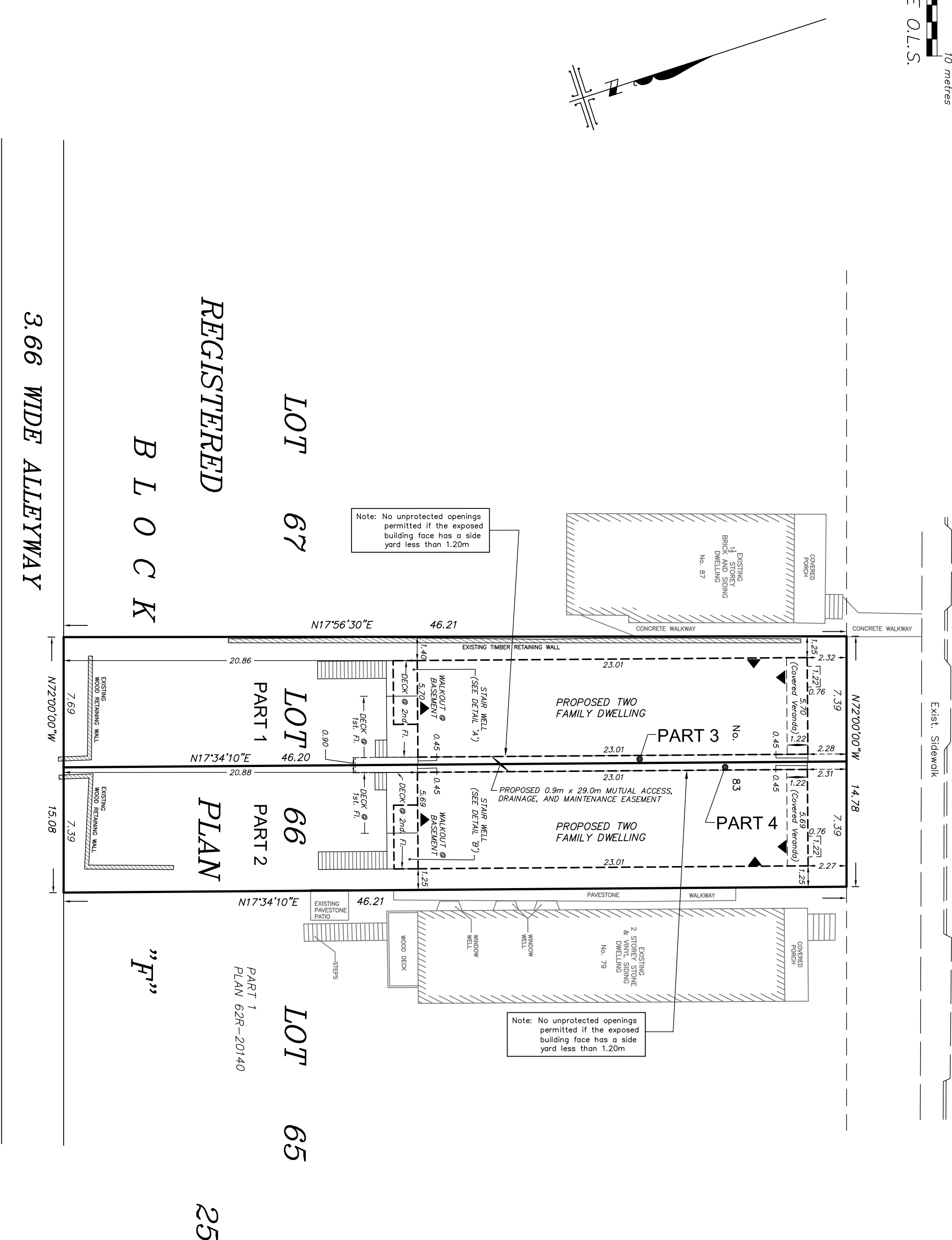

3.66 WIDE ALLEYWAY

REGISTERED
B L O C K

LOT 67

LOT 66
PART 1
PART 2

LOT 65
PART 1
PLAN 62R-20140

"F"

253

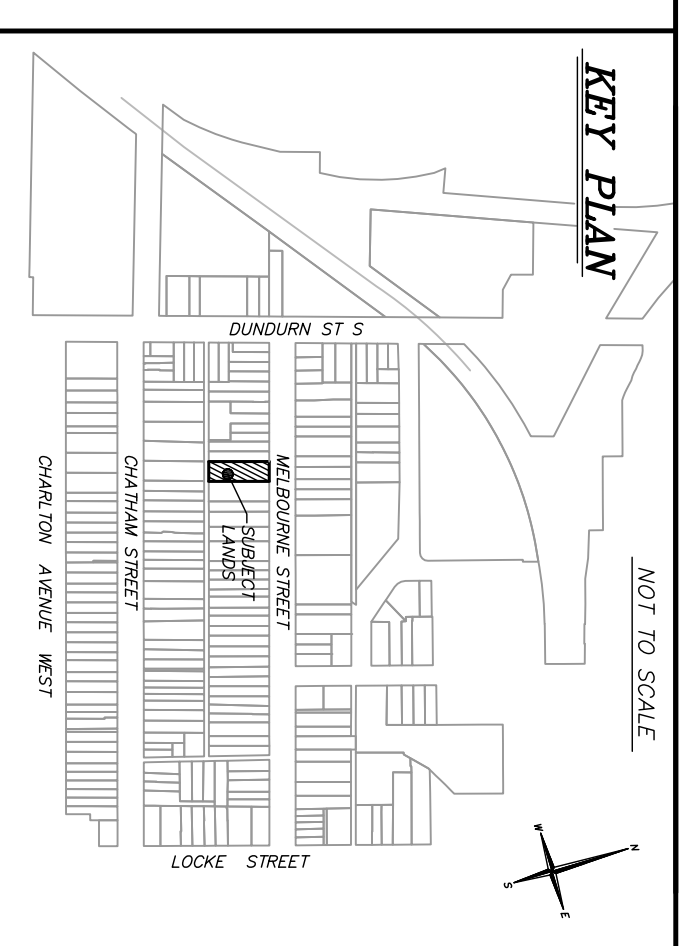

KEY PLAN

NOT TO SCALE

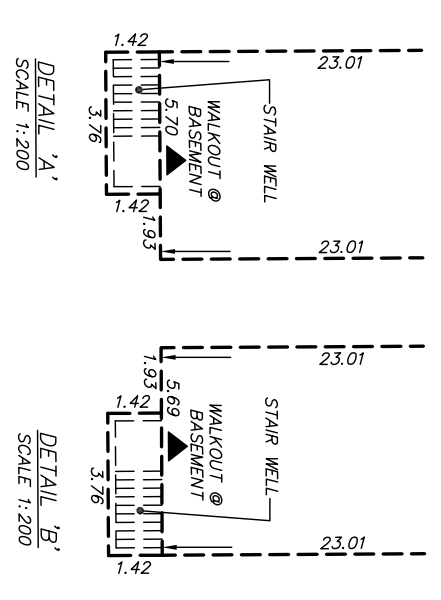

Note: No unprotected openings permitted if the exposed building face has a side yard less than 1.20m

Note: No unprotected openings permitted if the exposed building face has a side yard less than 1.20m

NOTE:
 THE BOUNDARIES AND MEASUREMENTS SHOWN ON THIS SKETCH
 ARE BASED ON A TOPOGRAPHIC SURVEY BY TARASICK MCILLAN KUBICKI LTD.
 DATED JUNE 10, 2021

PROJECT No 218185



A. J. Clarke and Associates Ltd.
 SURVEYORS • PLANNERS • ENGINEERS
 25 MAIN STREET WEST, SUITE 300
 HAMILTON, ONTARIO, L9P 1H1
 TEL. 905-528-8761 FAX 905-528-2289
 email: ajc@ajclarke.com

OCTOBER 18, 2021
 DATE