



Hamilton

COMMITTEE OF ADJUSTMENT

City Hall, 5th floor, 71 Main Street West, Hamilton, ON L8P 4Y5

Telephone (905) 546-2424, ext. 4221

E-mail: cofa@hamilton.ca

NOTICE OF PUBLIC HEARING
Minor Variance

You are receiving this notice because you are either:

- Assessed owner of a property located within 60 metres of the subject property
- Applicant/agent on file, or
- Person likely to be interested in this application

APPLICATION NO.:	HM/A-23:347	SUBJECT PROPERTY:	1036 Garth Street, Hamilton
ZONE:	"C/S-1822" (Urban Protected Residential)	ZONING BY-LAW:	Zoning By-law former City of Hamilton 6593, as Amended

APPLICANTS: Owner: Elvis Klapcic
Agent: Urban in Mind c/o Dorothy Yeung

The following variances are requested:

1. To permit a minimum lot width of 6.6 metres for each individual semi-detached unit, whereas 9.0 metres is required.
2. To permit a minimum lot area of 205 square metres for each individual semi-detached dwelling, whereas 270 square metres is required.

PURPOSE & EFFECT: To create two separate lots for semi-detached dwellings in accordance with land severance application HM/B-24:02.

Notes:

- i. The variances requested of this application are necessary to facilitate lands severance application HM/B-24:02.

This Notice must be posted by the owner of any land which contains seven or more residential units so that it is visible to all residents.

This application will be heard by the Committee as shown below:

DATE:	Tuesday, February 13, 2024
TIME:	2:20 p.m.
PLACE:	Via video link or call in (see attached sheet for details)
	City Hall Council Chambers (71 Main St. W., Hamilton)

	To be streamed (viewing only) at www.hamilton.ca/committeeofadjustment
--	---

For more information on this matter, including access to drawings illustrating this request and other information submitted:

- Visit www.hamilton.ca/committeeofadjustment
- Visit Committee of Adjustment staff at 5th floor City Hall, 71 Main St. W., Hamilton
- Call 905-546-CITY (2489) or 905-546-2424 extension 4221

PUBLIC INPUT

Written: If you would like to submit written comments to the Committee of Adjustment you may do so via email or hardcopy. Please see attached page for complete instructions, written comments must be received no later than February 9, 2024

Orally: If you would like to speak to this item at the hearing you may do so via video link, calling in, or attending in person. Please see attached page for complete instructions, registration to participate virtually must be received no later than February 12, 2024

FURTHER NOTIFICATION

If you wish to be notified of future Public Hearings, if applicable, regarding HM/A-23:347, you must submit a written request to cofa@hamilton.ca or by mailing the Committee of Adjustment, City of Hamilton, 71 Main Street West, 5th Floor, Hamilton, Ontario, L8P 4Y5.

If you wish to be provided a Notice of Decision, you must attend the Public Hearing and file a written request with the Secretary-Treasurer by emailing cofa@hamilton.ca or by mailing the Committee of Adjustment, City of Hamilton, 71 Main Street West, 5th Floor, Hamilton, Ontario, L8P 4Y5.



 Subject Lands

DATED: January 25, 2024

Jamila Sheffield,
Secretary-Treasurer
Committee of Adjustment

Information respecting this application is being collected under the authority of the Planning Act, R.S.O., 1990, c. P. 13. All comments and opinions submitted to the City of Hamilton on this matter, including the name, address, and contact information of persons submitting comments and/or opinions, will become part of the public record and will be made available to the Applicant and the general public, and may include posting electronic versions.



Hamilton

COMMITTEE OF ADJUSTMENT

City Hall, 5th floor, 71 Main Street West, Hamilton, ON L8P 4Y5

Telephone (905) 546-2424, ext. 4221

E-mail: cofa@hamilton.ca

PARTICIPATION PROCEDURES

Written Submissions

Members of the public who would like to participate in a Committee of Adjustment meeting are able to provide comments in writing advance of the meeting. Comments can be submitted by emailing cofa@hamilton.ca or by mailing the Committee of Adjustment, City of Hamilton, 71 Main Street West, 5th Floor, Hamilton, Ontario, L8P 4Y5. **Comments must be received by noon on the date listed on the Notice of Public Hearing.**

Comments are available the Friday prior to the Hearing and are available on our website: www.hamilton.ca/committeeofadjustment

Oral Submissions

Members of the public are also able to provide oral comments regarding Committee of Adjustment Hearing items by participating Virtually through Webex via computer or phone or by attending the Hearing In-person. Participation Virtually requires pre-registration in advance. Please contact staff for instructions if you wish to make a presentation containing visual materials.

1. Virtual Oral Submissions

Interested members of the public, agents, and owners **must register by noon on the day listed on the Notice of Public Hearing** to participate Virtually.

To register to participate Virtually by Webex either via computer or phone, please contact Committee of Adjustment staff by email cofa@hamilton.ca. The following information is required to register: Committee of Adjustment file number, hearing date, name and mailing address of each person wishing to speak, if participation will be by phone or video, and if applicable the phone number they will be using to call in.

A separate registration for each person wishing to speak is required. Upon registering for a meeting, members of the public will be emailed a link for the Webex meeting one business day before the Hearing. Only those registered will be called upon to speak.

2. In person Oral Submissions

Interested members of the public, agents, and owners who wish to participate in person may attend Council Chambers on the date and time listed on the Notice of Public Hearing. Please note, you will be required to provide your name and address for the record. It is advised that you arrive **no less than 10 minutes** before the time of the Public Hearing as noted on the Notice of Public Hearing.

We hope this is of assistance and if you need clarification or have any questions, please email cofa@hamilton.ca or by phone at 905-546-2424 ext. 4221.

Please note: Webex (video) participation requires either a compatible computer or smartphone and an application (app/program) must be downloaded by the interested party in order to participate. It is the interested party's responsibility to ensure that their device is compatible and operating correctly prior to the Hearing.

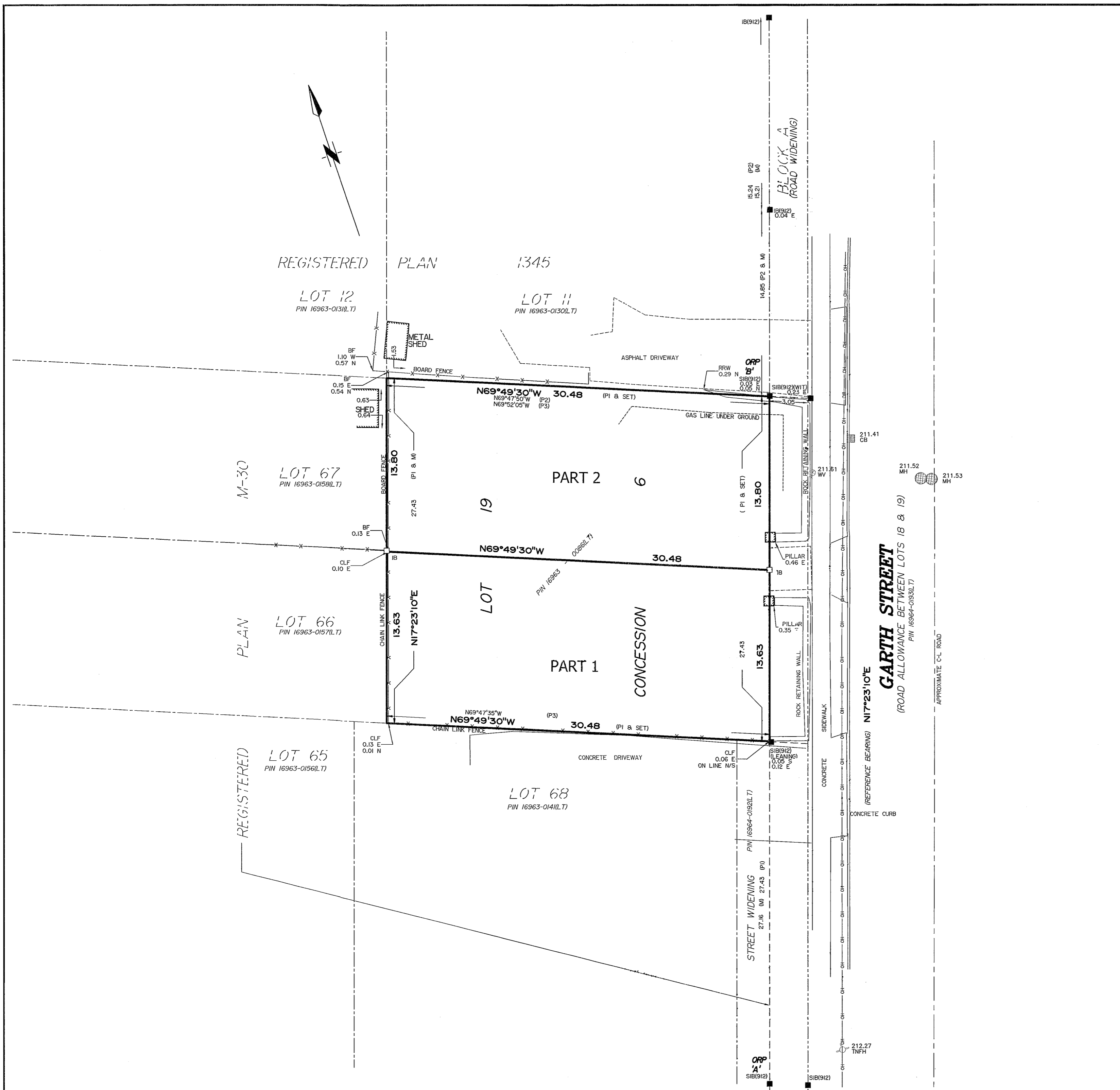

I REQUIRE THIS PLAN TO BE DEPOSITED UNDER THE LAND TITLES ACT.

PLAN 62R-21867

RECEIVED AND DEPOSITED

DATE MARCH 15, 2022

DATE March 17, 2022

HARRY KALANTZAKOS
ONTARIO LAND SURVEYOR

REPRESENTATIVE FOR:
LAND REGISTRAR FOR THE LAND TITLES DIVISION OF WENTWORTH (62)

SCHEDULE			
PART	LOT	PLAN	PIN No.
1	PART OF LOT 19	CONCESSION 6	ALL OF 16963-0086(LT)
2			

THIS PLAN IS COMPRISE OF ALL OF PIN 16963-0086(LT)

PLAN OF SURVEY OF
PART OF LOT 19, CONCESSION 6
GEOGRAPHIC TOWNSHIP OF BARTON
IN THE
CITY OF HAMILTON
SCALE 1 : 200

4 2 0 2 4 6 8 10 METRES

ASHENHURST NOUWENS & ASSOCIATES INC.

INTEGRATION NOTE

UTM ZONE 17, CENTRAL MERIDIAN 81°00' WEST LONGITUDE, NAD83 (CSRS: 2010.0)		
COORDINATES ARE TO AN URBAN ACCURACY PER SEC. 14 (2) OF ONT. REG. 216/10		
POINT ID	NORTHING	EASTING
ORP (A)	4786728.919	589058.600
ORP (B)	4786780.812	589075.544

COORDINATES CANNOT, IN THEMSELVES, BE USED TO RE-ESTABLISH CORNERS OR BOUNDARIES SHOWN ON THIS PLAN

BEARING NOTE
BEARINGS SHOWN HEREON ARE GRID AND ARE DERIVED FROM ORP (A) AND ORP (B) USING REAL TIME NETWORK (RTK) OBSERVATIONS, THE COORDINATES SHOWN HEREON ARE DERIVED FROM THE UNIVERSAL TRANSVERSE MERCATOR SYSTEM (6° UTM PROJECTION) ZONE 17, NAD83 (CSRS: 2010.0)

DISTANCES SHOWN HEREON ARE GROUND DISTANCES AND CAN BE CONVERTED TO GRID DISTANCES BY MULTIPLYING BY A COMBINED SCALE FACTOR OF 0.9996

BEARINGS ON P1, P2 AND P3 HAVE BEEN ROTATED 00°39'50" COUNTER-CLOCKWISE FOR COMPARISONS

METRIC NOTE
DISTANCES AND COORDINATES SHOWN ON THIS PLAN ARE IN METRES AND CAN BE CONVERTED TO FEET BY DIVIDING BY 0.3048.

- LEGEND**
- DENOTES FOUND
 - DENOTES PLANTED
 - IB DENOTES IRON BAR
 - SIB DENOTES STANDARD IRON BAR
 - RIB DENOTES ROUND IRON BAR
 - M DENOTES MEASURED
 - OU DENOTES ORIGIN UNKNOWN
 - WIT DENOTES WITNESS
 - P1 DENOTES REGISTERED PLAN M-30
 - P2 DENOTES REGISTERED PLAN 1345
 - P3 DENOTES PLAN OF SURVEY BY ASHENHURST NOUWENS O.L.S., DATED DECEMBER 5, 2011
 - BF DENOTES BOARD FENCE
 - CLF DENOTES CHAIN LINK FENCE
 - MF DENOTES METAL FENCE
 - MH DENOTES MANHOLE
 - OH DENOTES OVERHEAD UTILITY
 - TNFH DENOTES TOP NUT OF FIRE HYDRANT
 - WV DENOTES WATER VALVE
 - CB DENOTES CATCH BASIN
 - UP DENOTES UTILITY POLE
 - RRW DENOTES ROCK RETAINING WALL
 - 912 DENOTES A. J. CLARKE, O.L.S.
 - ORP DENOTES OBSERVED REFERENCE POINT

SURVEYOR'S CERTIFICATE
I CERTIFY THAT:

- THIS SURVEY AND PLAN ARE CORRECT AND IN ACCORDANCE WITH THE SURVEYS ACT, THE SURVEYORS ACT AND THE LAND TITLES ACT AND THE REGULATIONS MADE UNDER THEM.
- THIS SURVEY WAS COMPLETED ON THE 8TH, DAY OF MARCH, 2022

DATE MARCH 15, 2022

HARRY KALANTZAKOS
ONTARIO LAND SURVEYOR

ASHENHURST NOUWENS & ASSOCIATES INC.
PROFESSIONAL ENGINEERS & ONTARIO LAND SURVEYORS
225 KING WILLIAM STREET, SUITE 204, HAMILTON, ONTARIO L8R 1B1

TELEPHONE: (905) 529-6316
(905) 529-4314
FAX: (905) 529-6651
e-mail: anl@AshenhurstNouwens.ca

DRAWN BY M.S. CALC'D BY W.S. CHK'D BY H.K. FILE No. 21-223 R-PLAN

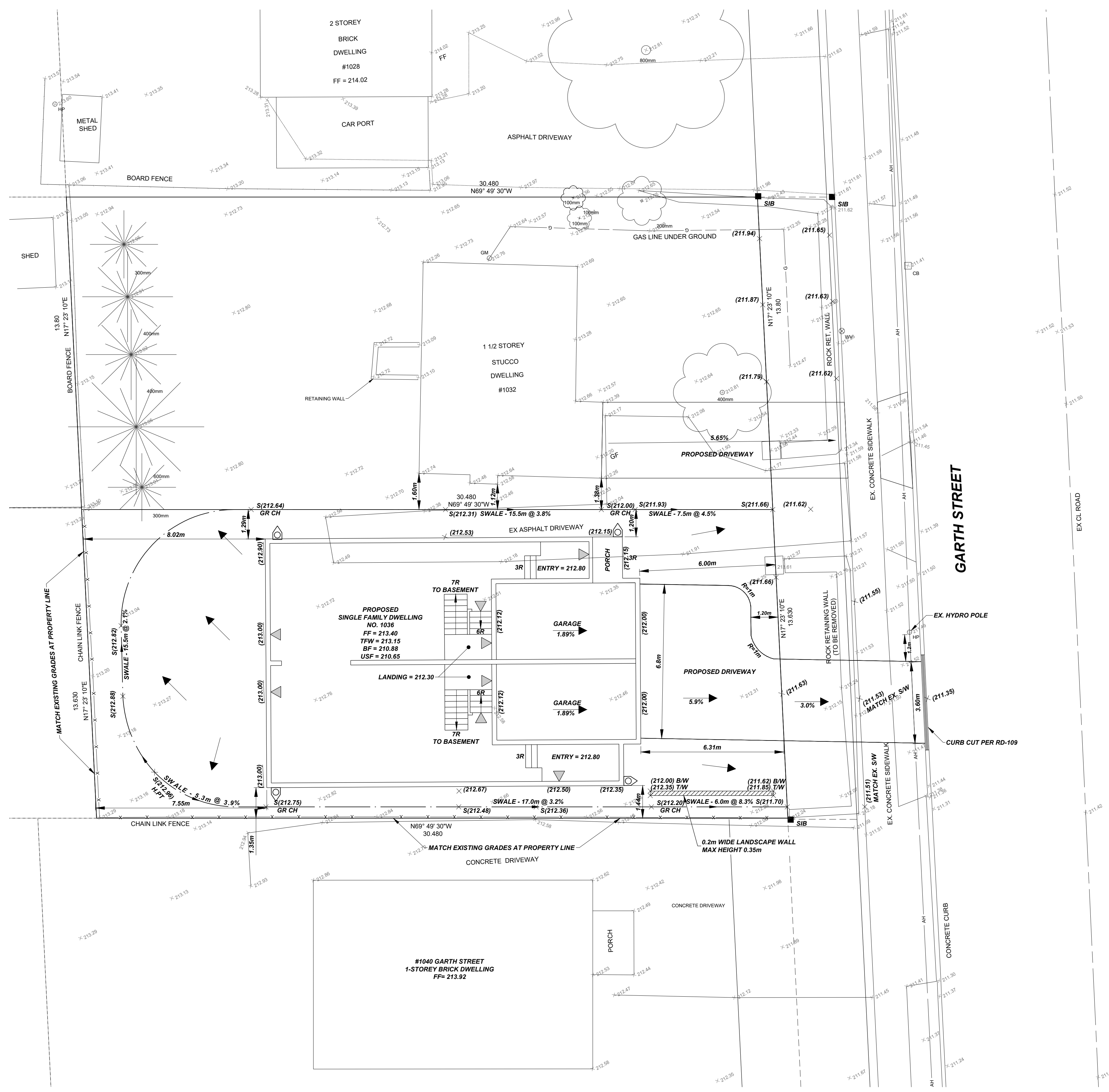

NOTE
BUILDER MUST EXPOSE EXISTING SEWERS AND VERIFY THEIR ELEVATIONS PRIOR TO EXCAVATION/SETTING THE UNDERSIDE OF FOOTING ELEVATION.

NOTE
REFER TO ARCHITECTURAL PLANS FOR STEP FOOTING DETAILS FOR TRANSITION FROM PORCH/GARAGE TO FULL DEPTH FOOTINGS. MINIMUM 1.22m COVER MUST BE PROVIDED IN ALL LOCATIONS.

LEGEND

× 100.50	EXISTING ELEVATION
× 100.00	EXISTING ELEVATION (CALCULATED)
× (100.00)	PROPOSED ELEVATION
× S(100.00)	PROPOSED APRON ELEVATION
× S(100.00)	PROPOSED SWALE ELEVATION
△	PROPOSED DOWNSPOUT
○	PROPOSED ENTRANCE LOCATION
—	PROPOSED SWALE

- GENERAL GRADING NOTES:**
1. MATCH EXISTING GRADE AT PROPERTY / DEVELOPMENT LIMITS WITH SLOTTED SLOPES OF MAXIMUM 3:1 AND/OR RETAINING WALLS AS SPECIFIED.
 2. SLOPES OF SWALES FOR BOTH "BACK-TO-FRONT" AND "SPLIT" DRAINAGE SHALL BE NO LESS THAN 2.0% AND NO GREATER THAN 3% (3:1).
 3. MINIMUM GRADE FOR APRON "WRAP-AROUND" SWALE AT THE REAR OF THE UNIT SHALL BE 1.0%.
 4. WHEN MATCHING TO EXISTING GRADE AT THE LIMITS OF THE DEVELOPMENT / PROPERTY WHERE 2.0% SLOPE CANNOT BE REASONABLY ACHIEVED A 1.5% GRADE IS PERMITTED PROVIDED A 150MM SUB-DRAIN IS INSTALLED WITH THE SWALE AS PER RD-121 AND CONNECTED TO A SUITABLE OUTLET.
 5. DRIVEWAY SLOPES SHALL NOT BE LESS THAN 2.0% AND SHALL NOT BE MORE THAN 7.0%. REVERSED SLOPED DRIVEWAYS ARE NOT ALLOWED FOR ANY NEW CONSTRUCTION.
 6. GARAGE FLOOR ELEVATION SHALL BE SET A MINIMUM OF 0.30M HIGHER THAN THE BACK OF WALK, UNLESS OTHERWISE SPECIFIED.
 7. THE TOP OF FOUNDATION WALL FOR THE DWELLING UNIT SHALL BE A MINIMUM 150MM (6") ABOVE FINISHED GRADE.
 8. UNLESS OTHERWISE NOTED, THE GROUND BETWEEN PROPOSED ELEVATIONS SHALL BE GRADED AS A STRAIGHT LINE.
 9. IF GRADING IS REQUIRED ON LANDS ADJACENT TO THE PROPERTY / DEVELOPMENT WHICH ARE NOT OWNED BY THE DEVELOPER, THEN THE DEVELOPER MUST OBTAIN WRITTEN PERMISSION FROM THE ADJACENT PROPERTY OWNER, OTHERWISE RETAINING WALLS MUST BE USED.
 10. ALL RETAINING WALLS SHALL BE PLACED A MINIMUM 0.45M FROM PROPERTY LINES.
 11. ANY WALL OF GREATER HEIGHT THAN 1.0M MUST BE DESIGNED BY A PROFESSIONAL ENGINEER.
 12. TOP OF RETAINING WALL ELEVATIONS SHALL BE SET A MINIMUM OF 150MM ABOVE THE PROPOSED SIDE-YARD SWALES.
 13. RETAINING WALLS 0.60M AND HIGHER REQUIRE CONSTRUCTION OF A FENCE OR GUARD RAIL AT THE TOP OF THE REAR OF THE WALL. SUCH FENCES OR GUARD RAILS SHALL BE DESIGNED AND CONSTRUCTED IN ACCORDANCE WITH THE REQUIREMENTS OF THE ONTARIO BUILDING CODE.
 14. ALL FILL COMPACTED ON THE LOT(S) SHALL BE COMPACTED TO A MINIMUM 95% SPD (UNLESS OTHERWISE RECOMMENDED BY A GEOTECHNICAL ENGINEER). MATERIALS SHALL BE PLACED IN LIFTS NOT EXCEEDING 300MM DEPTH.
 15. FOR DELINEATION OF TREE PROTECTION ZONES, BUFFERS, REMOVALS, AND PROTECTION SCHEMATICS REFER TO THE TREE PROTECTION PLAN (IF APPLICABLE).

- BACKYARD GRADING NOTES:**
1. "REQUIRED BACKYARD" SHALL BE A MINIMUM OF 6.0 METRES UNLESS OTHERWISE DEFINED IN THE APPLICABLE ZONING BY-LAW.
 2. THE MAXIMUM SLOPE IN THE BACKYARD ADJACENT TO THE BUILDING FOR A DISTANCE EQUAL TO THE REQUIRED BACKYARD SHALL BE 5% EXCEPT FOR SIDE OR REAR YARD SWALES AND RETAINING WALLS.
 3. WHERE THE 5% RESTRICTION ON THE BACKYARD'S GRADES RESULTS IN ELEVATION DIFFERENCES BETWEEN ADJACENT PROPERTIES, RETAINING WALL SHALL BE CONSTRUCTED ALONG THE SIDES AND BACK OF THE LOT.
 4. GENERALLY, SLOPES SHALL BE PLACED ON THE LOWER LOT, WHEREAS RETAINING WALLS SHALL BE PLACED ON THE HIGHER LANDS.
 5. THE 5% RESTRICTION DOES NOT PRECLUDE RETAINING WALLS IN THE REQUIRED BACKYARDS PROVIDING THE TERRACES ARE MAINTAINED TO THE 5% GRADE AS SET OUT ABOVE. THE INTENTION OF THIS PROVISION IS TO PROVIDE FOR FLEXIBILITY OF HOUSE CONSTRUCTION.
 6. BACK TO FRONT DRAINAGE SHALL ONLY BE PERMITTED WHERE THE COMBINED SIDE YARD SETBACK IS 2.0M OR MORE, PROVIDING A MINIMUM OF 2.0m BETWEEN FOUNDATION WALLS FOR DRAINAGE SWALES. A 1.2m SETBACK IS REQUIRED ON THE GARAGE SIDE OF THE LOT.



KEY PLAN **N.T.S.**

BENCHMARK NOTE:
ELEVATION = 208.52 (CGVD28.78)
MONUMENT: 0011965U42
HAMILTON-WENTHWORTH ST. BARTHOLOMEW'S ANGLICAN PARISH HALL, AT SOUTH SIDE OF MOHAWK ROAD, ABOUT 61.0M EAST OF GARTH STREET, OPPOSITE SOUTH END OF WEST 19TH STREET, TABLET IN NORTH CONCRETE FOUNDATION WALL, 30CM FROM NORTHEAST CORNER, 9CM BELOW BRICK, 1.6M ABOVE LEVEL.

- GENERAL NOTES:**
1. TENDERER SHALL SATISFY THEMSELVES AS TO THE NATURE OF THE GROUND AND BID ACCORDINGLY.
 2. ALL ROCK LINE INDICATIONS SHOWN ON THE PLAN MUST BE VERIFIED BY THE CONTRACTOR.
 3. CONTRACTOR SHALL VERIFY LOCATIONS AND INVERTS OF ALL EXISTING SANITARY AND STORM SEWERS AND WATERMANS, PRIVATE DRAINS AND WATER SERVICES, GAS MAINS, CABLE TV, HYDRO AND TELEPHONE DUCTS ETC AT START OF CONSTRUCTION.

NO.	DATE:	DESCRIPTION:
3	2023-06-28	REVISED PER DEV. ENG COMMENTS
2	2023-05-24	REVISED DWY ENTRANCE DUE TO POLE CONFLICT
1	2023-04-12	REVISED PER BUILDING DEPT. COMMENTS
0	2023-03-10	ISSUED FOR BUILDING PERMIT SUBMISSION

SEAL

LandSmith ENGINEERING & CONSULTING LTD.
LANDSMITH ENGINEERING & CONSULTING LTD.
SUITE 302, 3-35 STONE CHURCH RD.
ANCASTER, ON L9K 1S4
ANDREW@LANDSMITHEC.COM
289-775-9374

CLIENT: **ELVIS KLAPCIC**

MUNICIPALITY: **CITY OF HAMILTON**

PROJECT NAME: **1036 GARTH STREET**

TITLE: **GRADING PLAN**

SCALE: 1:100	DATE: 2022-06-06
CHECKED BY: AS	DESIGNED BY: DH
DWG No: 2021C39	SHEET No: G1

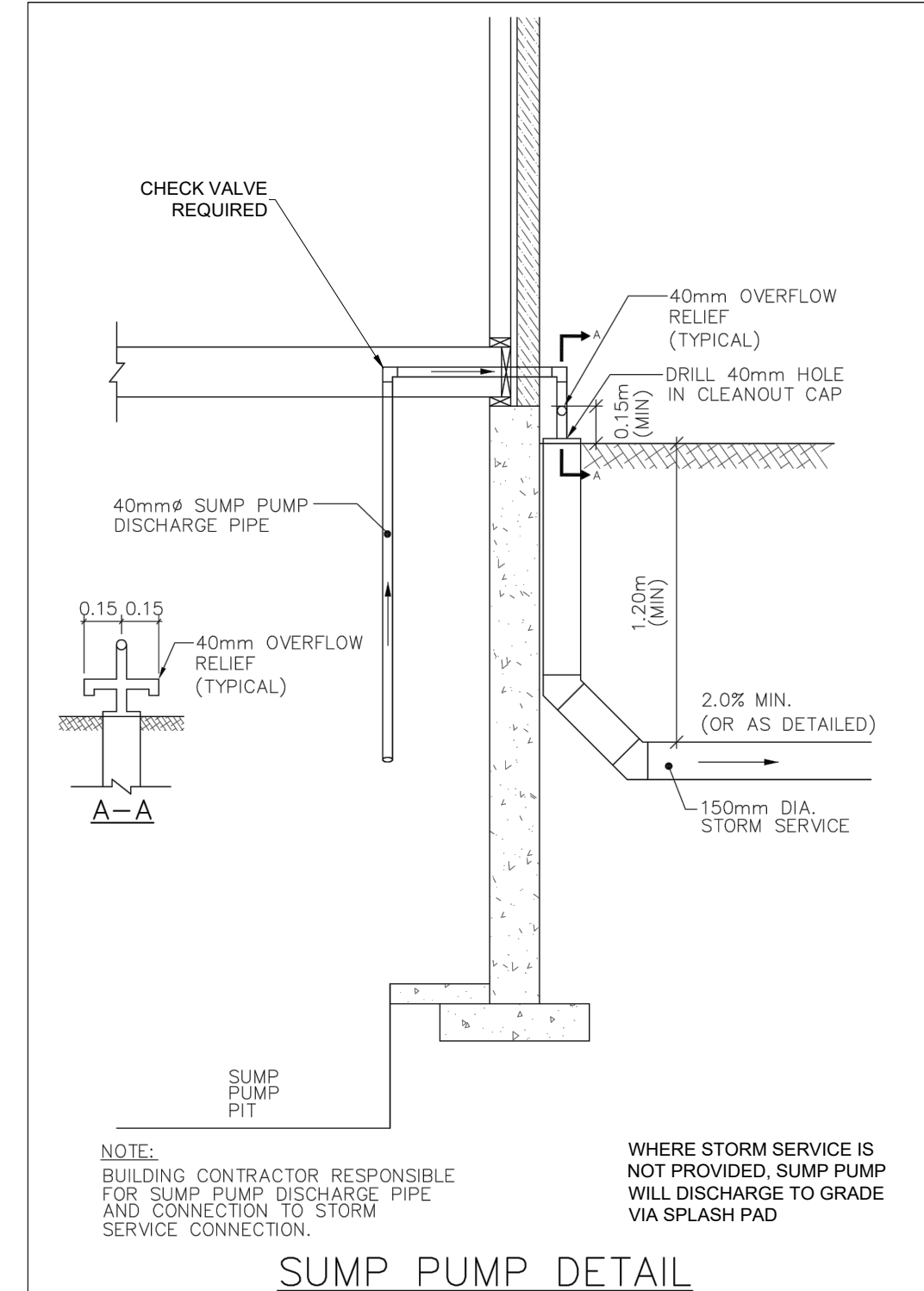

DEVELOPMENT STATISTICS

ADDRESS:	1032 GARTH STREET
ZONING BY-LAW:	CITY OF HAMILTON NO. 22-195 'C' DISTRICT
LOT AREA:	415.0 sq.m
LOT FRONTAGE:	13.63m
FRONT-YARD SETBACK:	6.00m
SIDE-YARD SETBACK:	1.35m (left) / 1.20m (right)
REAR-YARD SETBACK:	7.55m
BUILDING HEIGHT:	2 STOREYS
ASPHALT PARKING AREA:	41.87 sq.m
FRONT YARD LANDSCAPE:	50.1% (6.80m D/W vs 13.63m Lot Width)

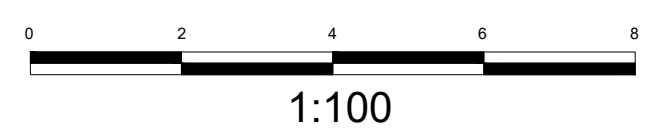
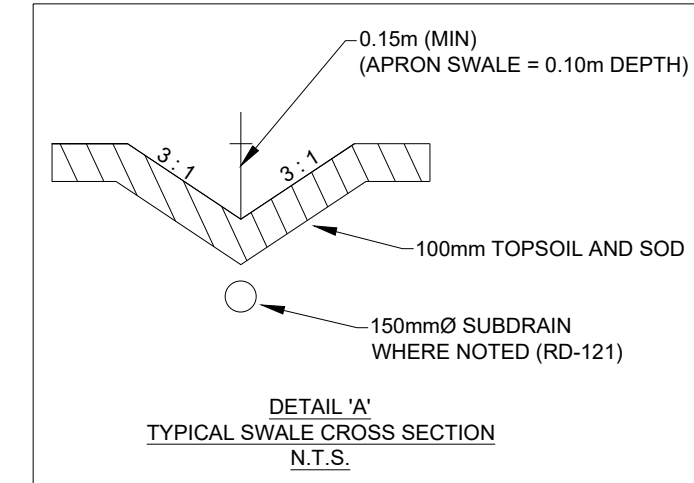

SEVERANCE SKETCH

1036 GARTH STREET
HAMILTON

CURRENT ZONING: C (S-1822)
(ZONING BY-LAW No. 6593)
(ALSO USING BY-LAW No. 22-195)

TOTAL SITE AREA: 415.0 m² (0.10 ac, 0.04 ha)

PROPOSED 2 LOTS WITH SEMI-DETACHED DWELLINGS

	REQUIRED	PROPOSED	
		LOT 1	LOT 2
MIN. LOT AREA	540 m ²	209.5 m ²	205.5 m ²
MIN. LOT WIDTH	18.0 m	6.8 m	6.65 m
MIN. FRONT YARD	6.0 m	6.2 m	6.0 m
MIN. INT. SIDE YARD	1.2 m*	1.35 m*	1.2 m*
MIN. REAR YARD	7.5 m	7.55 m	7.8 m
BUILDING HEIGHT	11.0 m (2 STOREYS)	<11.0 m (=2 STOREYS)	<11.0 m (=2 STOREYS)
DRIVEWAY WIDTH	3.0 m	3.0 m	3.0 m

NOTES:
*INTERIOR SIDE YARD = 0 m (SHARED WALL OF SEMI)

REVISIONS:

THIS DRAWING IS NOT TO SCALE.
FOR DISCUSSION PURPOSES ONLY.

SURVEY INFO FROM LAND SMITH
ENGINEERING & CONSULTING LTD.:
SUITE 332, 3-35 STONE CHURCH
ROAD, ANCASTER, ONTARIO,
289-775-9374,
ANDREW@LANDSMITHEC.COM,
DRAWING #: 2021C39

SCALE:
DATE:
DEC 19, 2023

PROJECT FILE NO.
2023_44
DRAWN BY: J.T.
REVIEWED BY: T.G.

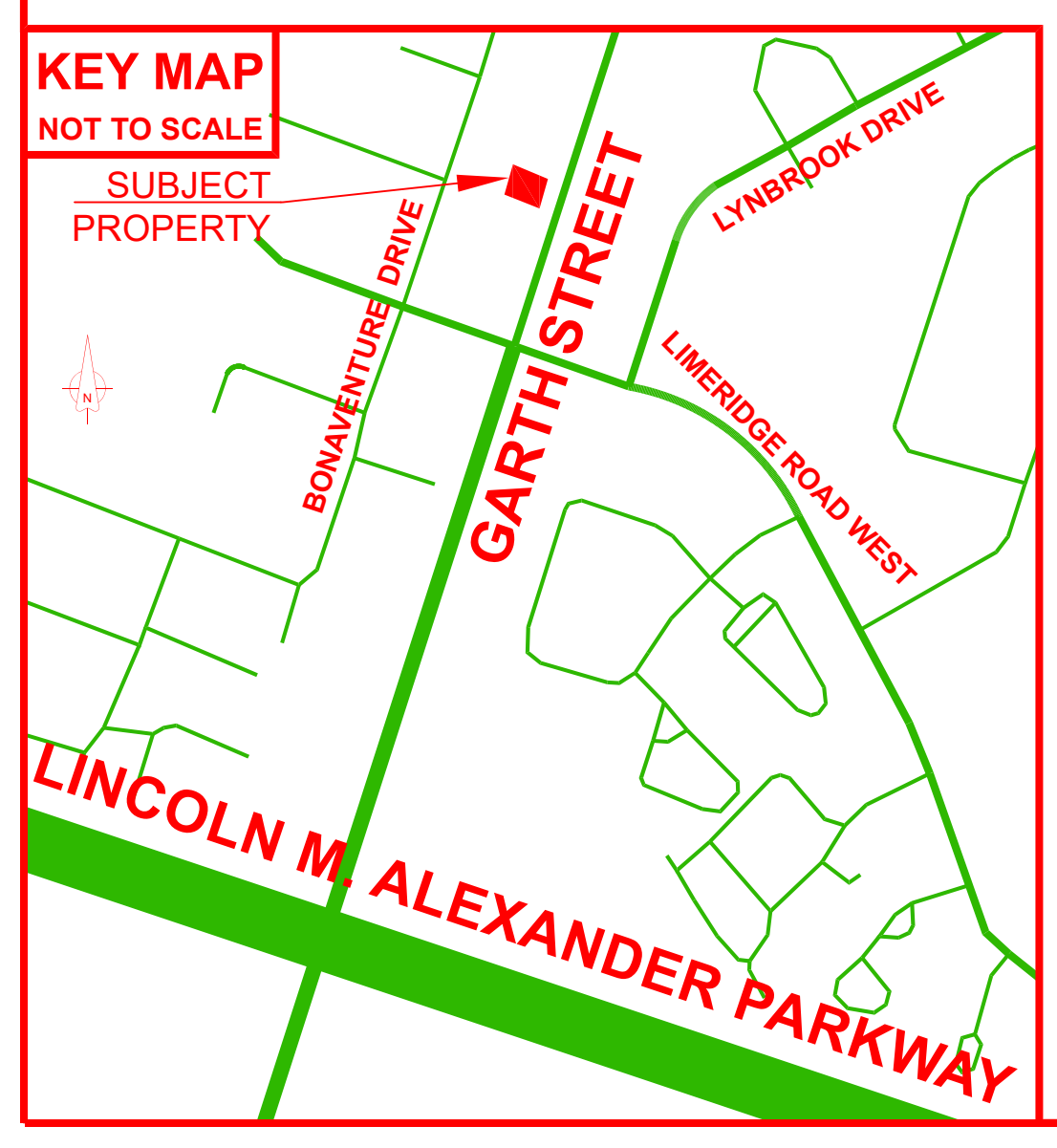
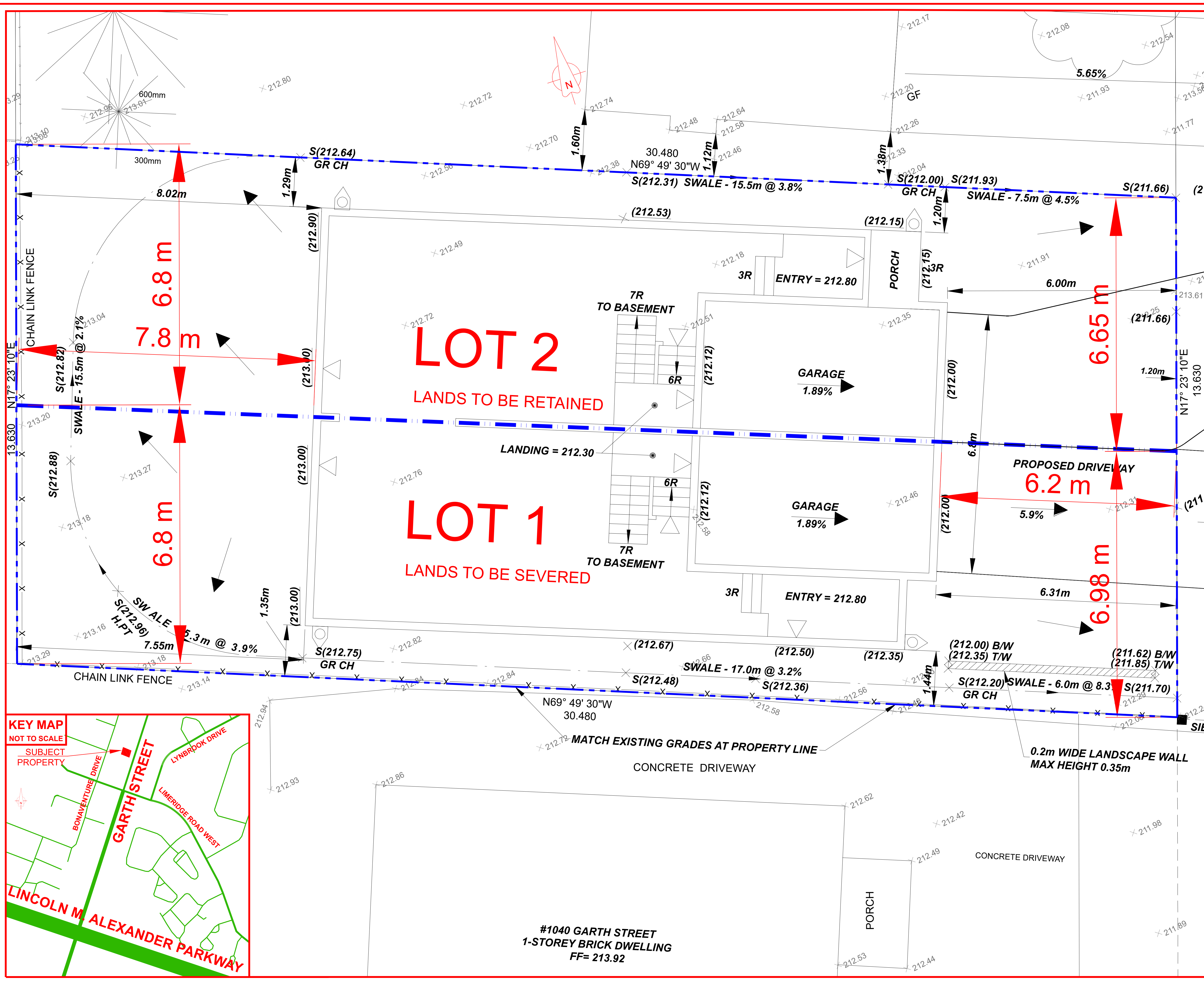

#1040 GARTH STREET
1-STOREY BRICK DWELLING
FF= 213.92



Professional Urban Planning, Land Development & CPTED Consultants

Urban in Mind

3390 South Service Road, Unit #204
Burlington, ON L7N 3J5

www.UrbaninMind.ca

TO: Committee of Adjustment – City of Hamilton

**Re: Minor Variance Application – Cover Letter
1036 Garth Street, Hamilton**

Please see the attached/included Minor Variance Application for the property municipally known as 1036 Garth Street in the City of Hamilton.

Currently, the site is zoned C/S-1822 (as per the City's Zoning By-Law). By-law No. 22-195 permits semi-detached dwellings on "C" lands. The application proposes to amend the lot area and lot width requirements in order to facilitate the development of a semi-detached dwelling.

To this end, I have included the following supporting documents:

- *Application Form*
- *Planning Justification Report*
- *Site Sketch*
- *Survey*

Should you have any questions or difficulties processing this Minor Variance application, please contact the undersigned.

Thank you for your consideration & Best Regards,

Dorothy Yeung, BURPL

Planner/Development Coordinator

Urban in Mind, Professional Urban Planning, Land Development & CPTED Consultants



Planning Justification Report: Minor Variance & Severance

1036 Garth Street, Hamilton

December 22th, 2023

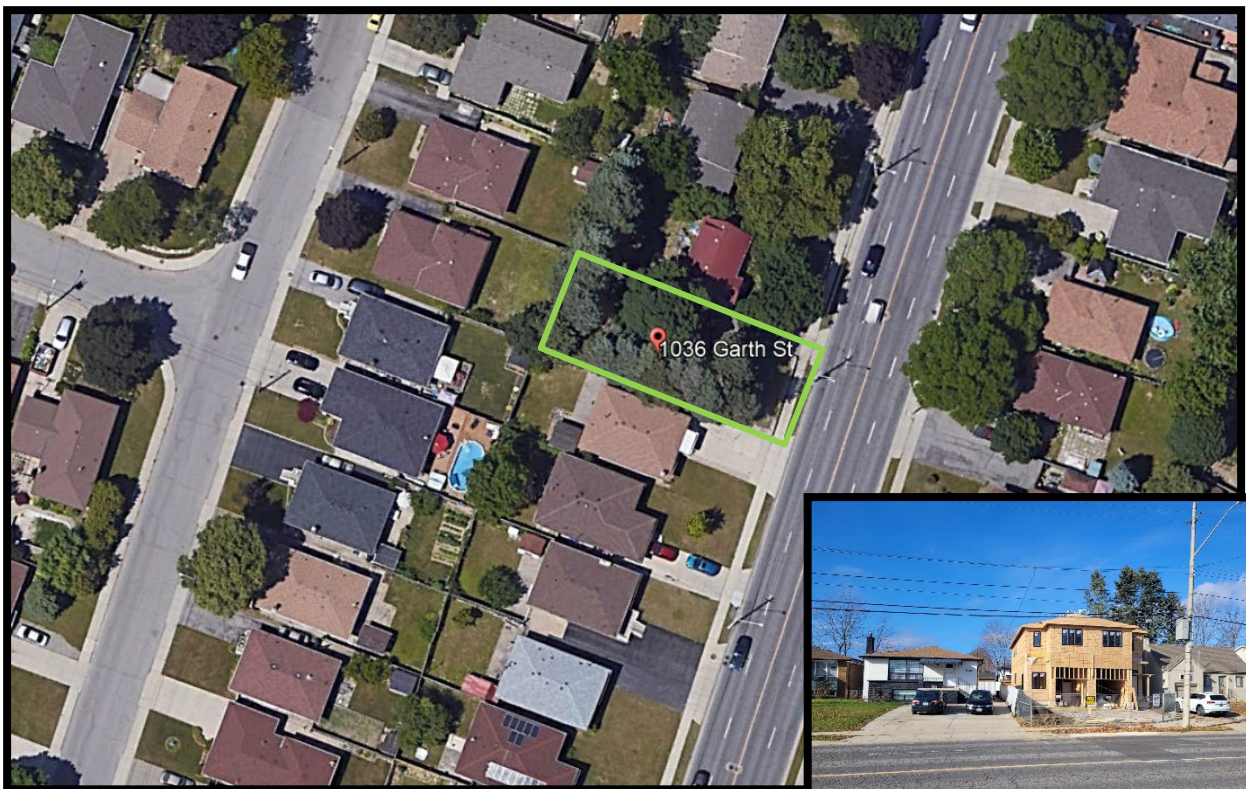

Approx. Subject Property 

Prepared by:
Urban in Mind
Professional Urban Planning, Land Development & CPTED Consultants
www.UrbaninMind.ca
905-320-8120

Contents

1.0	INTRODUCTION.....	3
1.1	Purpose of the Report	3
2.0	SUBJECT PROPERTY AND SURROUNDING AREA	3
2.1	Site Overview	3
2.2	Neighbourhood Character	6
2.3	Transportation	7
3.0	PROPOSED DEVELOPMENT & PLANNING APPLICATION	8
4.0	EXISTING PLANNING POLICY AND REGULATORY FRAMEWORK.....	9
4.1	Planning Act, R.S.O. 1990, c. P.13:	9
4.2	Provincial Policy Statement (2020):	9
4.3	Growth Plan for the Greater Golden Horseshoe (2019):	14
4.4	Greenbelt Plan:.....	17
4.5	Hamilton Conservation Authority (HCA):.....	17
4.6	Urban Hamilton Official Plan (November 2022 Consolidation):	17
4.5	Former City of Hamilton Zoning By-law 6593 (Consolidated 2022):	25
5.0	SEVERANCE JUSTIFICATION.....	28
5.1	Planning Act	28
5.2	Provincial Policy Statement	28
5.3	Growth Plan for the Greater Golden Horseshoe	28
5.4	Urban Hamilton Official Plan.....	29
5.5	Former City of Hamilton Zoning By-law No. 6593	29
5.6	Four Tests of a Minor Variance.....	30
6.0	CONCLUSION	30

List of Figures

Figure 1:	Aerial view of subject property – 1036 Garth Street	4
Figure 2:	Street view of residential and religious institution – South of subject property	4
Figure 3:	Street view of commercial uses and local fire station – North of subject property.....	5
Figure 4:	Street view of William McCulloch Park – West of subject property	5
Figure 5:	Street view of Newlands Park – East of subject property	6
Figure 6:	HSR bus routes near subject property	7
Figure 7:	Concept severance sketch with proposed minor variances	9
Figure 8:	Former City of Hamilton Zoning By-law 6593 Table 1 Minimum Parking Requirements	26
Figure 9:	Permitted uses in Low Density Residential Zones, as Amended by By-law 22-195.....	27

List of Tables

Table 1: Proposed Minor Variances 8

Appendices

Appendix A *Approved Building Permit for 1036 Garth Street* 32
Appendix B *Growth Plan for the Greater Golden Horseshoe – Schedule 4* 33
Appendix C *Greenbelt Plan Area* 34
Appendix D *Hamilton Conservation Authority – Regulated Areas* 35
Appendix E *Urban Hamilton Official Plan – Schedule E-1 – Urban Land Use Designations* 36
Appendix F *Urban Hamilton Official Plan – Appendix F-4 – Archaeological Potential* 37
Appendix G *City of Hamilton Zoning By-law Designations* 38

1.0 INTRODUCTION

Urban in Mind has been retained by the property owner to obtain planning permissions to facilitate the severance of the property municipally known as 1036 Garth Street in the City of Hamilton, Ontario (**Figure 1**) which will be referred to as the “subject property” from hereinafter. Minor variances will be required in order to bring the new lots into conformity with the Former Town of Hamilton Zoning By-law 6593.

Building permissions have already been issued for the development of: “a 2-storey, 307.7m² single detached dwelling. Model: Custom - 4 Bedroom, To install a 32mm water service line, To install a 25mm water meter, To install a 100 mm Diameter Sanitary Building Sewer, and To install a 100 mm Diameter Storm Building Sewer.” (**Appendix ‘A’**)

It is the intention of this Severance and Minor Variance application to facilitate the existing (*currently under construction*) structure to be converted into a semi-detached dwelling with each dwelling on its own separate lot. As a result, the Client is expected to seek an update in the building permit, independently from Urban in Mind, once/if the severance and related minor variances are approved.

1.1 Purpose of the Report

The purpose of this Planning Justification Report is to provide an analysis of the proposed Severance and Minor Variances, and to evaluate the proposal in context with the policies set out in the Planning Act regarding Provincial Interest, Urban Hamilton Official Plan, and current Zoning By-law, thereby providing a sound argument for the approval of the application.

2.0 SUBJECT PROPERTY AND SURROUNDING AREA

2.1 Site Overview

The subject property is municipally known as 1036 Garth Street in the City of Hamilton, Ontario. The subject property (**Figure 1**) is rectangular in shape and has a frontage of 13.63 metres along Garth Street. The approximate total lot area is 415 square metres (0.1 acres / 0.04 hectares).

Currently, the subject property is being constructed as a technical ‘single detached dwelling’, with a built form viewing as a Semi-detached building, which maintains the surrounding neighbourhood character. While many of the homes in the neighbourhood are single detached dwellings, there are a few semi-detached dwellings on Bonaventure Drive, as well as some converted multi-unit dwellings. The subject property is located in an area that can be considered a complete community, where there are options for groceries, restaurants, schools, open recreational space, religious institutions, and a health centre.

The surrounding neighbourhood is an established residential low-density area, and the main options for residential intensification are with infill developments. While the recent development is a result of an infill development, further intensification opportunities are available through the

conversion of a single detached dwelling into a pair of semi-detached dwellings. In addition, the physical building already exists, the question now is, should the existing building (built in a visual form of a semi-detached) be allowed to sever to allow for individual ownerships.

Figure 1: Aerial view of subject property – 1036 Garth Street

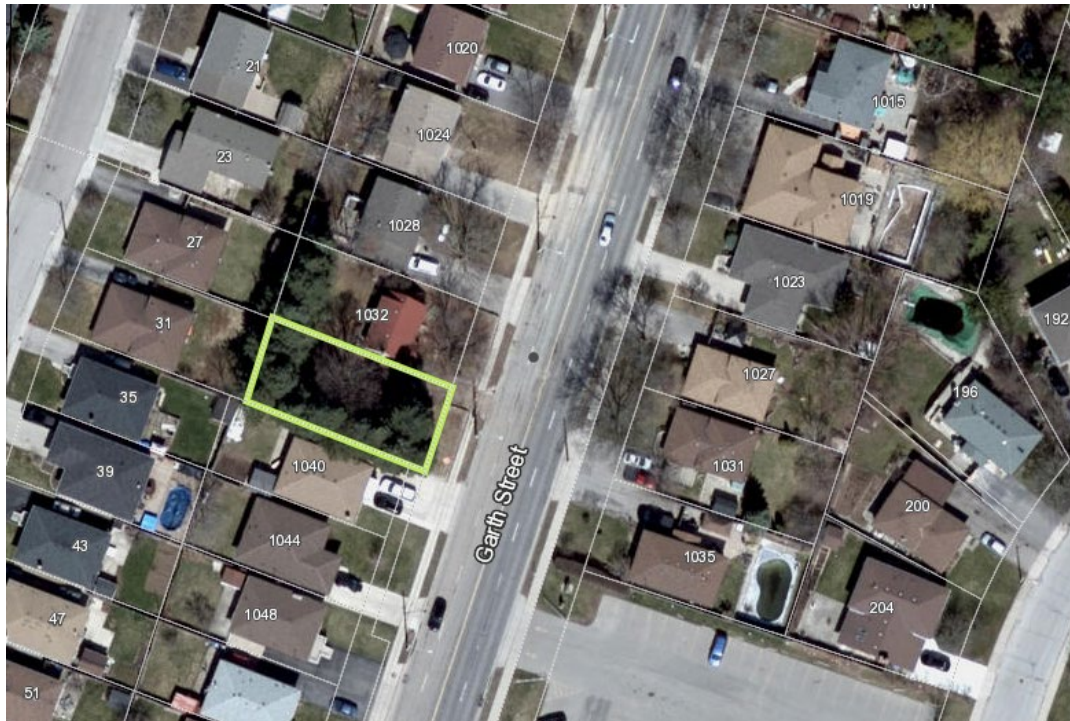

The immediate surrounding area includes the following:

Figure 2: Street view of residential uses and religious institution – South of subject property

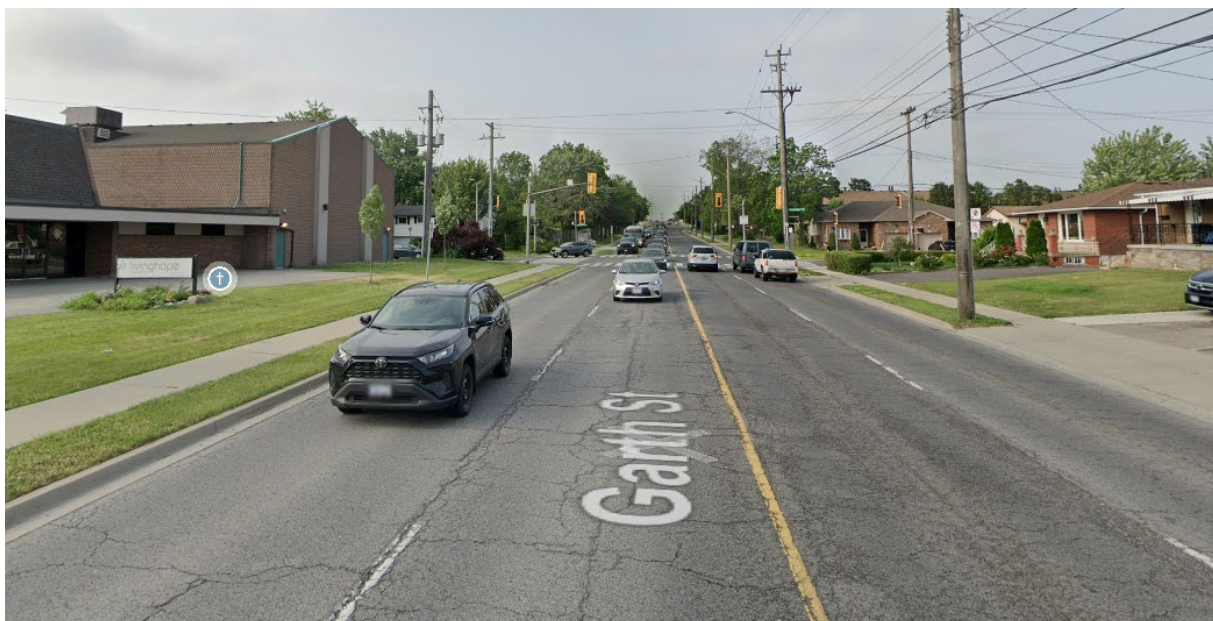

Figure 3: Street view of commercial uses and local fire station – North of subject property



Figure 4: Street view of William McCulloch Park – West of subject property



Figure 5: Street view of Newlands Park – East of subject property



2.2 Neighbourhood Character

The subject property is located within an existing residential area predominantly consisting of low-density residential homes. A mix of single-detached and semi-detached dwellings can be found throughout the immediate neighbourhood. Commercial, Office and Institutional uses also exist within this neighbourhood area. Specific services and land uses are as follows:

North

- Hamilton Fire Station
- Pioneer Gas Station
- Food Basics
- Little Peoples Daycare
- Peter Pan Co-op Preschool

South

- Lincoln M. Alexander Pkwy

East

- Newlands Park
- Living Hope Christian Assembly
- Westmount Elementary School

- Westmount Secondary School
- Westmount Recreation Centre

West

- William McCulloch Park

2.3 Transportation

The subject property fronts onto Garth Street, which is a Municipal Road and designated a **‘Minor Arterial’** with a Right-of-Way (ROW) width of approximately 23 m. The Official Plan has identified Garth Street to be the subject of a road widening to 31.394 m. As such a Road Widening dedication will likely be requested by the City at time of lot severance.

The subject property is situated between four bus stops serving two transit routes. South of the property are Hamilton Street Railway (HSR) bus stops for bus routes 35 to St. Elizabeth Village and Frank A. Cooke Terminal (**Figure 6**).

South of the subject property is the Lincoln M. Alexander Parkway, which connects onto Highway 403, and the Red Hill Valley Parkway which eventually connects onto the Queen Elizabeth Way. While the subject property is surrounded by local roads, transportation via highways and bus routes are available.

Figure 6: HSR bus routes near subject property

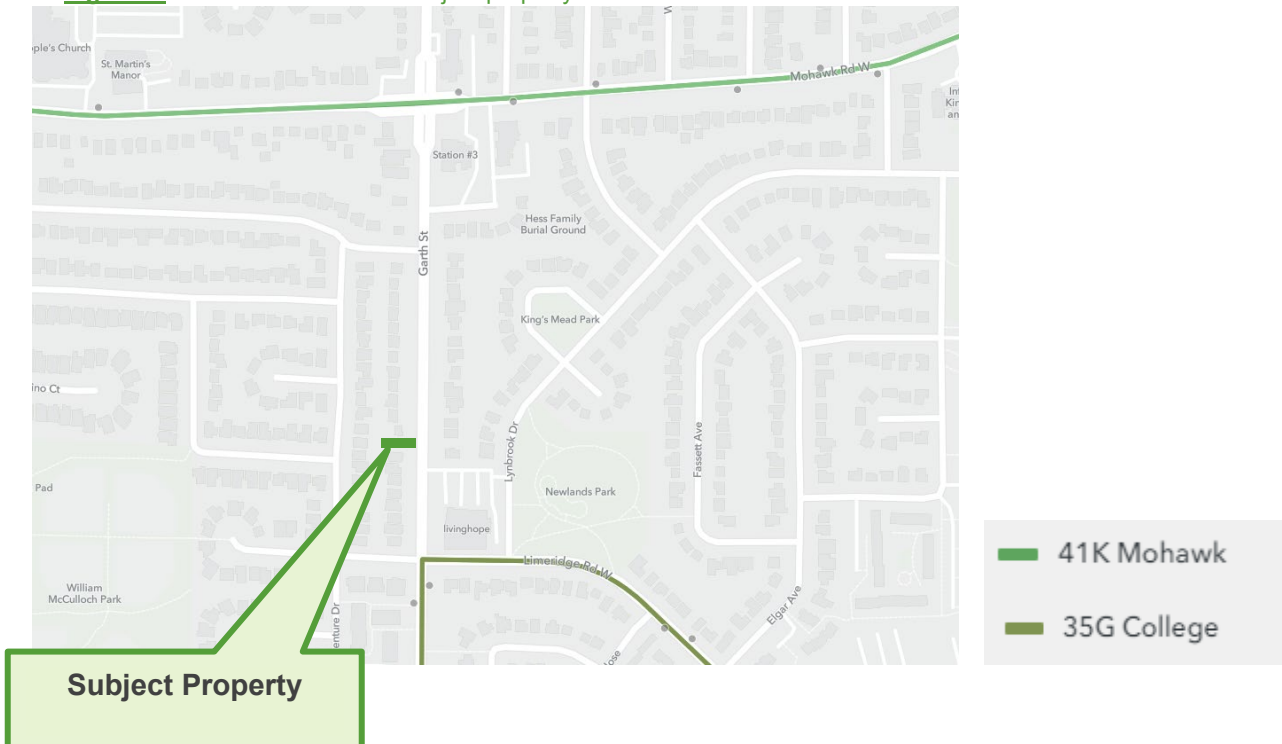

3.0 PROPOSED DEVELOPMENT & PLANNING APPLICATION

The subject property is currently being constructed as a ‘technical’ single-detached dwelling, but in the visual form of a semi-detached building. The property owner would like to convert the existing ‘single detached’ building into a pair of semi-detached dwellings (*being the same physical building, just reclassified*), with both dwellings being on separate properties to facilitate new ownership opportunities. In order to facilitate this, a consent to sever the land will be required and related minor variances, as well as a revised building permit (*for the post reclassification purposes*). Two minor variances are being requested in order to bring both the new and retained lots into conformity with the old, but in effect Zoning By-law.

The following table shows the proposed changes to the requirements on the subject property through a minor variance:

Table 1: Proposed Minor Variances

	Required	Proposed	
		Lot 1	Lot 2
Minimum Front Yard	6 m	6.2 m	6.0 m
Minimum Side Yard	1.2 m	1.35 m	1.2 m
Minimum Rear Yard	7.5 m	7.55 m	7.8 m
Minimum Lot Width	9 m	6.8 m	6.65 m
Minimum Lot Area	270 m ²	209.5 m²	205.5 m²
Maximum Height	2.5 storeys/11 m	<11.0 m	<11.0 m
Minimum Parking	1 space/unit	1 space/unit	1 space/unit
Minimum Parking Space Length	6 m	6.2 m	6.2 m
Minimum Parking Space Width	2.7 m	3 m	3 m

Figure 7: Concept severance sketch with proposed minor variances

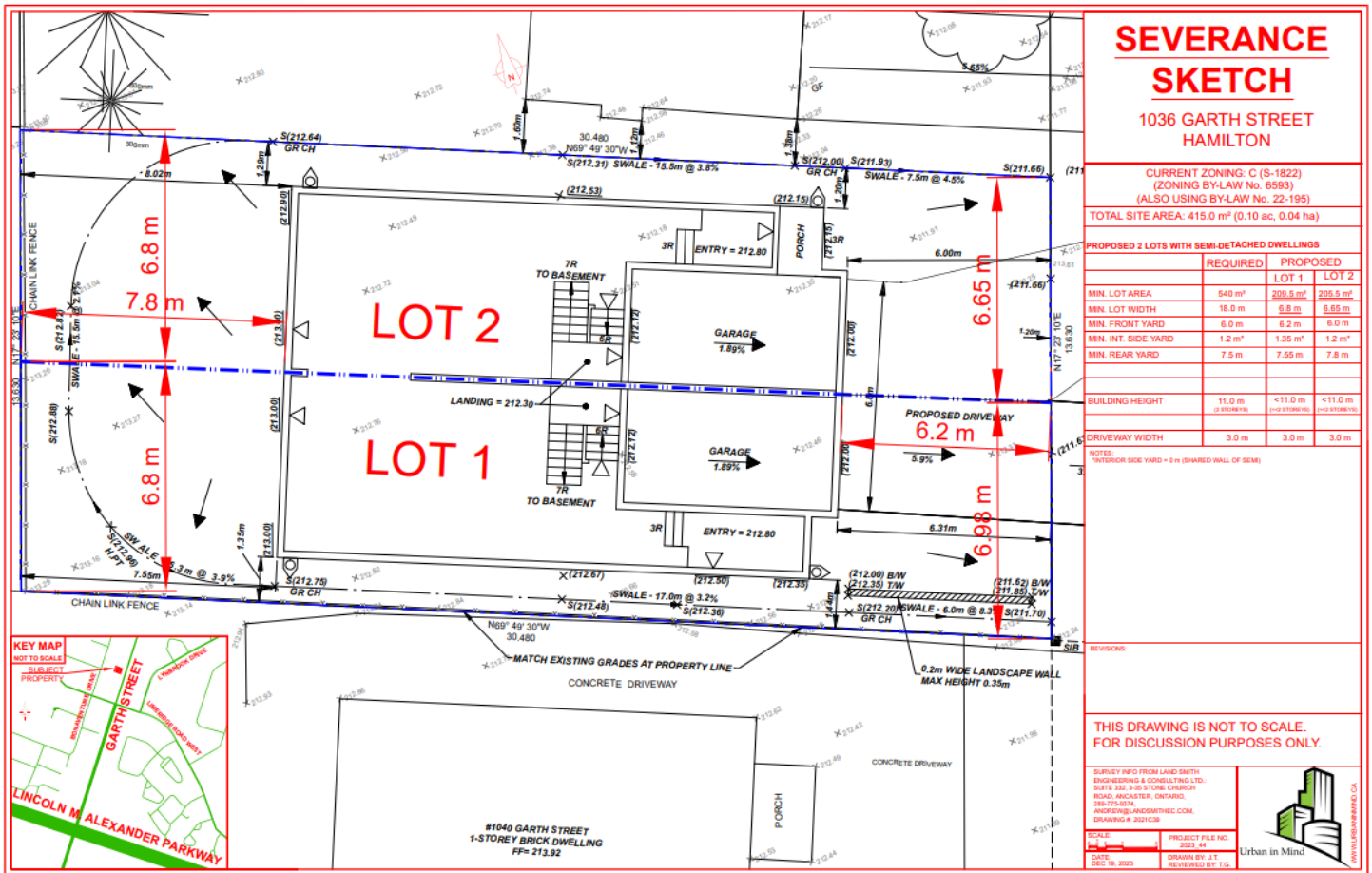

4.0 EXISTING PLANNING POLICY AND REGULATORY FRAMEWORK

4.1 Planning Act, R.S.O. 1990, c. P.13:

The Planning Act is the leading provincial legislation that sets out the rules for land use planning in Ontario. The Planning Act ensures that matters of provincial interest are met and guides planning policy to protect citizen rights and the natural environment.

Applicable provisions from the Planning Act have been included as follows:

“Provincial Interest

- 2 The Minister, the council of a municipality, a local board, a planning board and the Tribunal, in carrying out their responsibilities under the Act, shall have regard to, among other matters, matters of provincial interest such as,

- (a) *the protection of ecological systems, including natural areas, features, and functions;*
- (b) *the protection of agricultural resources of the Province*
- (c) *the conservation and management of natural resources and the mineral resource base;*
- (d) *the conservation of features of significant architectural, cultural, historical, archaeological or scientific interest;*
- (e) *the supply, efficient use and conservation of energy and water;*
- (f) *the adequate provision and efficient use of communication, transportation, sewage and water services and waste management systems;*
- (g) *the minimization of waste;*
- (h) *the orderly development of safe and healthy communities;*
- (h.1) *the accessibility for persons with disabilities to all facilities, services and matters to which this Act applies;*
- (i) *the adequate provision and distribution of educational, health, social, cultural, and recreational facilities;*
- (j) *the adequate provision of a full range of housing, including affordable housing;*
- (k) *the adequate provision of employment opportunities;*
- (l) *the protection of the financial and economic well-being of the Province and its municipalities;*
- (m) *the co-ordination of planning activities of public bodies;*
- (n) *the resolution of planning conflicts involving public and private interests;*
- (o) *the protection of public health and safety;*
- (p) *the appropriate location of growth and development;*
- (q) *the promotion of development that is designed to be sustainable, to support public transit and to be oriented to pedestrians;*
- (r) *the promotion of built form that,*
 - (i) *is well-designed,*

- (ii) encourages a sense of place, and
 - (iii) provides for public spaces that are of high quality, safe, accessible, attractive and vibrant;
- (s) the mitigation of greenhouse gas emissions and adaptation to a changing climate.

Powers of Committee

45 (1) *The committee of adjustment, upon the application of the owner of any land, building or structure affected by any by-law that is passed under section 34 or 38, or a predecessor of such sections, or any person authorized in writing by the owner, may, despite any other Act, authorize such minor variance from the provisions of the by-law, in respect of the land, building or structure or the use thereof, as in its opinion is desirable for the appropriate development or use of the land, building or structure, if in the opinion of the committee the general intent and purpose of the by-law and of the official plan, if any, are maintained.*

PART VI SUBDIVISION OF LAND

Plan of subdivision approvals

51(24) *In considering a draft plan of subdivision (i.e. and severance), regard shall be had, among other matters, to the health, safety, convenience, accessibility for persons with disabilities and welfare of the present and future inhabitants of the municipality and to,*

- (a) *the effect of development of the proposed subdivision on matters of provincial interest as referred to in section 2;*
- (b) *whether the proposed subdivision is premature or in the public interest;*
- (c) *whether the plan conforms to the official plan and adjacent plans of subdivision, if any;*
- (d) *the suitability of the land for the purposes for which it is to be subdivided;*
- (d.1) *if any affordable housing units are being proposed, the suitability of the proposed units for affordable housing;*
- (e) *the number, width, location and proposed grades and elevations of highways, and the adequacy of them, and the highways linking the highways in the proposed subdivision with the established highway system in the vicinity and the adequacy of them;*
- (f) *the dimensions and shapes of the proposed lots;*
- (g) *the restrictions or proposed restrictions, if any, on the land proposed to be subdivided or the buildings and structures proposed to be erected on it and the restrictions, if any, on adjoining land;*

- (h) *conservation of natural resources and flood control;*
- (i) *the adequacy of utilities and municipal services;*
- (j) *the adequacy of school sites;*
- (k) *the area of land, if any, within the proposed subdivision that, exclusive of highways, is to be conveyed or dedicated for public purposes;*
- (l) *the extent to which the plan's design optimizes the available supply, means of supplying, efficient use and conservation of energy; and*
- (m) *the interrelationship between the design of the proposed plan of subdivision and site plan control matters relating to any development on the land, if the land is also located within a site plan control area designated under subsection 41 (2) of this Act or subsection 114 (2) of the City of Toronto Act, 2006. 1994, c. 23, s. 30; 2001, c. 32, s. 31 (2); 2006, c. 23, s. 22 (3, 4); 2016, c. 25, Sched. 4, s. 8 (2)."*

4.2 Provincial Policy Statement (2020):

The Provincial Policy Statement (PPS) for the Province of Ontario was recently updated in May 2020. It provides Provincial Policy direction on matters of Provincial interest related to land development under the Planning Act. The Goal of the PPS is to enhance the quality of life for all people living, working and/or playing in Ontario.

Simply put, when municipal governments contemplate land use policies (e.g. Official Plan, Secondary Plan, Zoning By-law, Site Plan, etc.) or consider planning applications under these policies, the PPS must be considered.

The applicable PPS policies have been incorporated into the City's Official Plan.

Applicable policies from the Provincial Policy Statement have been included as follows:

"Part V: Policies

1.0 Building Strong Healthy Communities

1.1 Managing and Directing Land Use to Achieve Efficient and Resilient Development and Land Use Patterns

1.1.1 Healthy, liveable and safe communities are sustained by:

- a) promoting efficient development and land use patterns which sustain the financial well-being of the Province and municipalities over the long term;**

- c) avoiding development and land use patterns which may cause environmental or public health and safety concerns;
- e) promoting the integration of land use planning, growth management, transit-supportive development, intensification and infrastructure planning to achieve cost-effective development patterns, optimization of transit investments, and standards to minimize land consumption and servicing costs;

1.1.3 Settlement Areas

1.1.3.2 Land use patterns within settlement areas shall be based on densities and a mix of land uses which:

- a) efficiently use land and resources;
- b) are appropriate for, and efficiently use, the infrastructure and public service facilities which are planned or available, and avoid the need for their unjustified and/or uneconomical expansion;
- f) are transit-supportive, where transit is planned, exists or may be developed

Land use patterns within settlement areas shall also be based on a range of uses and opportunities for intensification and redevelopment in accordance with the criteria in policy 1.1.3.3, where this can be accommodated.

1.1.3.3 Planning authorities shall identify appropriate locations and promote opportunities for transit-supportive development, accommodating a significant supply and range of housing options through intensification and redevelopment where this can be accommodated taking into account existing building stock or areas... and the availability of suitable existing or planned infrastructure and public service facilities required to accommodate projected needs.

1.4 Housing

1.4.1 To provide for an appropriate range and mix of housing options and densities required to meet projected requirements of current and future residents of the regional market area, planning authorities shall:

- a) maintain at all times the ability to accommodate residential growth for a minimum of 15 years through residential intensification and redevelopment and, if necessary, lands which are designated and available for residential development; and
- b) maintain at all times where new development is to occur, land with servicing capacity sufficient to provide at least a three-year supply of residential units available through lands suitably zoned to facilitate residential intensification and redevelopment, and land in draft approved and registered plans.

Upper-tier and single-tier municipalities may choose to maintain land with servicing capacity sufficient to provide at least a five-year supply of residential units available through lands suitably zoned to facilitate residential intensification and redevelopment, and land in draft approved and registered plans.

1.4.2 Where planning is conducted by an upper-tier municipality:

- a) the land and unit supply maintained by the lower-tier municipality identified in policy 1.4.1 shall be based on and reflect the allocation of population and units by the upper-tier municipality; and
- b) the allocation of population and units by the upper-tier municipality shall be based on and reflect provincial plans where these exist.

1.4.3 Planning authorities shall provide for an appropriate range and mix of housing options and densities to meet projected market-based and affordable housing needs of current and future residents of the regional market area by:

- b) permitting and facilitating:
 - 1. all housing options required to meet the social, health, economic and well-being requirements of current and future residents, including special needs requirements and needs arising from demographic changes and employment opportunities; and
 - 2. all types of residential intensification, including additional residential units, and redevelopment in accordance with policy 1.1.3.3;
- c) directing the development of new housing towards locations where appropriate levels of infrastructure and public service facilities are or will be available to support current and projected needs;
- d) promoting densities for new housing which efficiently use land, resources, infrastructure and public service facilities, and support the use of active transportation and transit in areas where it exists or is to be developed;
- f) establishing development standards for residential intensification, redevelopment and new residential development which minimize the cost of housing and facilitate compact form, while maintaining appropriate levels of public health and safety.

4.3 Growth Plan for the Greater Golden Horseshoe (2019):

The Growth Plan for the Greater Golden Horseshoe (Growth Plan) is a Provincial Policy that aims to control growth and development within the Greater Golden Horseshoe Area in a way that supports economic prosperity, protects the environment and improves the quality of life for all residents. The

Growth Plan also encourages intensification by directing a significant portion of new growth to the built-up areas of communities, thus protecting agricultural areas from encroaching development and incompatible land uses.

The Growth Plan (updated 2019) further enhances the provincial direction to locate new growth within settlement areas, support urban intensification, create complete communities, maximize utility efficiency, and encourage transit usage.

The subject property is located within the ‘**Built-Up Area**’ of the Growth Plan (**Appendix ‘B’**).

Applicable excerpts from the related Growth Plan policy are as follows:

“1.2.1 Guiding Principles

The successful realization of this vision for the GGH centres on effective collaboration amongst the Province, other levels of government, First Nations and Métis communities, residents, private and non-profit sectors across all industries, and other stakeholders. The policies of this Plan regarding how land is developed, resources are managed and protected, and public dollars are invested are based on the following principles:

- Support the achievement of complete communities that are designed to support healthy and active living and meet people’s needs for daily living throughout an entire lifetime.
- Prioritize intensification and higher densities in strategic growth areas to make efficient use of land and infrastructure and support transit viability.
- Provide for different approaches to manage growth that recognize the diversity of communities in the GGH.

2 Where and How to Grow

2.2 Policies for Where and How to Grow

2.2.1 Managing Growth

2) Forecasted growth to the horizon of this Plan will be allocated based on the following:

- a) the vast majority of growth will be directed to settlement areas that:
 - i. have a delineated built boundary;
 - ii. have existing or planned municipal water and wastewater systems; and
 - iii. can support the achievement of complete communities;
- c) within settlement areas, growth will be focused in:
 - i. delineated built-up areas;
 - ii. strategic growth areas;
 - iii. locations with existing or planned transit, with a priority on higher order transit where it exists or is planned; and
 - iv. areas with existing or planned public service facilities;

- 4) Applying the policies of this Plan will support the achievement of complete communities that:
 - a) feature a diverse mix of land uses, including residential and employment uses, and convenient access to local stores, services, and public service facilities;
 - b) improve social equity and overall quality of life, including human health, for people of all ages, abilities, and incomes;
 - c) provide a diverse range and mix of housing options, including additional residential units and affordable housing, to accommodate people at all stages of life, and to accommodate the needs of all household sizes and incomes;

2.2.2 Delineated Built-up Areas

1. By the time the next municipal comprehensive review is approved and in effect, and for each year thereafter, the applicable minimum intensification target is as follows:
 - a) A minimum of 50 per cent of all residential development occurring annually within each of the Cities of Barrie, Brantford, Guelph, Hamilton, Orillia and Peterborough and the Regions of Durham, Halton, Niagara, Peel, Waterloo and York will be within the delineated built-up area; and
2. Until the next municipal comprehensive review is approved and in effect, the annual minimum intensification target contained in the applicable upper- or single-tier official plan that is approved and in effect as of July 1, 2017 will continue to apply.
3. All municipalities will develop a strategy to achieve the minimum intensification target and intensification throughout delineated built-up areas, which will:
 - b) identify strategic growth areas to support achievement of the intensification target and recognize them as a key focus for development;
 - c) identify the appropriate type and scale of development in strategic growth areas and transition of built form to adjacent areas;
 - d) encourage intensification generally throughout the delineated builtup area;
 - e) ensure lands are zoned and development is designed in a manner that supports the achievement of complete communities;
 - f) prioritize planning and investment in infrastructure and public service facilities that will support intensification; and
 - g) be implemented through official plan policies and designations, updated zoning and other supporting documents.
4. Councils of upper- and single-tier municipalities may request an alternative to the target established in policy 2.2.2.1 where it is demonstrated that this target cannot be achieved and that the alternative target will be appropriate given the size, location and capacity of the delineated built-up area.

5. The Minister may permit an alternative to the target established in policy 2.2.2.1. If council does not make a request or the Minister does not permit an alternative target, the target established in policy 2.2.2.1 will apply.

4.4 Greenbelt Plan:

The subject property is not located within the ‘Greenbelt Plan Area’ (Appendix ‘C’). As such, the policies of the Greenbelt Plan do not apply to the subject property.

4.5 Hamilton Conservation Authority (HCA):

The subject property is located within the jurisdiction of the Hamilton Conservation Authority, but is not within any regulated areas (Appendix ‘D’). The HCA Online Regulated Areas mapping tool displays a watercourse within 100 m of the subject property, but it has been confirmed by Conservation staff that the watercourse is actually enclosed in pipe, and as such, HCA approval will not be required, nor will a Conservation Development Permit as the subject property is not located within the regulated areas nor is it within close proximity to any.

4.6 Urban Hamilton Official Plan (November 2022 Consolidation):

The Urban Hamilton Official Plan (UHOP) is an overriding policy document that guides the City’s actions to achieve its goals pertaining to the communities, land use, and physical development over the next 30 years. The current Official Plan is the first that integrates the former communities of Ancaster, Dundas, Flamborough, Glanbrook, Stoney Creek, and the Former City of Hamilton, all of which has amalgamated into the present-day City of Hamilton. The UHOP was adopted by Council in 2009 and the most recent office consolidation is from November 2022.

The following designations apply to the subject property:

- The subject property is designated as a ‘Neighbourhood Area’ that is within the ‘Urban Area’ (Appendix ‘E’).
- The subject property is within the ‘Area of Archaeological Potential’ (Appendix ‘F’).

Applicable excerpts are as follows:

B.2.0 Defining Our Communities

2.1 Urban Boundary

- 2.1.1 The urban boundary defines the area where all urban development occurs. The land within the urban boundary includes both the area within the built-up area and greenfield area. (OPA 167, MMAH Mod. 8)

2.4 Residential Intensification

Residential intensification is a key component of Hamilton's growth strategy and is essential to meet our growth and employment targets. Intensification ensures land, urban services and the transportation network are used more efficiently and sufficient population is maintained to support existing community facilities. Successfully accommodating more residents within the existing built-up area reduces the need for development of greenfield lands and urban boundary expansions.

Intensification contributes to creating and maintaining vibrant neighbourhoods, nodes and corridors and can provide a wider range of housing types to meet the housing needs of Hamilton's current and future population. This Plan supports the intensification of the existing built-up area of the City, with a focus on intensification of planned Urban Nodes and Urban Corridors described in Chapter E – Urban Systems and Designations.

While growth through residential intensification brings many benefits to communities and the City as a whole, it must be recognized that it also brings change in varying degrees across the City. In node and corridor areas targeted to receive intensification, greater changes in built form can be expected to occur.

Residential intensification is a key component in successfully developing and transforming targeted areas of the City. Intensification creates livable, vibrant, compact communities; facilitates and enhance the node and corridor structure of the City, and makes efficient use of the City's public transit network and other infrastructure. For intensification to make a positive contribution to the City, careful consideration must be given to design and compatibility with existing uses, neighbourhood character, and cultural and natural heritage. Intensification must represent good planning and not cause unacceptable impacts.

2.4.1 General Residential Intensification Policies

2.4.1.1 Residential intensification shall be encouraged throughout the entire built-up area, shown on Appendix G in accordance with the policies of Chapter E – Urban Systems and Designations and Chapter F – Implementation. (OPA 167)

2.4.1.3 The residential intensification target shall be established through a future Amendment to this Plan as part of this municipal comprehensive review. The housing units specified in Policy A.2.3.2 shall generally be distributed through the built-up area as follows:

- c)** 30% of the residential intensification target is anticipated to occur within the Neighbourhoods as illustrated on Schedule E – Urban Structure. The City will review and update its Zoning By-law to facilitate the planned housing units to be developed within the Neighbourhoods through intensification. (OPA 167, Mod. 12)

2.4.1.4 Residential intensification developments within the built-up area shall be evaluated based on the following criteria:

- a) a balanced evaluation of the criteria in b) through l), as follows;
- b) the relationship of the proposed development to existing neighbourhood character so that it builds upon desirable established patterns and built form;
- c) the contribution of the proposed development to maintaining and achieving a range of dwelling types and tenures;
- d) the compatible integration of the proposed development with the surrounding area in terms of use, scale, form and character.
- f) existing and planned water, wastewater and stormwater capacity;
- j) the availability and location of existing and proposed public community facilities/services;

2.4.2 Residential Intensification in the Neighbourhoods Designation

2.4.2.1 Residential intensification within the built-up area and on lands designated Neighbourhoods identified on Schedule E-1 - Urban Land Use Designations shall comply with Section E.3.0 – Neighbourhoods Designation. (OPA 167)

2.4.2.2 When considering an application for a residential intensification development within the Neighbourhoods designation, the following matters shall be evaluated:

- a) the matters listed in Policy B.2.4.1.4;
- b) compatibility with adjacent land uses including matters such as shadowing, overlook, noise, lighting, traffic, and other nuisance effects;
- c) the relationship of the proposed building(s) with the height, massing, and scale of nearby residential buildings;
- d) the consideration of transitions in height and density to adjacent residential buildings;
- e) the relationship of the proposed lot(s) with the lot pattern and configuration within the neighbourhood;
- g) the ability to respect and maintain or enhance the streetscape patterns including block lengths, setbacks and building separations;
- h) the ability to complement the existing functions of the neighbourhood;

B.3.2 Housing Policies

Housing is fundamental to the economic, social and physical well-being of Hamilton's residents and communities. Housing is a basic human need and is the central place from which people build their lives, nurture their families and themselves, and engage in their communities. Housing needs to change and evolve as social, demographic, and economic conditions change. The long term sustainability of communities is based on building a diverse, flexible housing stock today to meet changing needs at both household and community levels. To ensure that housing is available for all residents with a wide variety of needs, there must be a sufficient supply of housing with a range of housing types, forms, tenures, densities, affordability levels, and housing with support services.

3.2.1 Urban Housing Goals

The following goals shall apply in the urban area:

- 3.2.1.1** Provide for a range of housing types, forms, and densities to meet the social, health and well-being requirements of all current and future residents.
- 3.2.1.2** Provide housing within complete communities.

3.2.2 Housing Targets

The housing targets in Tables B.3.2.1 – Housing Targets – Ownership and B.3.2.2 – Housing Targets – Rental are based on future population growth forecasts to the year 2051 and future housing need. Targets for affordable rental housing are divided into housing affordable for low and moderate income households. The targets for the provision of housing which is affordable to low and moderate income households is informed by, and shall align with the City's Housing and Homelessness Action Plan. Meeting the housing targets for housing affordable for low and moderate income households will require sustainable and predictable funding from senior levels of government. (OPA 167)

- 3.2.2.1** Projected housing targets based on population and household forecasts in Tables A.1 and A.2 are provided in Table B.3.2.1 – Housing Targets – Ownership, and Table B.3.2.2 - Housing Targets – Rental. (OPA 167)

Table B.3.2.1 – Housing Targets – Ownership (OPA 167)

Target Type	Target # of Units Annually	% of Total Annual Target by Tenure	Product to Achieve Target	Methods to Achieve Target
New Ownership Housing (market rate)	1071	40%	New and resale homes	Housing market
New Ownership Housing Affordable to Low & Moderate Income Households (includes housing with supports)	1606	60%	New and resale homes	Housing market, low-down payment options, first-time buyer programs, support services
Total New Ownership Housing	2677	100%		

3.2.4 General Policies for Urban Housing

3.2.4.1 The City shall plan for the full continuum of housing to ensure that an appropriate range and mix of housing forms, types, and densities to meet market-based and affordable housing needs of current and future residents through residential intensification, new development, and redevelopment is available. The full continuum of housing includes built form, tenure and affordability including single detached dwellings, semi-detached dwellings, duplexes, townhouses of various types (street, block, stacked), apartments and other forms of multiple dwellings, and lodging houses, built at a range of densities and ownership and rental tenures. (OPA 167)

E.1.0 Goals

The following goals shall apply to the urban systems and land use designations of this plan.

- d) Develop complete communities where people can live, work, learn, and play.
- h) Recognize that Hamilton’s neighbourhoods will evolve over time to accommodate projected household growth, and changing demographics, and respond to the changing needs of complete communities. (OPA 167)

2.7 Neighbourhoods

Neighbourhoods are where the majority of Hamiltonians live, learn, shop, socialize, and play. A key component of Hamilton’s urban structure, the Neighbourhoods element is an all encompassing element representing the concept of complete community at the structural level. Neighbourhoods occupy the greatest proportion of the City, containing a mix of low, medium, and high-rise residential areas; various types of roads, parks, open spaces, and commercial areas; and institutions such schools and places of worship.

The Neighbourhoods are bordered and bisected, in a number of locations by Urban Corridors. These corridors are a separate structural element from the Neighbourhoods, but in many locations function as an integral part of the surrounding Neighbourhood, often serving as the central focal point.

Hamilton's neighbourhoods are, by and large, regarded as stable. However, that does not mean these areas are static. These neighbourhoods will see some physical change over time. Neighbourhoods will evolve as older residents move out, younger residents and families move in, homes are renovated or rebuilt, infill development occurs, commercial areas are invigorated, or underutilized commercial areas redeveloped. Residential intensification within Neighbourhoods is part of the evolution of a neighbourhood and can happen at a range of scales and densities provided the intensification is compatible with and respects the built form and character of the surrounding neighbourhood.

Function

- 2.7.2** Neighbourhoods shall primarily consist of residential uses and complementary facilities and services intended to serve the residents. These facilities and services may include parks, schools, trails, recreation centres, places of worship, small retail stores, offices, restaurants, and personal and government services.
- 2.7.3** The Neighbourhood element of the urban structure shall be implemented through land use designations shown on Schedule E-1 – Urban Land Use Designations.
- 2.7.4** The Neighbourhoods element of the urban structure shall permit and provide the opportunity for a full range of housing forms, types and tenure, including affordable housing and housing with supports.

Scale

- 2.7.7** Neighbourhoods shall generally be regarded as physically stable areas with each neighbourhood having a unique scale and character. Changes compatible with the existing character or function of the neighbourhood shall be permitted. Applications for development and residential intensification within Neighbourhoods shall be reviewed in consideration of the local context and shall be permitted in accordance with Sections B.2.4 – Residential Intensification, E.3.0 – Neighbourhoods Designation, E.4.0 – Commercial and Mixed-Use Designations, and, E.6.0 – Institutional Designation.

E.3.0 Neighbourhoods Designation

Hamilton's neighbourhoods are diverse, ranging from old, historic areas of the City, to newly developed subdivisions. Each neighbourhood has its own unique character. Together, neighbourhoods create the rich mosaic of the City.

Neighbourhoods provide the context for daily life for citizens. Neighbourhoods are “living areas” - places where we live, learn, play and socialize on a daily basis. The designation “Neighbourhoods” recognizes that our neighbourhoods are made up of more than just homes, but include a variety of land uses. The mix of uses is important in a neighbourhood. Also important are the relationships between these uses, the locations of the uses, how they function together, how they are designed, and how they are accessed by local residents.

The intent of the Neighbourhoods designation is to describe neighbourhood functions, identify appropriate scales of development and design requirements for various land uses, and allow for the continued evolution of neighbourhoods.

3.1 Policy Goals

The following goals apply to the Neighbourhoods land use designation:

- 3.1.3** Plan and designate lands for a range of housing types and densities, taking into account affordable housing needs.
- 3.1.4** Promote and support design which enhances and respects the character of existing neighbourhoods while at the same time allowing their ongoing evolution.
- 3.1.5** Promote and support residential intensification of appropriate scale and in appropriate locations throughout the neighbourhoods.

3.2 Neighbourhoods Designation – General Policies

Function

- 3.2.1** Areas designated Neighbourhoods shall function as complete communities, including the full range of residential dwelling types and densities as well as supporting uses intended to serve the local residents.
- 3.2.3** The following uses shall be permitted on lands designated Neighbourhoods on Schedule E-1 – Urban Land Use Designations:

- a) residential dwellings, including second dwelling units and housing with supports;

Scale and Design

- 3.2.4** The existing character of established Neighbourhoods designated areas shall be maintained. Residential intensification within these areas shall enhance and be compatible with the scale and character of the existing residential neighbourhood in accordance with Section B.2.4 – Residential Intensification and other applicable policies of this Plan.

3.2.13 The City supports residential intensification on lands within the Neighbourhoods designation in accordance with Section B.2.4 – Residential Intensification Policies, F.1.14 – Division of Land, and other applicable policies.

3.2.15 The City shall encourage the adaptive reuse of the existing building stock for appropriate land uses.

3.3 Residential Uses – General Policies

Three categories of residential land use are described in this section but are not designated on Schedule E-1 – Urban Land Use Designations. These residential categories provide general location, scale, and design directions for the purposes of secondary planning and zoning. These categories may also be applied in the redevelopment of larger sites.

3.3.1 Lower density residential uses and building forms shall generally be located in the interiors of neighbourhood areas with higher density dwelling forms and supporting uses located on the periphery of neighbourhoods on or in close proximity to major or minor arterial roads.

3.3.2 Development or redevelopment adjacent to areas of lower density shall ensure the height, massing, and arrangement of buildings and structures are compatible with existing and future uses in the surrounding area.

3.4 Low Density Residential Function

3.4.1 The preferred location for low density residential uses is within the interior of neighbourhoods.

3.4.2 Low density residential areas are characterized by lower profile, grade-oriented built forms that generally have direct access to each unit at grade.

3.4.3 Uses permitted in low density residential areas:

- a) shall include single-detached, semi-detached, duplex, triplex, fourplex, and street townhouse dwellings; and, (OPA 167)
- b) may include multiple dwellings containing a maximum of 6 units for lots in proximity to collector roads or arterial roads (OPA 167)

F.1.14

1.14.3 Lot Creation – Urban Area Neighbourhoods Designation

1.14.3.1 Consents for new lot creation, for both the severed and retained lands, for residential uses in the Neighbourhoods designation shown on Map E-1 – Urban Land Use Designation, shall be permitted provided the following conditions are met:

- a) The lots comply with the policies of this Plan, including secondary plans, where one exists;
- b) The lots are in conformity with the Zoning By-law or a minor variance is approved;
- c) The lots reflect the general scale and character of the established development pattern in the surrounding area by taking into consideration lot frontages and areas, building height, coverage, mass, setbacks, privacy and overview;
- d) The lots are fully serviced by municipal water and wastewater systems; and,
- e) The lots have frontage on a public road.

4.5 Former City of Hamilton Zoning By-law 6593 (Consolidated 2022):

The City of Hamilton is an amalgamation of six (6) former cities, each of which had their own Zoning By-laws. For most of the properties in the former municipalities, the policies that regulate institutional, industrial, parks and open space uses are provided by By-law No. 05-200. However, residential uses remain to be governed by the former community's by-laws on certain properties. The subject property is located within the Former City of Hamilton, and By-law No. 6593 applies to the subject property and uses.

- The subject property is zoned as '**C/S-1822' Urban Protected Residential** with site-specific provisions resulting from By-law No. 22-195 (**Appendix 'G'**). These site-specific provisions require semi-detached dwellings on 'C' designated lands to adhere to specific policies in the R-4 Districts (Small Lot Single Family Dwelling).

Applicable excerpts are as follows:

Section Nine "C" Districts

Urban Protected Residential, etc.

Residential Uses

- (i) A single family dwelling, together with the accommodation of lodgers to the number of not more than three; (81-27)
- (ii) Semi Detached dwellings – as per Site Specific Provision C/S-1822

Miscellaneous Or Incidental Uses

- (vii) A private garage; (92-170)
- (viii) Parking spaces to such a number as is reasonably necessary for a permitted use to which the same is appurtenant, provided that the same are hard-surfaced and abut

upon a hard-surfaced driveway giving ready access to a street or alley, and that same are used only as appurtenant to such permitted use, (6902/52) And provided further that the foregoing shall not be construed so as to permit the expansion for such purpose of a non-conforming use; (6902/52)

Height Requirements

- 2) In a "C" District, no building shall exceed two and a half storeys, and no structure shall exceed 11.0 metres (36.09 feet), in height. (9141/60) (79-288) (80-049)

Section Eighteen A

Parking and Loading Requirements

- 7) Every required parking space, other than a parallel parking space, shall have dimensions not less than 2.7 metres wide and 6.0 metres long.
- 7b) Where a dwelling is constructed with an attached garage, then the finished level of the garage floor shall be a minimum of 0.3 metres above grade. (97-112)

Figure 8: Former City of Hamilton Zoning By-law 6593 Table 1 Minimum Parking Requirements

**TABLE 1 - MINIMUM REQUIRED PARKING FOR,
RESIDENTIAL, INSTITUTIONAL, PUBLIC AND COMMERCIAL USES**

TABLE 1

<u>Class of Use (Column 1)</u>	<u>Minimum Number of Required Parking Spaces (Column 2)</u>
1. <u>Residential Uses</u>	
(a) Single family dwelling;	(a) 2 parking spaces for each Class A dwelling unit, for the first 8 habitable rooms in the dwelling unit plus 0.5 parking space for each additional habitable room; (97-112)
(b) Two family dwelling;	(b) 1 space per Class A dwelling unit;

Site-Specific Zoning By-law No. 22-195 (*Special Provision C/S-1822*):

Figure 9: Permitted uses in Low Density Residential Zones, as Amended by By-law 22-195 (C/S-1822)

Use	"B-1" District	"B-2" District	"C" District	"R-4" District	"D" District	"R-2" District
Semi-Detached Dwelling	✓	✓	✓		✓	✓
Two Family Dwelling	✓	✓	✓	✓		
Street Townhouse Dwelling	✓	✓	✓	✓	✓	✓

That notwithstanding Section 9. (3) and (4), in the "C" (Urban Protected Residential, etc.) District, the following provisions shall apply to the uses permitted in Section 3 b) to this By-law:

A Semi-Detached Dwelling shall be subject to the provisions as provided in subsection 9A. **(3) (b) and (c)**

Former City of Hamilton Zoning By-law 6593 cont'd.

Section Nine A "R-4" Districts
Small Lot Single Family Dwelling

(3) Every Semi-Detached Dwelling shall comply with the following,

- b) Area Requirements:** 1. There shall be provided and maintained upon the same lot or tract of land within the "R-4" District for every building or structure,
 - i.** a front yard having a depth of not less than 6.0 metres;
 - ii.** a side yard along each side lot line having a width of not less than 1.2 metres;
 - iii.** a rear yard having a depth of not less than 7.5 metres.
- c) Intensity of Use Requirements:** 1. Every lot or tract of land shall have,
 - i.** a lot width of not less than 18.0 metres;
 - ii.** a lot area of not less than 540.0 square metres.

5.0 SEVERANCE JUSTIFICATION

5.1 Planning Act

The proposed severance will result in the creation of (1) one new residential lot and (1) retained lot for the purpose of converting the existing 'single detached dwelling' into a pair of semi-detached dwellings, each on their own separate lots. The subject property is located in an area that is well-serviced and suitable to support new and existing development. The proposed lot sizes and configurations are appropriate for the area, as they will respect and enforce existing neighbourhood character, as outlined in the City's Official Plan. The proposed severance will allow for a more efficient use of the subject lands, as they will provide new home ownership opportunities. Overall, the proposed severance of the lots is appropriate and desirable as it will maintain their current uses and functions, which are compatible with the surrounding neighbourhood. As a result, the proposed severance will not impact or disrupt surrounding properties or prevailing neighbourhood character.

As such, the proposed development conforms to the provisions and intent of the Planning Act and should be considered 'GOOD PLANNING'.

5.2 Provincial Policy Statement

The original severance that created the subject property was granted for the purpose of creating an infill development on what would have otherwise been underutilized land. Similarly, the current proposal aims to intensify the land and create a new opportunity for home ownership in a manner that integrates another housing type and size to contribute to the achievement of a more diverse range of housing types and ownerships. The proposed development will remain appropriate in land use patterns and it will be cohesive to the existing neighbourhood. The scale of development being proposed is respectful towards the existing neighbourhood while contributing to the housing market as the population is expected to continue to grow in the Greater Golden Horseshoe.

As such, the proposed development conforms with the policies of the Provincial Policy Statement and should be considered 'GOOD PLANNING'.

5.3 Growth Plan for the Greater Golden Horseshoe

The proposed severance supports the achievement of complete communities as it builds upon an established neighbourhood with existing infrastructure and services. As a result, it minimizes land consumption and increases land use in a manner that is appropriate in scale to

the surrounding neighbourhood. The use of existing infrastructure will prevent any uneconomical expansion or development of services as a result of the proposed severance. While the immediate area surrounding the subject property mainly consist of single-detached dwellings, a pair of semi-detached dwellings will be able to maintain the existing character, just as the semi-detached dwellings on nearby Bonaventure Drive have. Permitting the technical severance of the subject property would be aligned with the Growth Plan's goal to contribute to the growth of the community in a manner that is in support of a diverse range and mix of housing and ownership options. The desired semi-detached dwelling would be an ideal approach to add diversity to the housing options while maintaining the existing character of the neighbourhood as to not disrupt the cohesion of the current built form.

As such, the proposed development conforms with the policies of the Growth Plan and should be considered 'GOOD PLANNING'.

5.4 Urban Hamilton Official Plan

The proposed severance is aligned with the City's Official Plan as it conforms to the designated land use within the Neighbourhood area. Permitting the severance of the subject property will enable the property owner to convert the existing 'technical' single-detached dwelling into a pair of semi-detached dwellings, creating an additional dwelling unit in the neighbourhood. The proposed semi-detached dwellings will be facilitated in a manner that is respectful and considerate of the existing neighbourhood character, which mainly consists of single-detached homes and a select few of semi-detached dwellings. The proposed severance will contribute to the City's goals in increasing housing choice by promoting a more diverse range of housing types in the City. It has been acknowledged in the Official Plan that spaces are expected to evolve overtime, and the proposed development will be a respectful example of established neighbourhoods adapting to changes in demand associated with population and employment growth.

As such, the proposed severance conforms with the policies of the Urban Hamilton Official Plan, and in particular, the evaluation criteria for residential intensification and land severance. Thus, the proposed severance should be considered 'GOOD PLANNING'.

5.5 Former City of Hamilton Zoning By-law No. 6593

The proposed semi-detached building development generally complies with the Zoning By-law, with the exception of lot frontage and lot area, that will require minor variances. The type of use will remain the same as the current zoning, as By-law No. 22-195 permits semi-detached dwellings on "C" District lands. The proposed height and massing will not exceed what is permitted in Zoning By-law 6593. However, the proposed development will result in an

insufficient lot width and area size that will not be aligned with the requirements set out in By-law No. 22-195. As such, a minor variance for these elements is being proposed.

5.6 Four Tests of a Minor Variance

Section 45(1) of the Planning Act states that the Committee of Adjustment may authorize variances from the provisions of the Zoning By-Law provided that the 'Four Tests' are satisfied. This section provides an analysis that evaluates the proposal's required variances within the context of the four tests as follows:

1. Do the requested variances maintain the general intent and purpose of the Official Plan?
2. Do the requested variances maintain the general intent and purpose of the Zoning By-Law?
3. Are the requested variances desirable and appropriate for the lands?
4. Are the requested variances minor in nature?

The requested variances to amend Section 9A of Zoning By-law 6593 maintains the general intent and purpose of the Official Plan and will have no impact on the goals or purposes of the Official Plan. It also maintains the general intent and purpose of the Zoning By-law as it will not affect the compliance of the rest of the policies set out in the By-law. The application seeks approval to continue as the site conditions currently exist, and is deemed to be desirable and appropriate as it will not interfere with other policies. Instead, it will contribute to the housing and ownership goals set out in the Official Plan. The Official Plan recognizes and enables change and transformation as the City continues to evolve overtime, and the variances will allow the subject property to engage in such changes in a manner that maintains the respect to the land use designation and the surrounding neighbourhood, while contributing to residential intensification and the creation of more home ownership opportunities.

6.0 CONCLUSION

It is the Author's professional planning opinion as a Registered Professional Planner, that given the respective Provincial, Regional, Conservation, and City policies, as well as surrounding character conditions, the proposed land severance and minor variances should be considered **'Good Planning,'** is in the public interest, is consistent with the Provincial Policy Statement and the Growth Plan for the Greater Golden Horseshoe, conforms with the Urban Hamilton Official Plan, as well as the intent of the Former City of Hamilton Zoning By-Law, and maintains and compliments the character of the existing neighbourhood.

As such, the above justification supports the proposed amendment being approved.

I hereby certify that this Planning Justification Report was prepared and/or reviewed by Registered Professional Planner (RPP), within the meaning of the *Ontario Professional Planners Institute Act*, 1994.



Terrance Glover, RPP, CPT, MCIP
Principal

Urban in Mind, Professional Urban Planning, Land Development & CPTED Consultants



Appendix A

Approved & Issued Building Permit for 1036 Garth Street



Search Results

Building New Construction

Show 10 entries

Application #	Description	Address	Status
23 105630 00	To construct a 2-storey, 307.7m ² single family dwelling. Model: Custom - 4 Bedroom To install a 32mm water service line To install a 25mm water meter To install a 100 mm Diameter Sanitary Building Sewer. To install a 100 mm Diameter Storm Building Sewer.	1036 GARTH ST HAMILTON	Issued

Showing page 1 of 1

Previous 1 Next

Appendix B

Growth Plan for the Greater Golden Horseshoe – Schedule 4

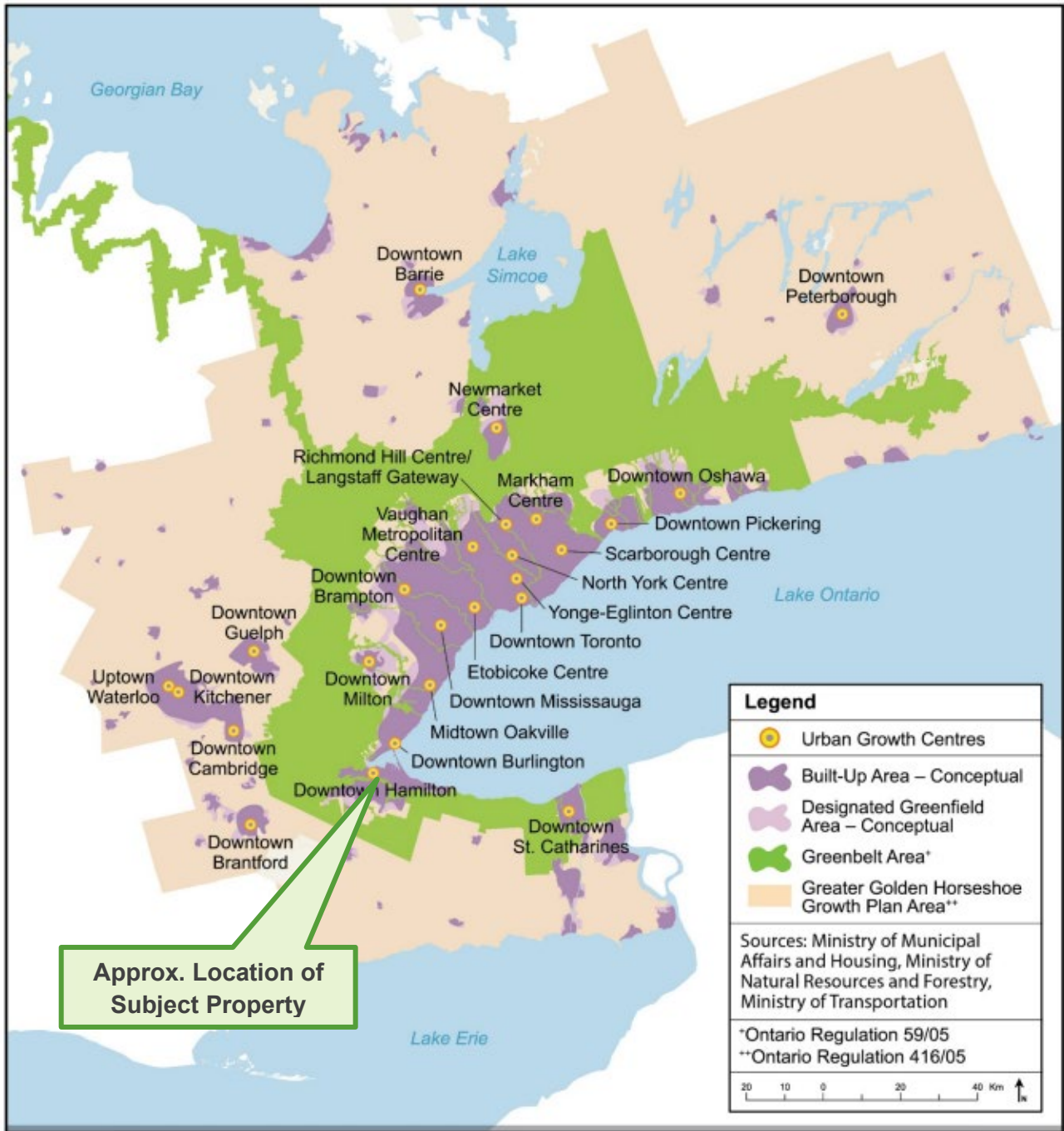

Appendix C

Greenbelt Plan Area

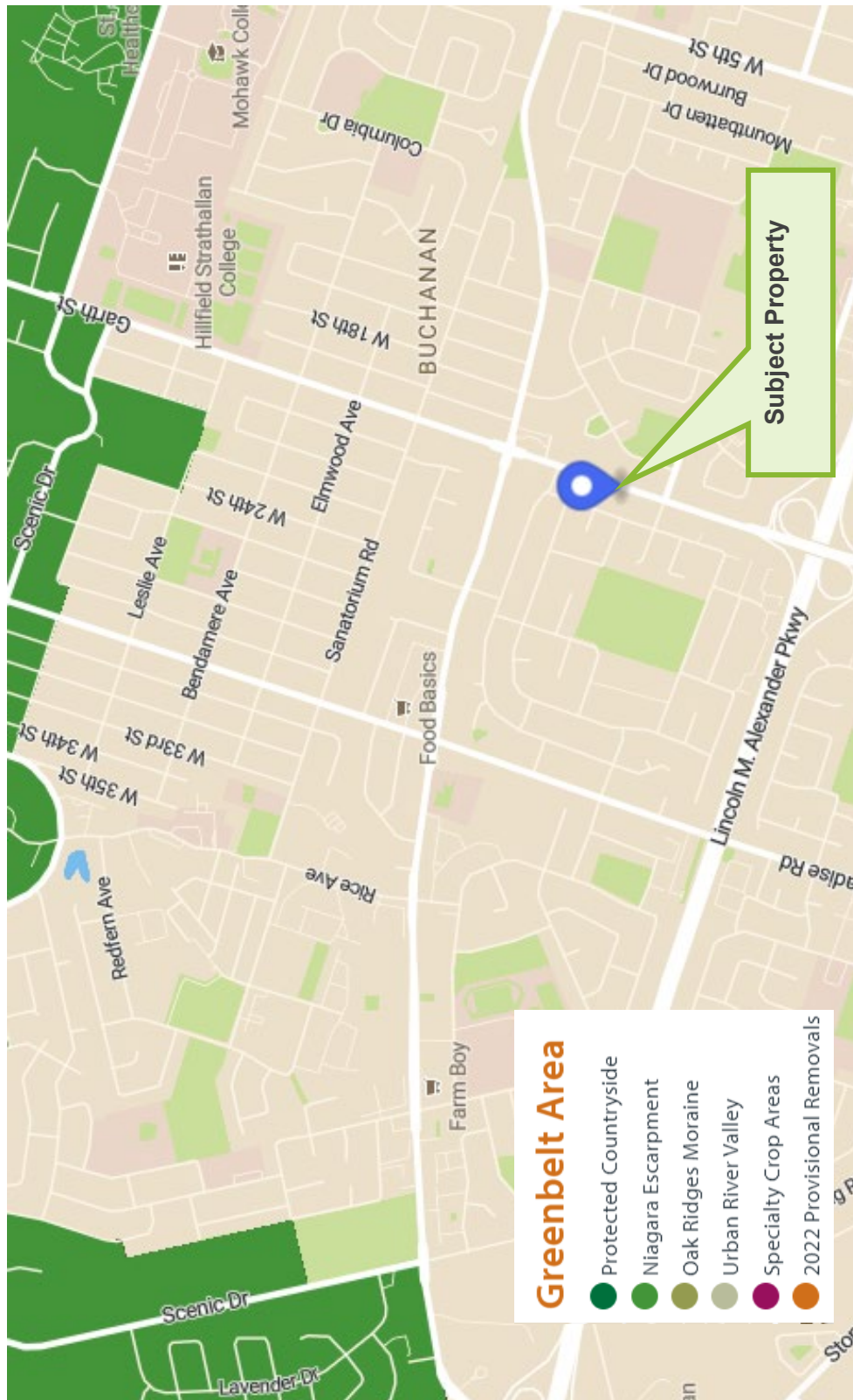

Appendix D
Hamilton Conservation Authority – Regulated Areas

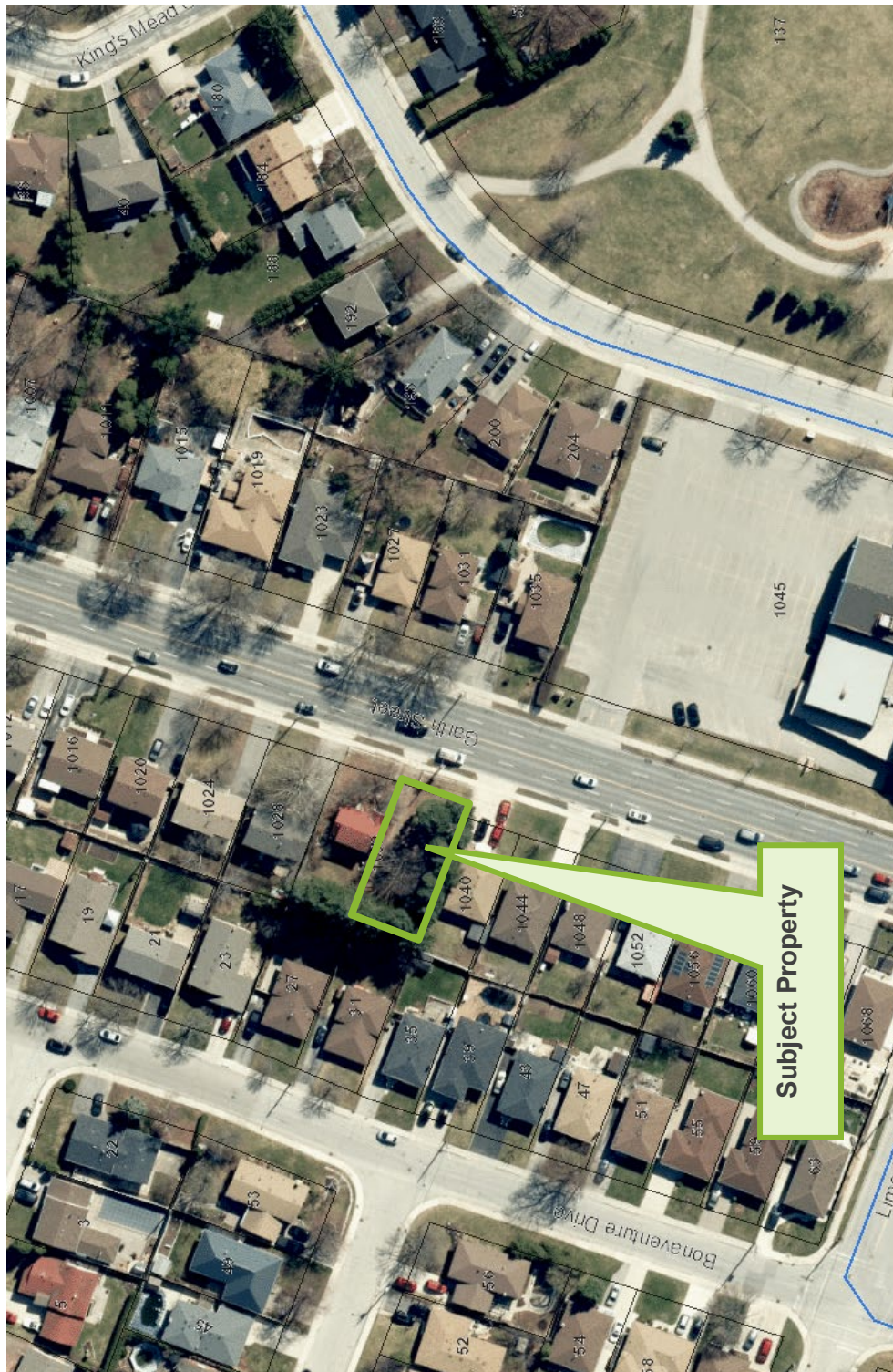

Appendix E

Urban Hamilton Official Plan – Schedule E-1 – Urban Land Use Designations

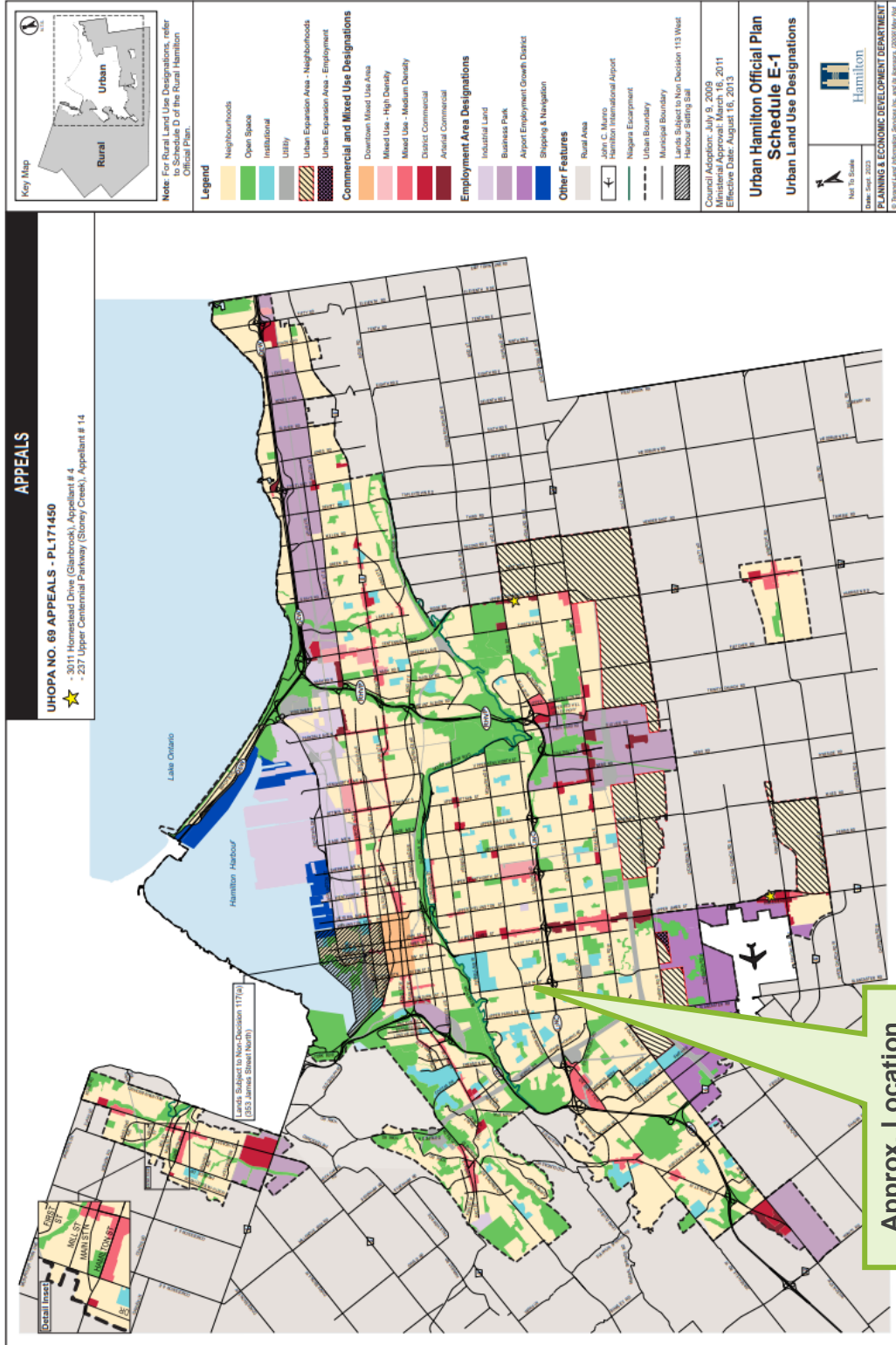

Approx. Location of Subject Property

Appendix F

Urban Hamilton Official Plan – Appendix F-4 – Archaeological Potential

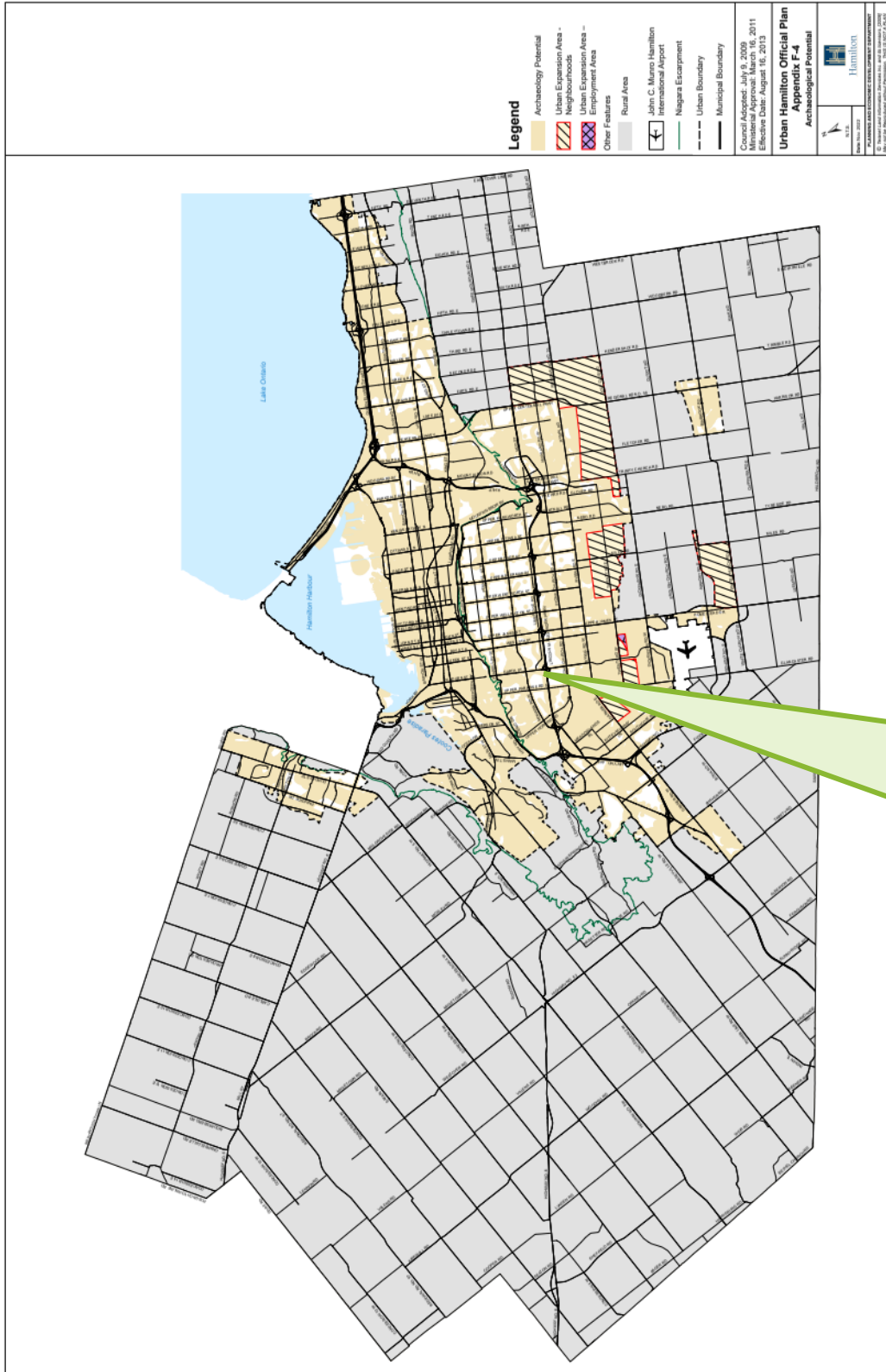

Approx. Location of Subject Property

Appendix G

City of Hamilton Zoning By-law Designations

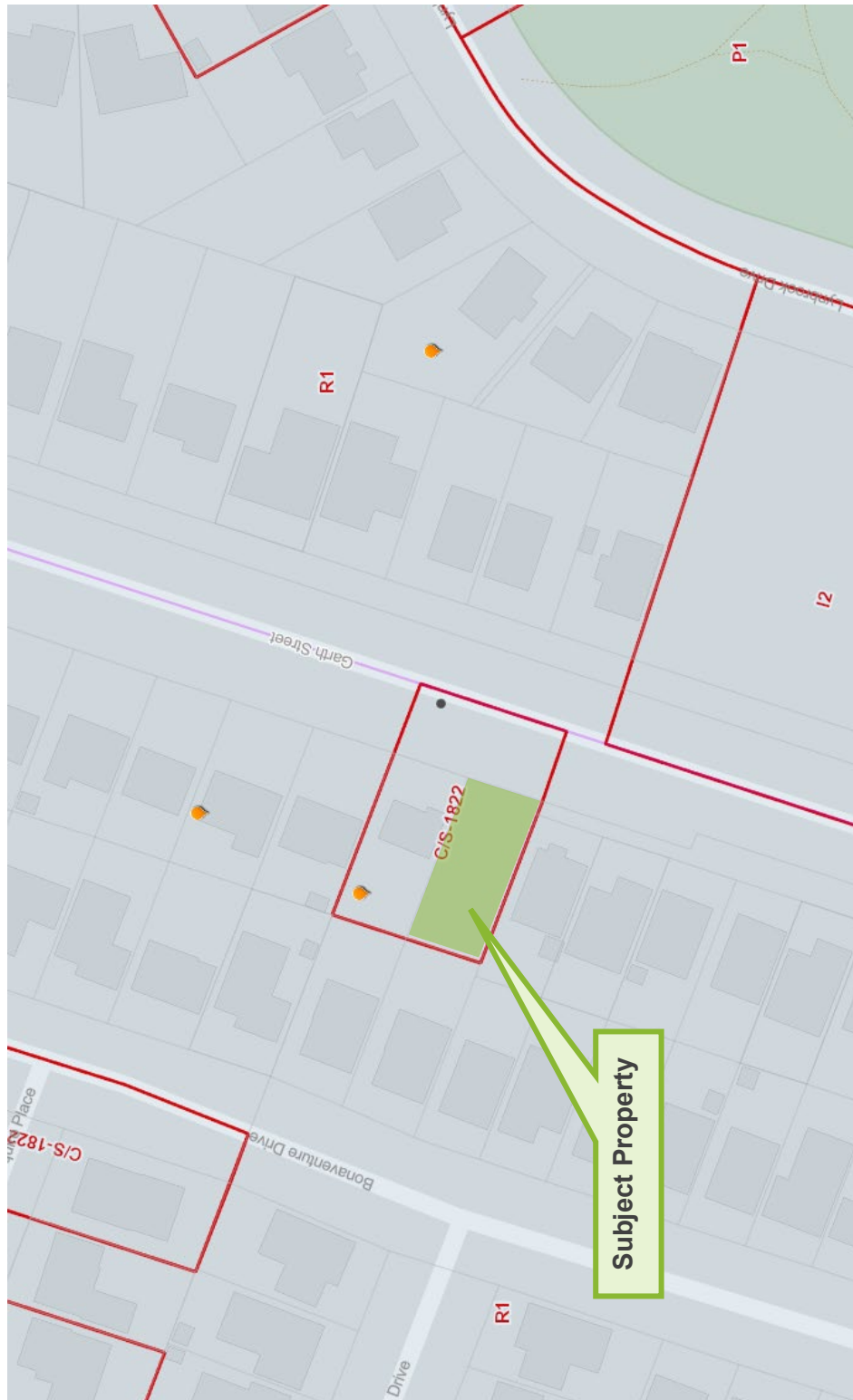



Hamilton

Committee of Adjustment

City Hall, 5th Floor,

71 Main St. W.,

Hamilton, ON L8P4Y5

Phone: (905) 546-2424 ext. 4221

Email: cofa@hamilton.ca

APPLICATION FOR A MINOR VARIANCE/PERMISSION UNDER SECTION 45 OF THE PLANNING ACT

1. APPLICANT INFORMATION

Table with 2 columns: Category (Registered Owners(s), Applicant(s), Agent or Solicitor) and Name.

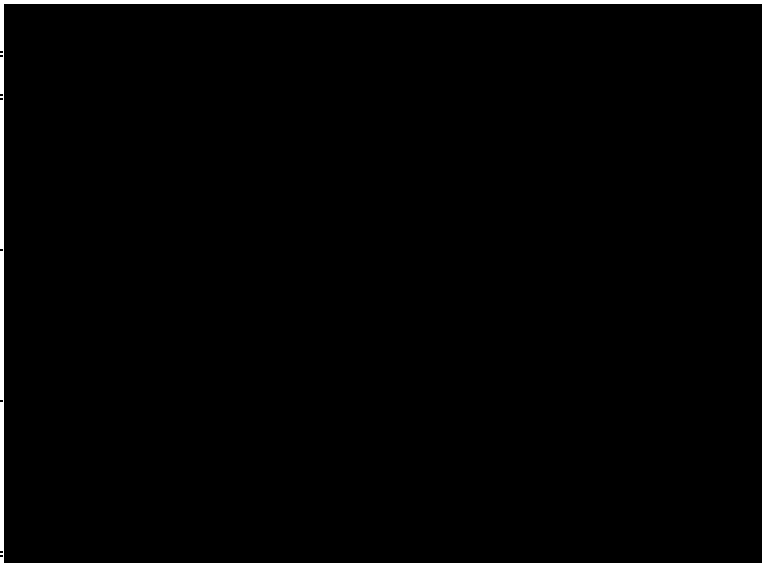

1.2 All correspondence should be sent to [checkbox] Purchaser [checkbox] Owner [checkbox checked] Applicant [checkbox] Agent/Solicitor

1.3 Sign should be sent to [checkbox] Purchaser [checkbox checked] Owner [checkbox] Applicant [checkbox] AgentSolicitor

1.4 Request for digital copy of sign [checkbox checked] Yes* [checkbox] No

If YES, provide email address where sign is to be sent [Redacted]

1.5 All correspondence may be sent by email [checkbox checked] Yes* [checkbox] No

If Yes, a valid email must be included for the registered owner(s) AND the Applicant/Agent (if applicable). Only one email address submitted will result in the voiding of this service. This request does not guarantee all correspondence will sent by email.

2. LOCATION OF SUBJECT LAND

2.1 Complete the applicable sections:

Municipal Address	1036 Garth Street		
Assessment Roll Number	081021066220000		
Former Municipality	Township of Barton		
Lot	19	Concession	6
Registered Plan Number		Lot(s)	
Reference Plan Number (s)		Part(s)	1

2.2 Are there any easements or restrictive covenants affecting the subject land?

Yes No

If YES, describe the easement or covenant and its effect:

3. PURPOSE OF THE APPLICATION

Additional sheets can be submitted if there is not sufficient room to answer the following questions. Additional sheets must be clearly labelled

All dimensions in the application form are to be provided in metric units (millimetres, metres, hectares, etc.)

3.1 Nature and extent of relief applied for:

New lots created through severance to divide a pair of semi-detached dwellings.

Second Dwelling Unit

Reconstruction of Existing Dwelling

3.2 Why it is not possible to comply with the provisions of the By-law?

The severance will result in a lot width and area that are deficient to the current City Zoning By-law.

3.3 Is this an application 45(2) of the Planning Act.

Yes

No

If yes, please provide an explanation:

4. DESCRIPTION OF SUBJECT LAND AND SERVICING INFORMATION

4.1 Dimensions of Subject Lands:

Lot Frontage	Lot Depth	Lot Area	Width of Street
13.63 m	30.48 m	415 sq.m.	23 m

4.2 Location of all buildings and structures on or proposed for the subject lands:
(Specify distance from side, rear and front lot lines)

Existing:

Type of Structure	Front Yard Setback	Rear Yard Setback	Side Yard Setbacks	Date of Construction
Single detached dwelling	6 m	7.55 m	1.20 m	

Proposed:

Type of Structure	Front Yard Setback	Rear Yard Setback	Side Yard Setbacks	Date of Construction
Semi-detaching dwelling (1)	6.0 m	7.8 m	1.20 m	
Semi-detached dwelling (2)	6.2 m	7.55 m	1.35 m	

4.3. Particulars of all buildings and structures on or proposed for the subject lands (attach additional sheets if necessary):

Existing:

Type of Structure	Ground Floor Area	Gross Floor Area	Number of Storeys	Height
Single detached dwelling	307.69 sq.m.		2	8.9 m

Proposed:

Type of Structure	Ground Floor Area	Gross Floor Area	Number of Storeys	Height
(1) Semi-detached	153.84 sq.m.		2	8.9 m
(2) Semi-detached	153.84 sq.m.		2	8.9 m

- 4.4 Type of water supply: (check appropriate box)
 publicly owned and operated piped water system
 privately owned and operated individual well

- lake or other water body
 other means (specify)

- 4.5 Type of storm drainage: (check appropriate boxes)
 publicly owned and operated storm sewers
 swales

- ditches
 other means (specify)

4.6 Type of sewage disposal proposed: (check appropriate box)

publicly owned and operated sanitary sewage

system privately owned and operated individual

septic system other means (specify) _____

4.7 Type of access: (check appropriate box)

provincial highway

right of way

municipal road, seasonally maintained

other public road

municipal road, maintained all year _____

4.8 Proposed use(s) of the subject property (single detached dwelling duplex, retail, factory etc.):
Semi-detached dwellings

4.9 Existing uses of abutting properties (single detached dwelling duplex, retail, factory etc.):
Single detached dwellings

7 HISTORY OF THE SUBJECT LAND

7.1 Date of acquisition of subject lands:

January 17, 2012

7.2 Previous use(s) of the subject property: (single detached dwelling duplex, retail, factory etc)

Infill single detached dwelling

7.3 Existing use(s) of the subject property: (single detached dwelling duplex, retail, factory etc)

Single detached dwelling (built in the form of 2 possible units)

7.4 Length of time the existing uses of the subject property have continued:

Built 2023

7.5 What is the existing official plan designation of the subject land?

Rural Hamilton Official Plan designation (if applicable): _____

Rural Settlement Area: _____

Urban Hamilton Official Plan designation (if applicable) Neighbourhood

Please provide an explanation of how the application conforms with the Official Plan.

See Planning Justification Report.

7.6 What is the existing zoning of the subject land? C/S-1822

7.8 Has the owner previously applied for relief in respect of the subject property?

(Zoning By-law Amendment or Minor Variance)

Yes

No

If yes, please provide the file number: _____

7.9 Is the subject property the subject of a current application for consent under Section 53 of the *Planning Act*?

Yes

No

If yes, please provide the file number: Previous consent NO.HM/B-21:08

7.10 If a site-specific Zoning By-law Amendment has been received for the subject property, has the two-year anniversary of the by-law being passed expired?

Yes

No

7.11 If the answer is no, the decision of Council, or Director of Planning and Chief Planner that the application for Minor Variance is allowed must be included. Failure to do so may result in an application not being “received” for processing.

8 ADDITIONAL INFORMATION

8.1 Number of Dwelling Units Existing: _____

8.2 Number of Dwelling Units Proposed: _____

8.3 Additional Information (please include separate sheet if needed):

The owner is proposing the conversion of the single detached dwelling into a semi-detached where each dwelling will be on separate properties.

11 COMPLETE APPLICATION REQUIREMENTS

11.1 All Applications

- Application Fee
- Site Sketch
- Complete Application form
- Signatures Sheet

11.4 Other Information Deemed Necessary

- Cover Letter/Planning Justification Report
 - Authorization from Council or Director of Planning and Chief Planner to submit application for Minor Variance
 - Minimum Distance Separation Formulae (data sheet available upon request)
 - Hydrogeological Assessment
 - Septic Assessment
 - Archeological Assessment
 - Noise Study
 - Parking Study
-
-