

CULTURAL HERITAGE ASSESSMENT REPORT



**340 Dundas Street East, Waterdown
(Eager House)
City of Hamilton**

Prepared by Lisa Oversby, Heritage Project Intern
and Alissa Golden, Heritage Project Specialist

Heritage Resource Management Section
Tourism and Culture Division
Planning and Economic Development Department
City of Hamilton

January 10, 2020 (DRAFT FOR COMMENT)

CULTURAL HERITAGE ASSESSMENT REPORT: A READER'S GUIDE

This cultural heritage assessment report is prepared as part of a standard process that assists in determining the cultural heritage value of properties and their prospective merit for protection, including designation and/or a heritage conservation easement agreement, under the *Ontario Heritage Act*.

This report is divided into eight sections:

Section 1 comprises an introduction.

Section 2, *Property Location*, briefly describes the physical location, legal description and dimensions of the property.

Section 3, *Physiographic Context*, contains a description of the physiographic region in which the subject property is located.

Section 4, *Settlement Context*, contains a description of the broad historical development of the settlement in which the subject property is located as well as the development of the subject property itself. A range of secondary sources such as local histories and a variety of historical and topographical maps are used to determine settlement history.

Section 5, *Property Description*, describes the subject property's key heritage characteristics that provide the base information to be used in Section 6.

Section 6, *Cultural Heritage Evaluation*, comprises a detailed evaluation of the subject property using the three sets of evaluation criteria: archaeology; built heritage; and, cultural heritage landscapes.

Section 7, *Cultural Heritage Value: Conclusions and Recommendations*, comprises a brief summary of the Cultural Heritage Evaluation and provides a list of those criteria that have been satisfied in determining cultural heritage value, as well as determining compliance with Ontario Regulation 9/06. It also contains a recommendation as to whether or not the subject property should be protected under the *Ontario Heritage Act* through designation and/or a heritage conservation easement agreement, including a Statement of Cultural Heritage Value or Interest and Description of Heritage Attributes.

Section 8, *Bibliography*, comprises a list of sources used in the compilation of the report.

Table of Contents

1. Introduction	7
1.1 Waterdown Village Built Heritage Inventory Project.....	7
1.2 Potential Designation and Next Steps.....	7
1.3 Property Location.....	7
2. Physiographic Context	8
3. Settlement Context	9
3.1 Indigenous Settlement.....	9
3.2 Euro Canadian Settlement.....	10
3.3 Contemporary Context.....	15
4. Property Description	17
4.1 Evolution of the Buildings and Landscape.....	17
4.2 Building Description.....	19
5. Cultural Heritage Evaluation	21
5.1 Archaeology.....	21
5.1.1 <i>Archaeological Potential</i>	21
5.2 Built Heritage.....	21
5.2.1 <i>Historical Associations</i>	22
5.2.2 <i>Architecture and Design</i>	23
5.2.3 <i>Integrity</i>	24
5.2.4 <i>Environmental Context</i>	25
5.2.5 <i>Social Value</i>	26
5.3 Cultural Heritage Landscapes.....	26
6. Cultural Heritage Value: Conclusions and Recommendations	28
6.1 Conclusions.....	28
6.2 Compliance with Ontario Regulation 9/06: Criteria for Determining Cultural Heritage Value or Interest.....	29
6.2.1 <i>Design / Physical Value</i>	29
6.2.2 <i>Historical / Associative Value</i>	30
6.2.3 <i>Contextual Value</i>	30

6.3 Recommendation 31

Bibliography 34

Appendix A: Location Map 37

Appendix B: Photographs 38

Appendix C: Historical Images 42

Appendix D: Plans and Mapping..... 50

Appendix E: Ownership History..... 53

Appendix F: Primary Documents..... 54

DRAFT FOR COMMENT

Table of Figures

<i>Figure 1: The physiographic regions of Southern Ontario from Chapman and Putnam's The Physiography of Southern Ontario, 1984, Page 113 (Approximate location of Waterdown identified by red circle)</i>	8
<i>Figure 2: Dish With One Spoon Wampum Belt Reproduction (utoronto.ca).....</i>	9
<i>Figure 3: Geneva concessions as illustrated on a map of the treaties with the Indigenous from the Mississaugas of the Credit First Nation webpage.....</i>	11
<i>Figure 4: Eager Store located on the southeast corner of Dundas and Mill Street, looking southeast to see the Eager House in the background, circa 1904; Source: Flamborough Archives, BW 71, Will Reid Collection.....</i>	13
<i>Figure 5: Photograph of James E. Eager; Source: The Mills of Waterdown, page 106 (photograph provided by his daughter Helen Eager).....</i>	14
<i>Figure 6: Looking south down Reynold Street from Dundas Street East, showing the Eager House on the right (June 2018)</i>	15
<i>Figure 7: Vinegar Hill, looking west down Dundas Street towards the bridge with the white fence of the Eager House on the left, circa 1907; Source; Flamborough Archives, BW 2810</i>	16
<i>Figure 8: Vinegar Hill, looking west down Dundas Street to the bridge (June 2018).....</i>	16
<i>Figure 9: 340 Dundas Street East, highlighted in grey, City of Hamilton GISnet, 2019.</i>	17
<i>Figure 10: Insurance Plan of the Village of Waterdown, ON, May 1939, Excerpt of Sheet 1 (Existing property boundary of 340 Dundas Street East highlighted in red)</i>	18
<i>Figure 11: Eager House including front porch and windows, 1982; Source: Flamborough Archives, BW 269.....</i>	20
<i>Figure 12: Eager House including front porch and windows, 2018</i>	20
<i>Figure 13: Map of subject property and surrounding area, City of Hamilton GISNet.....</i>	37
<i>Figure 14: Aerial view of subject property and immediate vicinity, City of Hamilton GISNet (2017)</i>	37

1. Introduction

This cultural heritage assessment report examines the cultural heritage value or interest of the property located at 340 Dundas Street East in Waterdown. The property is comprised of a two-storey stone dwelling constructed in the late-nineteenth century, which has remained largely unmodified. The subject property was listed on the City's Municipal Heritage Register on November 21, 2019 (Planning Committee Report 19-014).

1.1 Waterdown Village Built Heritage Inventory Project

This assessment is conducted as part of the Waterdown Village Built Heritage Inventory Project, the latest phase in the City of Hamilton's ongoing Built Heritage Inventory Process. Previous phases of this process include the Downtown Built Heritage Inventory Project, completed in 2014 (PED14191), and the Durand Neighbourhood Built Heritage Inventory, completed in 2017 (PED17092).

The primary goal of this inventory project is to evaluate each property within the Waterdown Village study area to determine its heritage value or interest. This evaluation will guide future cultural heritage decision making and policy creation.

1.2 Potential Designation and Next Steps

The subject property has been identified as a property of potentially significant cultural heritage value. As a result, extensive research has been conducted to determine the cultural heritage value of the property, which is outlined in this document, and could result in a recommendation for designation under Part IV of the *Ontario Heritage Act*.

1.3 Property Location

The 0.34-acre subject property, comprised of a two-storey stone dwelling clad with stucco, is located east of the Village of Waterdown's historic core, in an area known as Vinegar Hill, on the southwest corner of Dundas and Reynold Streets, just over the Dundas bridge to the east of Mill Street.

2. Physiographic Context

The subject property is located within the physiographic region known as the Niagara Escarpment,¹ at a point where the escarpment meets the Norfolk Sand Plain and the Horseshoe Moraine.² The Niagara Escarpment has greatly influenced land use in Southern Ontario, its rocky outcroppings limiting agricultural opportunities in certain areas and concentrating the construction of roads, railways, and urban settlements into the escarpment's few breaks and valleys.³ For settlers, the escarpment served as an important source of building material such as cut stone, lime, and shale, and its numerous streams and waterfalls permitted the development of early industries such as Waterdown's various historic mills.⁴

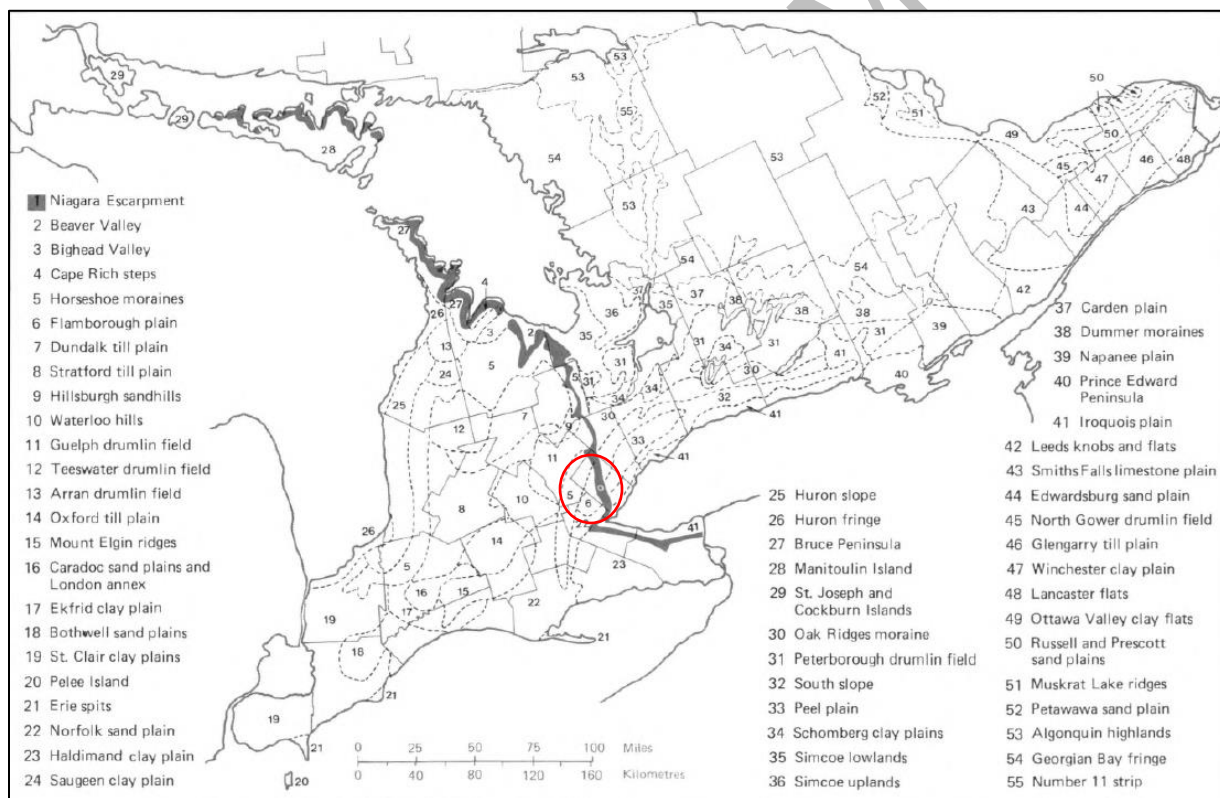

Figure 1: The physiographic regions of Southern Ontario from Chapman and Putnam's *The Physiography of Southern Ontario, 1984, Page 113* (Approximate location of Waterdown identified by red circle)

¹ L.J. Chapman and D.F. Putnam, *The Physiography of Southern Ontario* (Toronto: Ontario Ministry of Natural Resources, 1984), 114-122.

² L.J. Chapman and D.F. Putnam, Figure 19: *The 55 physiographic regions of Southern Ontario*, in *The Physiography of Southern Ontario*, by L.J. Chapman and D.F. Putnam (Toronto: Ontario Ministry of Natural Resources, 1984), 113.

³ Chapman and Putnam, *Physiology of Southern Ontario*, 119.

⁴ Chapman and Putnam, *Physiology of Southern Ontario*, 119.

3. Settlement Context

3.1 Indigenous Settlement

The area encompassing the former Township of East Flamborough and the Village of Waterdown has attracted human settlement since long before their formal establishment. The Grindstone Creek runs south through Waterdown towards Hamilton Harbour and was central to an extensive trail network traveled by the Indigenous Chonnonton People, commonly known as the Neutrals, which abounded with food and resources such as sugar maple and salmon.⁵ These trails, the origins of contemporary roads such as Snake Road and Old Waterdown Road, led the Neutrals from the base of the escarpment to their settlements north and west of present day Waterdown.⁶

The Neutrals, dubbed as such by explorer Samuel Champlain in 1615 for their lack of participation in wars between the neighbouring Huron and Iroquois people, were a powerful chiefdom which traded extensively throughout present day Ontario and New York.⁷ The Neutral's population was decimated by a 1638 smallpox outbreak and subsequent conflict and defeat by the Seneca and Mohawk during the Beaver Wars of the mid-17th century.⁸ The Mississaugas, an Anishinaabe nation who inhabited the lands east of the Neutrals, established settlement in the area following the Beaver Wars and were the predominant Indigenous group at the time of arrival by European settlers.⁹ In the late 17th century, the Anishinaabe and Haudenosaunee nations established peace with the "Dish with One Spoon" Wampum promising that the two nations would share the bounty of the land (the dish) together (using one spoon).¹⁰



Figure 2: Dish With One Spoon Wampum Belt Reproduction (utoronto.ca)

⁵ Donald R. Woods and Diane E. Woods, *The Mills of Waterdown: The Growth of an Ontario Village – 1790 to 1915* (Waterdown, ON: The Waterdown – East Flamborough Heritage Society, 2010), 2-3; Sylvia Wray, Robert Wray, Patricia Green and Maurice Green, *...and they came to East Flamborough: A Celebration of East Flamborough Township's pre-Confederation Heritage* (Waterdown, ON: The Waterdown-East Flamborough Heritage Society, 2015), 18-19.

⁶ Waterdown-East Flamborough Centennial Committee, *1867-1967: Waterdown and East Flamborough* (Waterdown, ON: Waterdown-East Flamborough Centennial Committee, 1967), 41.

⁷ Woods and Woods, *The Mills of Waterdown*, 2-5.

⁸ Woods and Woods, *The Mills of Waterdown*, 2-5.; Patricia Green, Maurice Green, Sylvia Wray and Robert Wray, *from West Flamborough's storied past* (Waterdown, ON: The Waterdown – East Flamborough Heritage Society, 2003), 2.

⁹ William C. Noble, "The Neutral Confederacy," *Canadian Encyclopedia*, last modified October 16, 2018. <https://www.thecanadianencyclopedia.ca/en/article/neutral.>; Green, Green, Wray and Wray, *from West Flamborough's Storied Past*, 2.

¹⁰ Nathan Tidridge, *The Extraordinary History of Flamborough: East Flamborough, West Flamborough & Waterdown* (Waterdown, ON: The Waterdown-East Flamborough Heritage Society, 2016), 11.

3.2 Euro Canadian Settlement

Beginning in the 1780s, Euro-Canadian settlement in the area superseded that of Indigenous populations.¹¹ The American War for Independence (1775-1783) greatly influenced settlement in the Flamborough and Waterdown area. Following the establishment of the United States of America in 1783, approximately 30,000 British Loyalists were displaced and sought refuge in Britain's remaining North American colonies.¹² In response to this demand for settlement lands, fifteen land surrender treaties were negotiated between the Crown and the Anishinaabe peoples living in present day Southern Ontario between 1783 and 1812.¹³ These treaties gave the colonial government authority to survey and eventually distribute lands to Loyalists and other European settlers.¹⁴ In 1788, to further facilitate the surveying of new settlement lands, the western extent of Quebec's District of Montreal was subdivided into four districts: Lunenburg, Mecklenburg, Nassau and Hesse. The area which would become East Flamborough, and subsequently the Village of Waterdown, was situated within the District of Nassau.¹⁵

In 1791, a portion of Quebec, including the new districts, was separated to establish the Province of Upper Canada. Newly appointed Lieutenant Governor John Graves Simcoe named Augustus Jones Provincial Land Surveyor and directed him to travel west from the Niagara River to survey and lay out Townships.¹⁶ In 1792 Treaty No. 3, the Between the Lakes Purchase, was negotiated between the Crown and the Mississaugas, giving Upper Canada ownership and access to a vast swath of land between Lake Erie and Lake Ontario.¹⁷ The final component of Jones' initial survey was the Township of Geneva, four concessions along the broken front of Lake Geneva, now known as Burlington Bay. Geneva's concessions were surveyed from the "Indian Point", a line which divided the lands to the west purchased by the crown, and the lands to the east still claimed by the Mississaugas. Initially set out for refugees of the French Revolution (1787-1799), an additional 10 concessions were surveyed to the north of Geneva and amalgamated with the Township and the lands surrounding the town of Dundas to form the Township of Flamborough in 1793.¹⁸

¹¹ Noble, "The Neutral Confederacy."

¹² "Upper Canada Land Surrenders and the Williams Treaties (1764-1862/1923)," *Government of Canada*, last modified February 15, 2013, <https://www.rcaanc-cirnac.gc.ca/eng/1360941656761/1544619778887#uc>.

¹³ "Upper Canada Land Surrenders," *Government of Canada*.

¹⁴ "Upper Canada Land Surrenders," *Government of Canada*.

¹⁵ Wray, Wray, Green and Green, ...and they came to East Flamborough, 1-3.

¹⁶ Wray, Wray, Green and Green, ...and they came to East Flamborough, 1-3.

¹⁷ "Upper Canada Land Surrenders," *Government of Canada*.; Donna Duric, "Between the Lakes Treaty No. 3 (1792)," *Mississaugas of the Credit First Nation*, last modified May 18, 2017, <http://mncfn.ca/treaty3/>.

¹⁸ Wray, Wray, Green and Green, ...and they came to East Flamborough, 1-2.

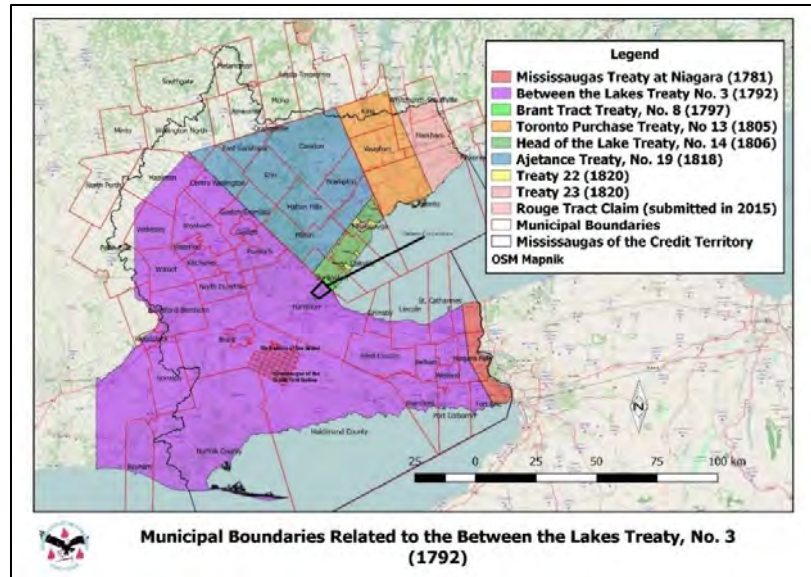

Figure 3: Geneva concessions as illustrated on a map of the treaties with the Indigenous from the Mississaugas of the Credit First Nation webpage

Construction began in 1793 on a highway commissioned by Lt. Governor John Simcoe, which initially ran westward from Burlington Bay to Joseph Brant's village on the Grand River.¹⁹ Subsequently, the previously established Land Board began accepting applications for property grants in Flamborough, awarding land mostly to members of the military and government officials who typically remained absentee landlords.²⁰ In 1796, Lieutenant Alexander McDonnell was awarded approximately 3000 acres including Lots 6 and 7 of Concession 3, the location of the original village core of Waterdown.²¹ Following boundary realignments and territorial renaming within Upper Canada between 1793 and 1798, the Township of Flamborough was split into the Townships of East and West Flamborough in 1798.²²

McDonnell's land went undeveloped and 800 acres were acquired by Alexander Brown in 1805, who then established the area's first sawmill above the Great Falls at Smokey Hollow and the Grindstone Creek.²³ That same year, Treaty No. 14, the Head of the Lake Treaty, was negotiated and the Crown acquired Mississauga lands east of East Flamborough, allowing for the easterly expansion of Lt. Governor Simcoe's highway, which would become Provincial Highway 5 and Dundas Street in Waterdown.²⁴ While

¹⁹ Sylvia Wray, *Dundas Street, Waterdown, 1793-1993* (Waterdown, ON: The Waterdown-East Flamborough Heritage Society, 1994), 3.

²⁰ Wray, Wray, Green and Green, *...and they came to East Flamborough*, 2-3.

²¹ Wray, Wray, Green and Green, *...and they came to East Flamborough*, 2-3.; Unterman McPhail Cuming Associates and Wendy Shearer Landscape Architect Limited, *Waterdown Heritage Conservation District Study: Heritage Assessment Report* (1996), 2-1.; Woods and Woods, *The Mills of Waterdown*, 20.

²² Wray, *From West Flamborough's Storied Past*, 4.

²³ Wray, Wray, Green and Green, *...and they came to East Flamborough*, 18.; Woods and Woods, *The Mills of Waterdown*, 21.

²⁴ Wray, *Dundas Street*, 4; Wray, Wray, Green and Green, *...and they came to East Flamborough*, 3.; Donna Duric, "Head of the Lake, Treaty No. 14 (1806)," *Mississaugas of the Credit First Nation*, last modified May 28, 2017, <http://mncfn.ca/head-of-the-lake-purchase-treaty-14/>.

previously difficult to access and largely untouched, the road and potential for water power made settlement in East Flamborough appealing to many, and slowly settlement and associated industry increased throughout the early 19th century.²⁵

Lieutenant Governor Simcoe's highway was a response to concerns about surprise attacks from the newly liberated American colonies and was intended to serve as a military passage for the movement of troops and supplies. Its secondary purpose was a means of encouraging settlement; however, construction did not begin until Simcoe's decision to move the capital to present day London. The first section of it, which became known as The Governor's Road, stretched from Burlington Bay to the Grand River. The second section was intended to extend the road to London, but Simcoe changed the location of the capital to York (modern day Toronto) causing construction to cease and nature to retake their hard work. Land grants were offered along this strip of highway with the stipulation that owners were required to keep the roadway clear. Work on the trail from Dundas began immediately following the movement of the capital but the second section of it, which stretched from Burlington Bay to York, was not started until a decade later due to the success of water transportation along Lake Ontario. This road from Dundas to York was named the Dundas Highway in honour of Henry Dundas, the Home Secretary responsible for Colonial Affairs. This roadway began as an Indigenous trail before being turned into a highway serving an important role in the history of both Waterdown and Ontario.²⁶

In 1823, Ebenezer C. Griffin arrived in the area, having previously purchased the majority of Concession 3, Lot 7 from Alexander Brown.²⁷ He established a number of businesses, including a store at the corner of Mill and Dundas Street, a flour mill above the Great Falls, and a carding mill on Mill Street South.²⁸ The area came to be known as Waterdown, and in 1831 Griffin prepared a village plan which became known as the Griffin Survey and began to sell off lots.²⁹ Settlement had begun along Dundas Street before his survey was finished particularly along what is known as Vinegar Hill, one of the oldest residential neighbourhoods of the village. This area is at the eastern entrance to Waterdown and is believed to be named after the smell from the fermentation of apples to create vinegar, which took place along this stretch of road where orchards were reportedly prevalent.³⁰ According to the 1841 assessment rolls, the majority of the almost fifty households in the Village were located in this area resulting in the formation of the Union Cemetery within this neighbourhood. In 1836, E.C Griffin sold his mill operations, at what would become known as Smokey Hollow, to George Abrey and John Heywood. In 1837, E.C. Griffin received a grant to Concession 3, Lot 6.³¹

²⁵ Wray, Wray, Green and Green, *...and they came to East Flamborough*, 18.

²⁶ Wray, *Dundas Street*, 3-5.

²⁷ Woods and Woods, *The Mills of Waterdown*, 44.

²⁸ Woods and Woods, *The Mills of Waterdown*, 44-46.

²⁹ Woods and Woods, *The Mills of Waterdown*, 50-54.; Wray, Wray, Green and Green, *...and they came to East Flamborough*, 18.

³⁰ Wray, *Dundas Street*, 8.

³¹ Woods and Woods, *The Mills of Waterdown*, 52.

In 1880, Griffin's General Merchant Store located on the southeast corner of Dundas and Mill Streets was sold to Joseph Culloden Eager. It remained in operation by the Eager family until its sale to the Weeks family in 1924.



Figure 4: Eager Store located on the southeast corner of Dundas and Mill Street, looking southeast to see the Eager House in the background, circa 1904; Source: Flamborough Archives, BW 71, Will Reid Collection

Subject Property – Block 25 Lot 12 (See Appendix E: Ownership History)

The subject property is part of Lot 6 Concession 3, which was granted by the Crown to E.C. Griffin in 1837. In 1845, twelve village lots totaling three of the original two hundred acres was sold to Daniel Reynolds who then sold the same village lots to George Abrey in 1852. With the settlement of Abrey's estate in 1871, Louisa Abrey sold these lots to James E. Eager (1842-1921) and his father Joseph C. Eager (1885-1948).³² The Eager family slowly leased and sold these lots until only the current lot of 0.34-acres remained. This lot of 0.34-acres remained as the Eager family home until 1989 when Helen Eager (1904-1989) died with no children of her own and her only surviving family members that had already established themselves outside of Waterdown, ending the family's ownership of the property.³³

³² Student Research for Heritage Society - Title Search: Eager House, Block 25, Lot 12, Conc. 3, 86.02.006, *Waterdown: Houses – The Eager House, 340 Dundas Street East*, Flamborough Archives (Waterdown).

³³ Flamborough Review - 17 May 1989 "Miss Helen Eager passes away: Family bought general store in 1880", 2005.12.307, *Vertical File: Eager Family*, Flamborough Archives (Waterdown).

According to the tax assessment records, the property was valued at \$1,600 in 1880 indicating that a significant structure was in existence. Since the available tax assessment records for Waterdown start in the year 1880, it is difficult to ascertain a precise construction date; however, considering the Eager family purchased the property in 1871 and Joseph C. Eager appeared to have commissioned architectural drawings (see **Appendix F: Primary Documents**) for the building, it is estimated that the house was built between 1871 and 1880.³⁴ These architectural drawings depict the proposed plan for construction, including the interior layout and exterior facades, as drawn by Hamilton architect William Leith. The drawings are not dated and the report accompanying it, which details the materials, measurements and methods of construction to be used, does not indicate if Joseph Eager requested any alterations to the purposed plan resulting in the current dwelling that does not exactly match the drawings. Considering William Leith's life span of 1835 to 1880 and his other work within Flamborough at this time, these drawings do fit into his career.

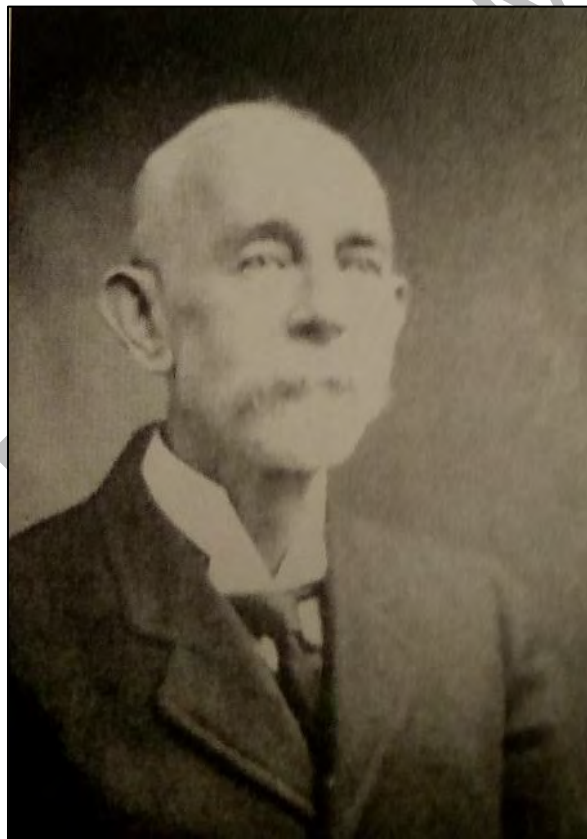

Figure 5: Photograph of James E. Eager; Source: The Mills of Waterdown, page 106 (photograph provided by his daughter Helen Eager)

³⁴ William Leith, *Design of a Dwelling House for J.C. Eager, Esq.*, 93.08.086, Map Cabinet Drawer #10, Flamborough Archives (Waterdown).

3.3 Contemporary Context

The subject property is located on the southwest corner of Dundas Street East and Reynold Street just east of the Dundas Street bridge of the Grindstone Creek. The immediate area on the north and south side of Dundas Street East features variably sized residential buildings that possess various setbacks, heights and styles, with tree cover and front facing landscaping.



Figure 6: Looking south down Reynold Street from Dundas Street East, showing the Eager House on the right (June 2018)

The property is also located within the historic residential area known as Vinegar Hill, generally described as Dundas Street between the Grindstone Creek to the west and First Street to the east, and north up to the Waterdown Union Cemetery and south to George Street. The area is primarily comprised of mid-nineteenth to early-twentieth century dwellings with some contemporary residential infill. Historic properties in the area include the Eager House (340 Dundas Street East, c. 1871), the Raycroft Cottage (348 Dundas Street East, c. 1860), the Pille House (353 Dundas Street East, c. 1879), Bramwell (356 Dundas Street East, c. 1876), the Kirby House (365 Dundas Street East, 1870), the Reid House (8 Margaret Street, c. 1890) and Union Cemetery (c. 1830). Various interventions to widen Dundas Street have altered the character of the homes in Vinegar Hill as the front yards have been shortened and former decorative fencing, as shown in **Figure 7** below) removed.



Figure 7: Vinegar Hill, looking west down Dundas Street towards the bridge with the white fence of the Eager House on the left, circa 1907; Source; Flamborough Archives, BW 2810



Figure 8: Vinegar Hill, looking west down Dundas Street to the bridge (June 2018)

4. Property Description

The 0.34-acre property at 340 Dundas Street East is comprised of a two-storey single-detached stone building clad in stucco, situated on the southwest corner of Dundas Street and Reynold Street in the Vinegar Hill area of the former Village of Waterdown and the former Township of East Flamborough, within the City of Hamilton.

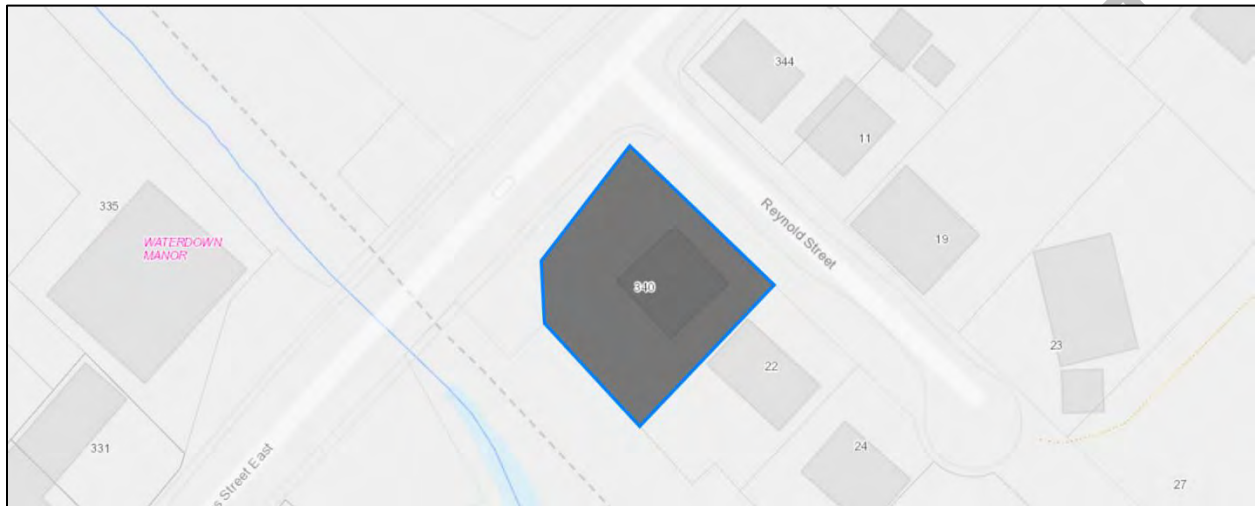

Figure 9: 340 Dundas Street East, highlighted in grey, City of Hamilton GISnet, 2019

4.1 Evolution of the Buildings and Landscape

The two-storey stone building clad with stucco has undergone few alterations since it was first constructed circa 1871. The 1939 Fire Insurance Plan of the Village (Figure 10) indicates that the property consisted of a two-storey dwelling fronting onto Dundas Street with a one-storey rear wing.

The most notable alterations that have taken place to the building, and its surroundings, include:

- Introduction of a wooden portico on the Dundas Street entrance (c. 1904);
- Parging of the exterior masonry, most likely with a rough cast lime cement finish (pre-1900s);
- Painting of the parged exterior (pre-1910s);
- Introduction of wooden shutters;
- Removal of all original chimneys, including both double chimneys, one on each projecting bay, and both single chimneys, one on the rear eastern bay and the other on the rear kitchen (20th century);

- Introduction of a single exterior chimney offset to the west of the building (mid-20th century);
- Removal of the finials on each of the gables of the projecting bays (20th century);
- Introduction of a small addition on the east façade of the rear kitchen (pre-1930s);
- Planting of a line of coniferous trees in the front yard (mid-20th century);
- Widening of Dundas Street and the adjacent bridge and removal of the decorative perimeter fencing in the front yard (mid-to-late-20th century);
- Introduction of a wooden privacy fence along Reynold Street and at the northwest corner near the bridge and the Grindstone Creek embankment (circa 2010); and,
- Introduction of extensive decorative gardens in the front yard including a row of daylilies along the Dundas Street sidewalk (late-20th to early-21st century).

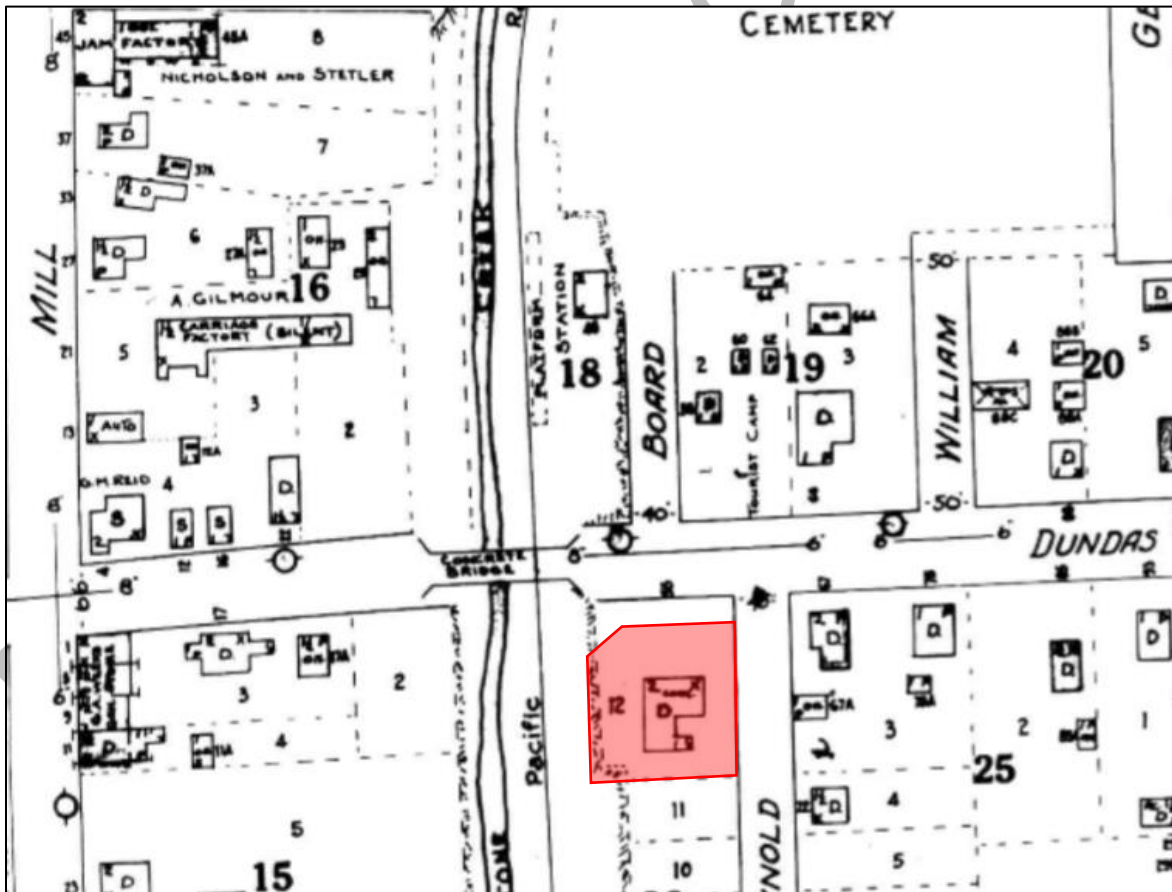

Figure 10: Insurance Plan of the Village of Waterdown, ON, May 1939, Excerpt of Sheet 1 (Existing property boundary of 340 Dundas Street East highlighted in red)

4.2 Building Description

The property is comprised of a two-storey, single-detached parged stone building believed to have been constructed around 1871 with a one-storey rear wing. The architect designed dwelling is influenced by the Gothic Revival architectural style, and key features include the:

- Rectangular footprint with flanking projecting front bays and rear wing;
- H-shaped gable roof with high pitched flanking projecting front and rear gables and off-set projecting side gables;
- Masonry construction with parged exterior;
- Decorative bargeboard under the front gables;
- Flat-headed window openings on the ground floor with one-over-one windows, four-pane wooden storms, plain lug stone sills and functional shutters;
- Semi-circular window openings in the second storey below the gables with one-over-one windows, two-pane wooden storms, plain lug stone sills and functional shutters;
- Small rectangular window opening above the front entrance between the flanking bays;
- Central entrance fronting onto Dundas Street with transom, sidelights and decorated wood panelling; and,
- Gable-roofed front porch ornately decorated with a wooden sun and ray detailing and supported by decorative wood columns atop a stone base with steps.



Figure 11: Eager House including front porch and windows, 1982; Source: Flamborough Archives, BW 269



Figure 12: Eager House including front porch and windows, 2018

5. Cultural Heritage Evaluation

The following is an evaluation of the cultural heritage value or interest of the subject property, in accordance with *Ontario Regulation 9/06* and the *City of Hamilton's Framework for Cultural Heritage Evaluation*.

The subject property has been evaluated against three sets of criteria – Archaeology, Built Heritage, and Cultural Heritage Landscapes – as follows:

5.1 Archaeology

Identified or potential archaeological resources can be considered as values meriting inclusion into the identified cultural heritage value for the designation of a property. A set of twelve criteria is used to evaluate an archaeological site or measure archaeological potential to determine what attributes, if any, warrant designation under Part IV of the *Ontario Heritage Act*.

The first eleven criteria for designation of an archaeological site are predicated on the presence of an archaeological site. In the case of 340 Dundas Street East, there are no registered or reported archaeological sites located on the subject property. As a result, only the Archaeological Potential criterion applies in this assessment.

Archaeological Criteria	
Cultural Definition: N/A	Site Setting: N/A
Temporal Integrity: N/A	Site Socio-political Value: N/A
Site Size: N/A	Site Uniqueness: N/A
Site Type: N/A	Site Rarity: N/A
Site Integrity: N/A	Site Human Remains: N/A
Historical Association: N/A	Archaeological Site Potential: Applicable

5.1.1 Archaeological Potential

The subject property is comprised of a two-storey building, situated in an historic urban context first developed in the late-nineteenth century. To be considered a site with archeological potential the property must meet at least one primary criteria or two secondary criteria for determining archaeological potential. The subject property is within the water catchment area of Grindstone Creek, meeting one primary criteria. The property is also within one hundred meters of an historic transportation corridor (Dundas Street), meeting one secondary criteria. The property has also experienced minimal disturbance. Therefore, this criterion is considered satisfied.

5.2 Built Heritage

A set of twelve criteria is used to identify and assess the built heritage value of a property. Of the twelve criteria, **ten** were applicable and satisfied for 340 Dundas Street East.

Historical Associations	Architecture and Design
Thematic: Applicable	Architectural Merit: Applicable
Event: N/A	Functional Merit: N/A
Person and/or Group: Applicable	Designer: Applicable
Integrity	Environmental Context
Location Integrity: Applicable	Landmark: Applicable
Built Integrity: Applicable	Character: Applicable
	Setting: Applicable
Social Value	
Public Perception: Applicable	

5.2.1 Historical Associations

Thematic

The property has direct associations with the themes of heritage preservation and village development. In 1871, Joseph C. and James E. Eager purchased this yet-to-be-developed land on the eastern edge of the village, later known as Vinegar Hill. The Eagers constructed a house on this property sometime between 1871 and 1880. As the village grew, the developed edge of the village was pushed further east. Despite the growth of the village, Vinegar Hill has remained residential despite its proximity to the downtown core, suggesting a resistance to development and the desire to maintain the residential use of the area. The relatively unchanged nature of the area, and the limited modifications to the Eager House, may be indicative of a focus on heritage preservation within the village, which has remained a prominent theme in the modern village context. Therefore, this criterion is considered satisfied.

Event

A specific event that has made a significant contribution to Waterdown, Ontario or Canada is not known to have occurred here.

Person/Group

The property has a direct association with the Eager family, specifically Joseph Culloden Eager (1809-1893), James Edward Eager (1842-1921) and Helen Eager (1904-1989). Joseph Culloden Eager was the son of Benjamin Eager and his second wife Rebecca Culloden who were Jacobites that moved from their native England to Ireland then to Upper Canada in 1837. The family settled in Lowville where Benjamin farmed, and Joseph started his career as a merchant before moving to Waterdown in the 1860s. The 1875 Wentworth County Atlas's Business Directory for East Flamboro' lists J.C. Eager & Son as farmers located on Dundas who settled in Waterdown in 1863. Joseph and James purchased the subject property in 1871 and, in 1880, they purchased the Griffin's General Merchant Store on the prominent southeast corner of Dundas and Mill Streets, located just west of the Eager House on the other side of the bridge over Grindstone Creek, and renamed it the Eager General Store. When Joseph

Culloden died in 1893, his son James took over the family home and continued operation of the family business. The Eager Store remained in the family for three generations before being sold to the Weeks family in 1924 who operated the store, later known as Weeks Hardware, until 1972. The Eager House remained in the family until the death of Helen Eager (1904-1989), daughter of James Edward Eager (her full name was Eliza Helen Feilde but she is referred to as Helen in all of the sources indicating her name preference), in 1989. She had no children of her own, her brothers and sisters predeceased her, and her niece and nephews had established themselves outside of Waterdown, so the property was sold ending the century-long legacy of the Eager family in Waterdown. Further research has the potential to yield information that contributes to a better understanding of the Eager Family's prominence in the village and their progression from a farming family to store owners and their ability to commission an architect to design their home.

5.2.2 Architecture and Design

Architectural Merit

The property is comprised of a two-storey parged stone architect-designed dwelling influenced by the Gothic Revival architectural style. It was constructed circa 1871 as a residence and has remained a dwelling throughout its history. The architectural merit of the building lies in its architectural features typical of, and influenced by, the Gothic Revival architectural style, including the: high pitched gables with decorative bargeboard; parged stone façades; central entrance with transom and sidelights; gable-roofed front porch with decorative sun and ray motif wooden detailing; flat-headed one-over-one windows with four-pane wooden storms and plain stone lug sills on the ground floor; and semi-circular windows with wooden storms and plain stone lug sills in the second storey below the gables. There is also high potential that some of the original interior features remain intact warranting further investigation, if given the opportunity.

The property exhibits a high degree of craftsmanship and artistic merit through the wood detailing including the decorative bargeboard and the ornate wood detailing on the front porch, an early addition. Therefore, this criterion is considered satisfied.

Functional Merit

The subject property was constructed as a residence circa 1871. It is a typical example of an vernacular stone structure, uses typical construction methods (such as exterior masonry parging) and does not possess any utilitarian features. Therefore, this criterion is not considered to be satisfied.

Designer

According to undated architectural drawings (see **Appendix F: Primary Documents**), the house was designed by Hamilton architect William Leith (1835-1880). Little is known about this particular architect beyond references to his business and work. *The Dictionary of Architects in Canada* indicates that Leith designed ecclesiastical,

institutional, commercial, industrial and residential buildings including: the MacNab Presbyterian Church Manse (116 MacNab Street South), Christ Church Sunday School (252 James Street North), Masonic Hall (96 James Street North), All Saints Church (15 Queen Street South), and a number of residential dwellings including a residence in West Flamborough (Lot 22, Concession 3) built in 1871, which appears to be non-extant. In the late 1870s, Leith was in a partnership with architect Lucien Hill. Together they designed an addition to the House of Providence in Dundas, a church in Tapleystown, a commercial block on King and James Streets (Hamilton), and an addition to the Central Fire Station on Hughson Street in Hamilton. It is possible that he was a member of the Leith family that resided in the Hermitage in Ancaster, but more research would need to be conducted to confirm this.

In addition, the portico was designed and constructed by well-known Waterdown contractor and carpenter John Reid (1854-1912), who was responsible for the construction of the Reid House (8 Margaret Street) and the McGregor House (49 Main Street North). He was the son of a weaver, William Reid, who arrived in Canada in 1830. John established himself as a builder and built himself a sawmill on the east side of Grindstone Creek, which was in operation until 1912 when the railroad was constructed. An excerpt from his workbook circa 1904 details the materials and labour required to construct and install the sun motif portico on the Eager House, which was commissioned by James Edward Eager (See **Appendix F**).

5.2.3 Integrity

Location Integrity

The building at 340 Dundas Street East remains in its original location. This fact is important since a historic building in its original location has greater cultural heritage value than one that has been moved from its original site. Therefore, this criterion is considered satisfied.

Built Integrity

Despite alterations, many of the original features of the building remain unchanged. Notable building features that appear to be original to the building and remain unaltered include the: stone construction, H-shaped gable roof with flanking projecting front bays with steep pitches and decorative bargeboard below; flat-headed and semi-circular windows with plain lug stone sills; and, central front entrance with transom and sidelights. The wooden portico on the front (north) entrance was a later addition to the house (circa 1900s); however, it appears to be unaltered and is now considered to be integral to the character of the building.

The interior of the building is presumed to be altered over time; however, there is potential that many of its original interior elements remain intact since the exterior of the building has been subject to few alterations. This warrants further investigation, if given the opportunity. Therefore, this criterion is considered satisfied.

5.2.4 Environmental Context

Landmark

The property is considered to be a local landmark. It is an important feature on Dundas Street marking the entrance to Vinegar Hill from the west and the transition from the commercial core of the village over the bridge into this historic residential area. Therefore, this criterion is considered satisfied.

Character

The section of Dundas Street east of the Grindstone Creek and west of First Street (Concession 6/7 line), known as Vinegar Hill, has historically been comprised of residential properties since the early development of the village in the mid-nineteenth century.

The property is important in defining the historic character of the area. The late-nineteenth century single-detached building defines the early residential character on the east end of Dundas Street and is visually and historically linked to its surroundings. The streetscape is characterized by buildings of both traditional (brick, wood, stucco) and modern (vinyl siding) building materials, heights ranging from one to two-and-one-half storeys, and eclectic architectural styles that demonstrate the development of the Village of Waterdown throughout its history. Therefore, this criterion is considered satisfied.

Setting

The property contributes to the character of Dundas Street, which features buildings of various ages and architectural influences. This section of Dundas Street includes one-to two-and-a-half storey buildings dating between the mid-nineteenth century to modern day. This property helps mark the transition from the historic commercial core of Waterdown to the west over the Dundas Street Bridge, to the modern subdivisions east of First Street. The shape of the property also reflects the angled northwest corner of the property that led to the historic Spring Street in the 19th-century, which travelled south parallel to Reynold Street towards the historic Water Street (non-extant). The widening of Dundas Street has altered the property and the character of Vinegar Hill as indicated in the historic photographs (see **Appendix C: Historical Images**). As is the case with all homes in Vinegar Hill fronting onto Dundas Street, the front yard was at one point larger, complete with decorative fencing. That fencing has since been removed and the yard shortened. The mid-twentieth century plantings of coniferous trees in the front yard may have been the Eager family's response to Dundas Street becoming a busier road.

The location of the Eager House in relation to the Eager Store is also significant. The former Eager Store, now the Waterdown Business Improvement Area Office at 5 Mill Street South, is still in its historic location just a few minutes walk from the house across the bridge over the Grindstone Creek. Also significant is the location of the house on the bank of the Grindstone Creek, a prime location especially during the boom of the milling

industry in Waterdown, that allowed Alfred (1905-1969) and Ted (1907-1956; full name was James Edward Benjamin) Eager, sons of James Edward Eager, to dam up the Grindstone Creek creating a swimming hole in their backyard. Therefore, this criterion is considered satisfied.

5.2.5 Social Value

Public Perception

Through its inclusion in various Waterdown specific histories and studies, the subject property has continued to demonstrate its value to the village.

The Eager House (340 Dundas Street East) was included in Sylvia Wray and Maurice Green's *Dundas Street Waterdown 1793-1993*, which documents the history of the main thoroughfare in the village. The history of the building and its occupants is outlined, and historic photographs included to showcase it as one of few significant residences that existed on Dundas Street during the indicated period.

The Eager House is also visible in a number of historic photographs of the village focused on the important crossing of Dundas Street over the Grindstone Creek (see **Appendix C: Historical Images**).

The subject property was included in a historic walking tour hosted by the Flamborough Archives, has been previously evaluated by the former Local Architectural Conservation Advisory Committee of Waterdown, as part of the Canadian Inventory of Historic Building (CIHB), and was evaluated by the Canadian Ministry of Transportation and Communications in 1983 as part of a report to determine the impact of the widening of Dundas Street between Evans and Sydenham Roads. In addition, there is an oral history of two of James Edward Eager's sons creating a swimming hole in their backyard by damming up the Grindstone Creek. Therefore, this criterion is considered satisfied.

5.3 Cultural Heritage Landscapes

A set of nine criteria is used to identify and assess the potential for a cultural heritage landscape. In the case of 340 Dundas Street East, the original transaction granting James E. Eager and Joseph C. Eager the property contained numerous other village lots that were later sold; however, the size of the property containing the family home (the subject property) has remained the same 0.34-acre sized lot. The subject property does contain mature trees and gardens, and is part of three identified landscapes, Dundas Street, Vinegar Hill and the Village of Waterdown, but on its own it is not considered to be a cultural heritage landscape. As a result, none of the Cultural Heritage Landscape criteria apply.

<i>Historical Associations</i>	<i>Scenic Amenity</i>
Thematic: N/A	Sense of Place: N/A
Event: N/A	Serial Vision: N/A
Person and/or Group: N/A	Material Content: N/A
<i>Integrity</i>	<i>Design</i>
Integrity: N/A	Design: N/A
<i>Social Value</i>	
Public Perception: N/A	

DRAFT FOR COMMENT

6. Cultural Heritage Value: Conclusions and Recommendations

6.1 Conclusions

The subject property possesses high archeological potential but does not satisfy any of the other eleven criteria indicated under the City's guidelines for archeology. In addition, the subject property is part of three identified landscapes, Dundas Street, Vinegar Hill and the Village of Waterdown, but on its own is not considered to be a cultural heritage landscape. As a result, none of the Cultural Heritage Landscape criteria apply. Therefore, the subject property is not considered to have heritage value worthy of designation according to those two categories. However, the subject property does satisfy **ten** of the twelve criteria pertaining to built heritage, including:

- Historical Associations:
 - Thematic
 - Person and/or Group
- Architecture and Design:
 - Architectural Merit
 - Designer
- Integrity:
 - Location Integrity
 - Built Integrity
- Environmental Context:
 - Landmark
 - Character
 - Setting
- Social Value:
 - Public Perception

6.2 Compliance with Ontario Regulation 9/06: Criteria for Determining Cultural Heritage Value or Interest

According to Subsection 1 (2) of *Ontario Regulation 9/06*, Criteria for Determining Cultural Heritage Value or Interest, a property may be designated under section 29 of the *Ontario Heritage Act* if it meets one or more of the following criteria:

- 1) The property has design value or physical value because it,
 - i) is a rare, unique, representative or early example of a style, type, expression, material or construction method,
 - ii) displays a high degree of craftsmanship or artistic merit, or
 - iii) demonstrates a high degree of technical or scientific achievement.
- 2) The property has historical value or associative value because it,
 - i) has direct associations with a theme, event, belief, person, activity, organization or institution that is significant to a community,
 - ii) yields, or has the potential to yield, information that contributes to an understanding of a community or culture, or
 - iii) demonstrates or reflects the work or ideas of an architect, artist, builder, designer or theorist who is significant to a community.
- 3) The property has contextual value because it,
 - i) is important in defining, maintaining or supporting the character of an area,
 - ii) is physically, functionally, visually or historically linked to its surroundings, or
 - iii) is a landmark.

The subject property has design value because it is a representative example of an architectural style and displays a high degree of craftsmanship and artistic merit; it has historical value because it has direct associations with a family significant to the community and demonstrates the work of a prominent architect and a builder who has significance to the community; and, it has contextual value because it is a landmark, important in defining the character of the area and is physically, functionally, visually and historically linked to its surroundings. The following is a summary of the cultural heritage value of the subject property according to *Ontario Regulation 9/06*:

6.2.1 Design / Physical Value

The property comprises a two-storey parged stone architect-designed dwelling influenced by the Gothic Revival architectural style. It was constructed as a residence between 1871, when the Eager family purchased the property, and 1880 when the tax

assessment records indicate the existence of a significant structure through its \$1,600 evaluation. The design value of the building lies in its architectural features typical of, and influenced by, the Gothic Revival architectural style, including the: high pitched gables with decorative bargeboard; parged stone façades; central entrance with transom and sidelights; gable-roofed front porch with decorative sun and ray motif wooden detailing; flat-headed one-over-one windows with four-pane wooden storms and plain stone lug sills on the ground floor; and semi-circular windows with wooden storms and plain stone lug sills in the second storey below the gables.

The physical value of the property also lies in its high degree of craftsmanship and artistic merit demonstrated by the decorative bargeboard and wood detailing on the front porch, including the sun and ray motif.

6.2.2 Historical / Associative Value

The historical value of the property lies in its direct association with the Eager family, an early local merchant family that operated a well-known general store in the village.

Joseph Culloden Eager (1809-1893) and his son James E. Eager (1842-1921) purchased the property in 1871 to build their family home and, in 1880, purchased Griffin's General Merchant Store to the west on the southeast corner of Dundas and Mill Streets and renamed it the Eager General Store. When Joseph Culloden died in 1893 his son James took over the family home and continued operation of the family business. The general store remained in the family for three generations before being sold to and continued by the Weeks family in 1924. The house remained in the family until the death of Helen Eager (born in 1904) in 1989 when the property was sold ending the more than a century long legacy of the Eager family in Waterdown.

The house demonstrates the work of architect William Leith of Hamilton and builder John Reid of Waterdown. The house is believed to have been designed by prominent Hamilton architect William Leith (1835-1880). He designed ecclesiastical, institutional, commercial, industrial and residential buildings throughout Hamilton including its historic surrounding areas including Dundas and Flamborough. The sun motif portico was a later addition designed and constructed by well-known Waterdown builder John Reid (1854-1912). He was the son of a weaver, William, who arrived in Canada in 1830. John established himself as a contractor and built himself a sawmill on the east side of Grindstone Creek, which he operated until 1912 when the railroad was constructed. John is responsible for other notable Waterdown buildings including the Reid House (8 Margaret Street) and The McGregor House (49 Main Street North).

6.2.3 Contextual Value

The 0.34-acre property is situated on the corner of Dundas and Reynold Streets, just east of the Dundas Street bridge, in the Village of Waterdown, in former East

Flamborough Township, within the City of Hamilton. The late-nineteenth century single-detached building defines the historic character of Dundas Street, as well as the area known as Vinegar Hill, and is visually and historically linked to its surroundings. The streetscape consists of buildings constructed both with traditional building materials (e.g. brick, wood and stucco) and modern building materials (e.g. vinyl siding) with heights ranging from one to two-and-a-half storeys and displaying an eclectic mix of architectural styles that demonstrate the development of the Village of Waterdown throughout its history. The character of Vinegar Hill and the size of the front lawns of the properties fronting onto Dundas Street have been altered due to the widening of the street resulting in smaller front yards and removal of the decorative fencing. It is believed that the planting of the coniferous trees in the front yard in the mid-twentieth century was the Eager family's response to the increased traffic from Dundas Street.

The property's location on the bank of the Grindstone Creek, a prime location particularly during the boom of the milling industry, and its close proximity to the extant Eager Store (now the Waterdown Village Business Improvement Area office), a few minutes walk from the house just over the bridge on Mill Street, are also significant to the contextual value of the Eager House. In addition, the shape of the property also reflects the angled northwest corner of the property that led to the historic Spring Street in the nineteenth century, which travelled south parallel to Reynolds Street towards the historic Water Street (non-extant).

6.3 Recommendation

The property located at 340 Dundas Street East, Waterdown satisfies the City of Hamilton evaluation criteria for properties of cultural heritage value, and the criteria established in *Ontario Regulation 9/06*. Therefore, the subject property warrants protection under the *Ontario Heritage Act* by designation and / or the negotiation of a heritage conservation easement agreement under the *Ontario Heritage Act*, in accordance with the following Description of Property, Statement of Cultural Heritage Value or Interest and Description of Heritage Attributes:

Description of Property

The 0.34-acre property at 340 Dundas Street East is comprised of a two-storey single-detached parged stone building located on the southwest corner of Dundas and Reynold Streets in the area known as Vinegar Hill in the Village of Waterdown, in the former Township of East Flamborough, within the City of Hamilton.

Statement of Cultural Heritage Value or Interest

The property located at 340 Dundas Street East, known as the Eager House, is comprised of a two-storey parged stone building constructed circa 1871. The historical value of the property lies in its association with the Eager family. Joseph Culloden Eager (1809-1893) and his son, James Edward Eager (1842-1921), purchased the property in 1871 and built the house sometime between 1871 and 1880. In 1880,

Joseph purchased Griffin's General Store on the corner of Dundas and Mill Streets and established the well-known Eager General Store. The general store was family-run for three generations before being sold to and continued by the Weeks family in 1924. The Eager House remained in the family until the death of Helen Eager (born in 1904), James Edward Eager's daughter, in 1989.

The associative value of the property also lies in its demonstration of the work of prominent Hamilton architect William Leith and local builder John Reid. William Leith (1835-1880) designed ecclesiastical, institutional, commercial, industrial and residential buildings throughout Wentworth County, including its historic surrounding areas such as Dundas and Flamborough. According to undated drawings, Joseph Culloden Eager commissioned William Leith to design the house. The ornate front porch was a later addition commissioned by James Edward Eager, designed and constructed by well-known Waterdown builder John Reid (1854-1912). John established himself as a contractor and built himself a sawmill on the east side of Grindstone Creek, which he operated until 1912 when the railroad was constructed. John is responsible for carpentry on other notable Waterdown buildings including the Reid House (8 Margaret Street) and The McGregor House (49 Main Street North).

The cultural heritage value of the property also lies in its design value as a representative example of an architect-designed dwelling influenced by the Gothic Revival architectural style, exemplified by the flanking projecting front bays with high pitched gables and decorative bargeboard. The property also demonstrates a high degree of craftsmanship and artistic merit, demonstrated by the ornately decorated front porch with wooden sun and ray detailing.

The contextual value of the property lies in its contribution to defining the historic character of Dundas Street, Vinegar Hill and the Village of Waterdown. The Eager House is physically, functionally, visually and historically linked to its surroundings, located on the south side of Dundas Street, east of the Grindstone Creek, marking the entrance to the area known as Vinegar Hill as you travel east up Dundas Street and out of the village. The Eager House is a recognizable local landmark situated on the Grindstone Creek, a prime location in the village, and only a few minutes walk away from the former Eager General Store on the southeast corner of Dundas and Mill Streets.

Description of Heritage Attributes

Key attributes that embody the heritage value of the property include the:

- Two-storey stone building, including its:
 - Masonry construction with parged exterior;
 - Rectangular footprint with flanking projecting front bays and one-storey rear wing;
 - H-shaped gable roof with high pitched flanking projecting front and rear gables and off-set projecting side gables;

- Decorative bargeboard under the front gables;
 - Flat-headed window openings on the ground floor with one-over-one windows, four-pane wooden storms, plain lug stone sills and functional shutters;
 - Semi-circular window openings in the second storey below the gables with one-over-one windows, two-pane wooden storms, plain lug stone sills and functional shutters;
 - Small rectangular window opening above the front entrance between the flanking bays;
 - Central entrance fronting onto Dundas Street with transom, sidelights and decorated wood panelling; and,
 - Gable-roofed front porch ornately decorated with wooden sun and ray detailing and supported by decorative wood columns atop a stone base with steps.
- Moderate setback from Dundas Street with front lawn and walkway to the front entrance.

Bibliography

Publications

- Chapman, L.J. and D.F. Putnam. *The Physiography of Southern Ontario*. Toronto: Ontario Ministry of Natural Resources, 1984.
- Green, Patricia, Maurice Green, Sylvia Wray and Robert Wray. *From West Flamborough's Storied Past*. Waterdown, ON: The Waterdown – East Flamborough Heritage Society, 2003.
- Mikel, Robert. *Ontario House Styles: The Distinctive Architecture of the Province's 18th and 19th Century Homes*. Toronto: Lorimer, 2004.
- Office of Archaeology and Historic Preservation. *Architectural Description Guide*. Olympia, WA: Office of Archaeology and Historic Preservation, 1978. Accessed <https://dahp.wa.gov/sites/default/files/ArchitecturalDescriptionGuide.pdf>.
- Page & Smith. *Illustrated Historical Atlas of the County of Wentworth*. Toronto: Page & Smith, 1875.
- Tidridge, Nathan. *The Extraordinary History of Flamborough: East Flamborough, West Flamborough & Waterdown*. Waterdown, ON: The Waterdown-East Flamborough Heritage Society, 2016.
- Unterman McPhail Cuming Associates and Wendy Shearer Landscape Architect Limited. *Waterdown Heritage Conservation District Study: Heritage Assessment Report*. 1996.
- Waterdown-East Flamborough Centennial Committee. *1867-1967: Waterdown and East Flamborough*. Waterdown, ON: Waterdown-East Flamborough Centennial Committee, 1967.
- Woods, Donald R. and Diane E. Woods. *The Mills of Waterdown: The Growth of an Ontario Village – 1790 to 1915*. Waterdown, ON: The Waterdown – East Flamborough Heritage Society, 2010.
- Wray, Sylvia, Robert Wray, Patricia Green and Maurice Green. *...and they came to East Flamborough: A Celebration of East Flamborough Township's pre-Confederation Heritage*. Waterdown, ON: The Waterdown-East Flamborough Heritage Society, 2015.
- Wray, Sylvia. *Dundas Street, Waterdown, 1793-1993*. Waterdown, ON: The Waterdown-East Flamborough Heritage Society, 1994.

Web Sources

Duric, Donna. "Between the Lakes Treaty No. 3 (1792)." *Mississaugas of the Credit First Nation*. Last modified May 18, 2017. <http://mncfn.ca/treaty3/>.

Duric, Donna. "Head of the Lake, Treaty No. 14 (1806)." *Mississaugas of the Credit First Nation*. Last modified May 28, 2017. <http://mncfn.ca/head-of-the-lake-purchase-treaty-14/>.

"Leith, William." *Dictionary of Architects in Canada 1800-1950*. <http://dictionaryofarchitectsincanada.org/node/1442>.

Noble, William C. "The Neutral Confederacy." *Canadian Encyclopedia*. Last modified October 16, 2018. <https://www.thecanadianencyclopedia.ca/en/article/neutral>.

"Upper Canada Land Surrenders and the Williams Treaties (1764-1862/1923)." *Government of Canada*. Last modified February 15, 2013. <https://www.rcaanc-cirnac.gc.ca/eng/1360941656761/1544619778887#uc>.

Maps

C. McMonies, *Plan of the Village of Waterdown County of Wentworth Ontario* [cartographic material], 1897.

Insurance Plan of the Village of Waterdown, Ont. 1939.

Village of Waterdown, County of Wentworth, Ontario [cartographic material]. Wentworth County Atlas Map, East Flamborough, Village of Waterdown, 1875.

Village of Waterdown, East Flamborough TWP. Imperial Atlas, 1903.

Winter, Henry. *Map of the Village of Waterdown, County of Wentworth* [cartographic material]. 1854.

Woods, Sidney W. *Plan of Survey of Lots as Shown on Registered Plan 355 O.L.S., 1967*. City of Hamilton Registered Plan 62M-008 registered December 27, 1973.

Historic Photographs

"340 Dundas Street East, August 2009, Waterdown." Google Streetview.

"340 Dundas Street East, May 2015, Waterdown." Google Streetview.

"340 Dundas Street East, July 2017, Waterdown." Google Streetview.

"340 Dundas Street East, April 2018, Waterdown." Google Streetview.

"340 Dundas Street East, June 2019, Waterdown." Google Streetview.

Photograph No. BW269. "Eager House." Flamborough Archives (Waterdown).

Photograph No. BW294. "Looking northeast to Board Street and the Eager House from Reid's planning mill on the banks of Grindstone Creek." Flamborough Archives (Waterdown).

Photograph No. BW342. "The Eager House." Flamborough Archives (Waterdown).

Photograph No. BW363. "West side Eager House." Flamborough Archives (Waterdown).

Photograph No. BW601. "Eager House Entrance." Flamborough Archives (Waterdown).

Photograph No. BW602. "Eager House Entrance." Flamborough Archives (Waterdown).

Primary Documents

Flamborough Review - 17 May 1989 "Miss Helen Eager passes away: Family bought general store in 1880", 2005.12.307. *Vertical File: Eager Family*. Flamborough Archives (Waterdown).

Leith, William. *Design of a Dwelling House for J.C. Eager, Esq.* 93.08.086, Map Cabinet Drawer #10. Flamborough Archives (Waterdown).

Student Research for Heritage Society - Title Search: Eager House, Block 25, Lot 12, Conc. 3, 86.02.006. *Waterdown: Houses – The Eager House, 340 Dundas Street East*. Flamborough Archives (Waterdown).

Appendix A: Location Map

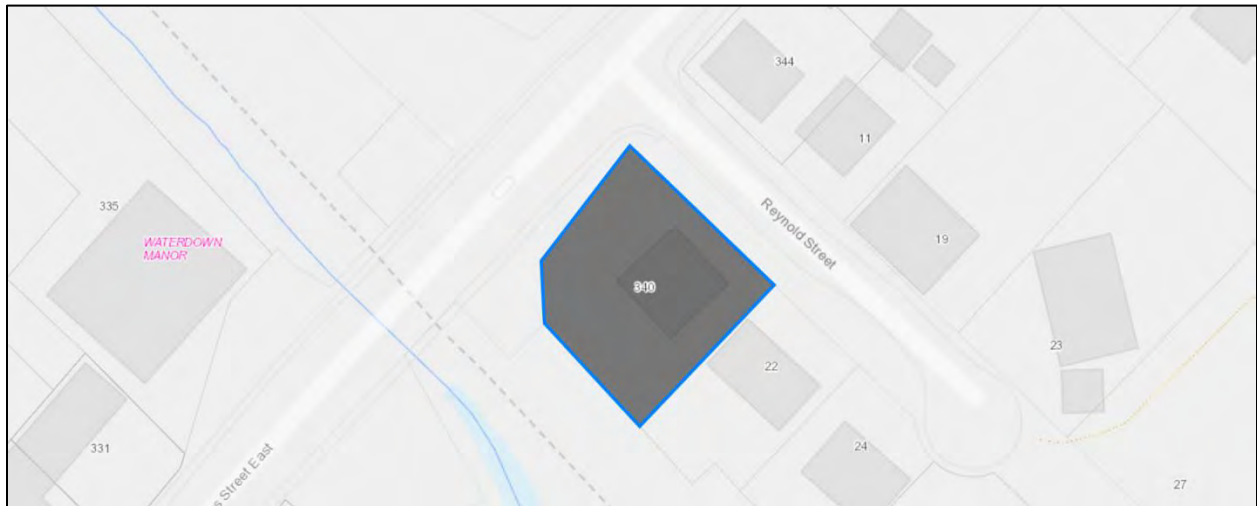

Figure 13: Map of subject property and surrounding area, City of Hamilton GISNet



Figure 14: Aerial view of subject property and immediate vicinity, City of Hamilton GISNet (2017)

Appendix B: Photographs



Image 1: View from Dundas Street



Image 2: View from Reynold Street



Image 3: View up the driveway from Reynold Street



Image 4: Corner of Dundas and Reynold Streets, looking southwest, August 2009, Waterdown; Source: Google Streetview



Image 5: Eager House, May 2015, Waterdown; Source: Google Streetview



Image 6: Eager House, July 2017, Waterdown; Source: Google Streetview



Image 7: Eager House, April 2018, Waterdown; Source: Google Streetview



Image 8: 340 Dundas Street East, June 2019, Waterdown; Source: Google Streetview

Appendix C: Historical Images



Image 9: Looking south to Board Street and the Eager House from Reid's planning mill on the banks of Grindstone Creek, Waterdown; Source: Flamborough Archives, BW 294



Image 10: Looking east across the Dundas Street Bridge into Vinegar Hill, showing the Eager House on the right, c.1900, Source: Flamborough Archives, BW 771



Image 11: Looking southeast across the Grindstone Creek to the Dundas Street Bridge and the Eager House, Waterdown; 1906-1910, Source: Flamborough Archives, BW 6



Image 12: Close-up of the Eager House, showing the former finials and chimneys and front yard fencing, 1906-1910, Source: Flamborough Archives, BW 6



Image 13: Vinegar Hill, looking west down Dundas Street towards the bridge, showing the front yard and white fencing of the Eager House on the left before the bridge, c. 1907, Source: Flamborough Archives, BW 2810



Image 14: Group of young Waterdown people on the Dundas Street Bridge, looking southeast with the Eager House in the background showing its front yard, fencing, front gable with round-headed windows and decorative bargeboard, c. 1911, Source: Flamborough Archives, BW 1903



Image 15: Eager House, Waterdown, north façade, 1982; Source: Flamborough Archives, BW 269, WAT.013



Image 16: West side Eager House, Waterdown, 1982; Source: Flamborough Archives, BW 363, WAT.013

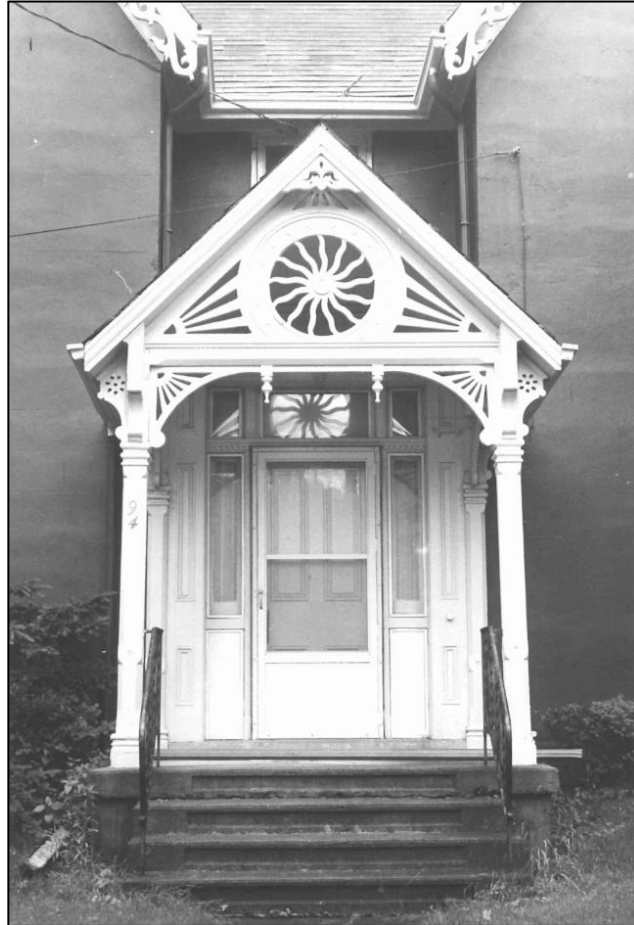

Image 17: Eager House front entrance, 1982, Waterdown; Source: Flamborough Archives, WAT.013



Image 18: Eager House front porch, Waterdown, 1982; Source: Flamborough Archives, WAT.013



Image 19: The Eager House, 1980, Waterdown; Source: Flamborough Archives, BW 342, WAT.013



Image 20: East (left) and west (right) sides of the Eager House, 1982; Source: Flamborough Archives, WAT.013



Image 21: West side of the rear wing of the Eager House, 1982; Source: Flamborough Archives, WAT.013



Image 22: Rear (south) of the Eager House showing the storm door to the basement and the rear wing, 1982; Source: Flamborough Archives, WAT.013



Image 23: Looking east over Dundas Street Bridge showing the widened road in front of the Eager House, 1993; Source: Flamborough Archives, BW 1114

DRAFT FOR CS

Appendix D: Plans and Mapping



Map 1: Map of the Village of Waterdown, County of Wentworth, August 26, 1854, Henry Winter, P.L. Surveyors (Excerpt showing approximate location of subject property highlighted in red)



Map 2: Wentworth County Atlas Map, East Flamborough, Village of Waterdown, 1875. (Excerpt showing approximate location of subject property highlighted in red)

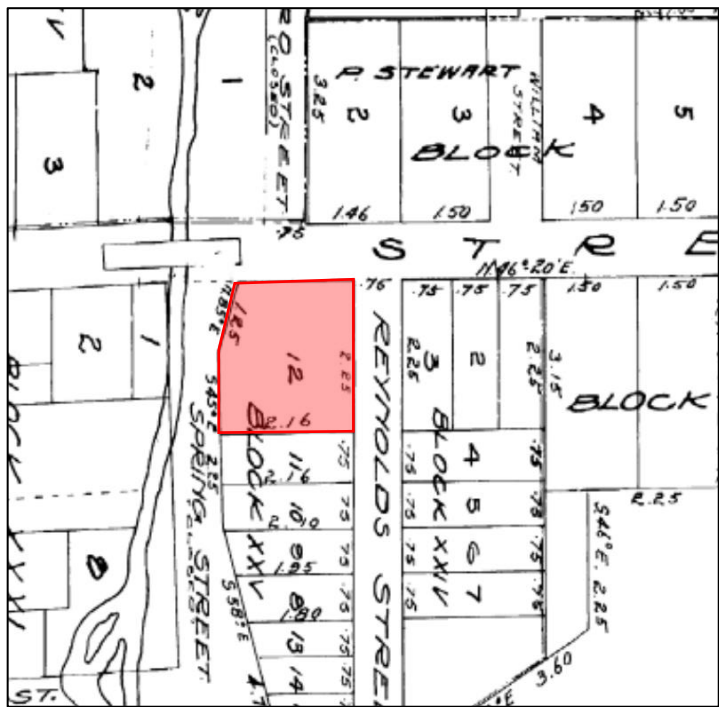

Map 3: Plan for the Village of Waterdown, 1897 (Excerpt showing approximate location of subject property highlighted in red)

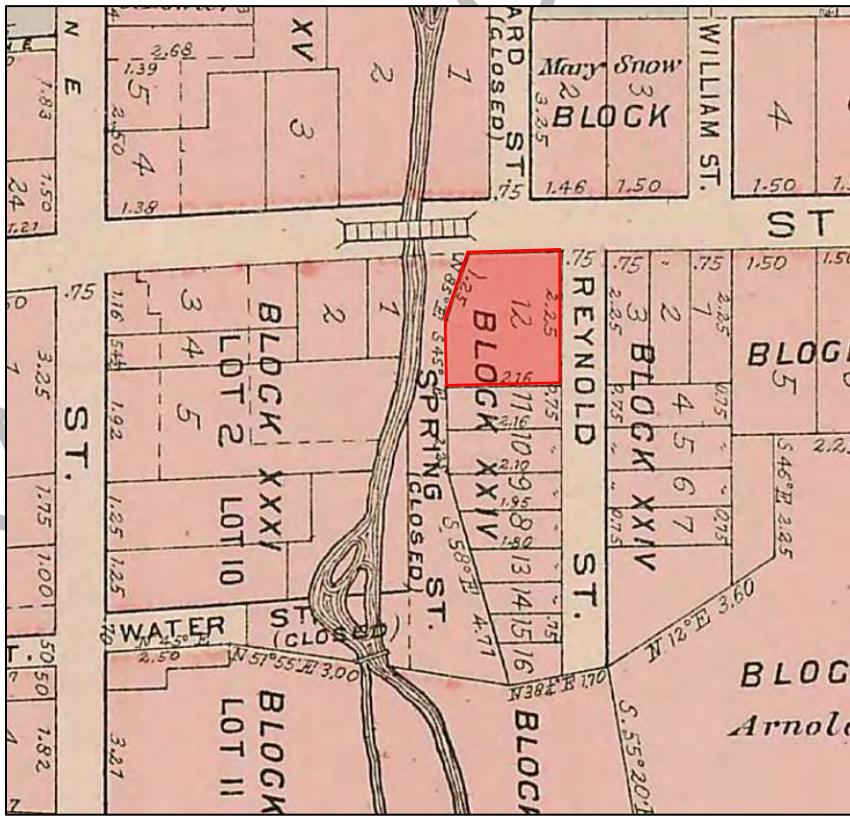

Map 4: 1903 Imperial Atlas page 17, Village of Waterdown (Excerpt showing approximate location of subject property highlighted in red)

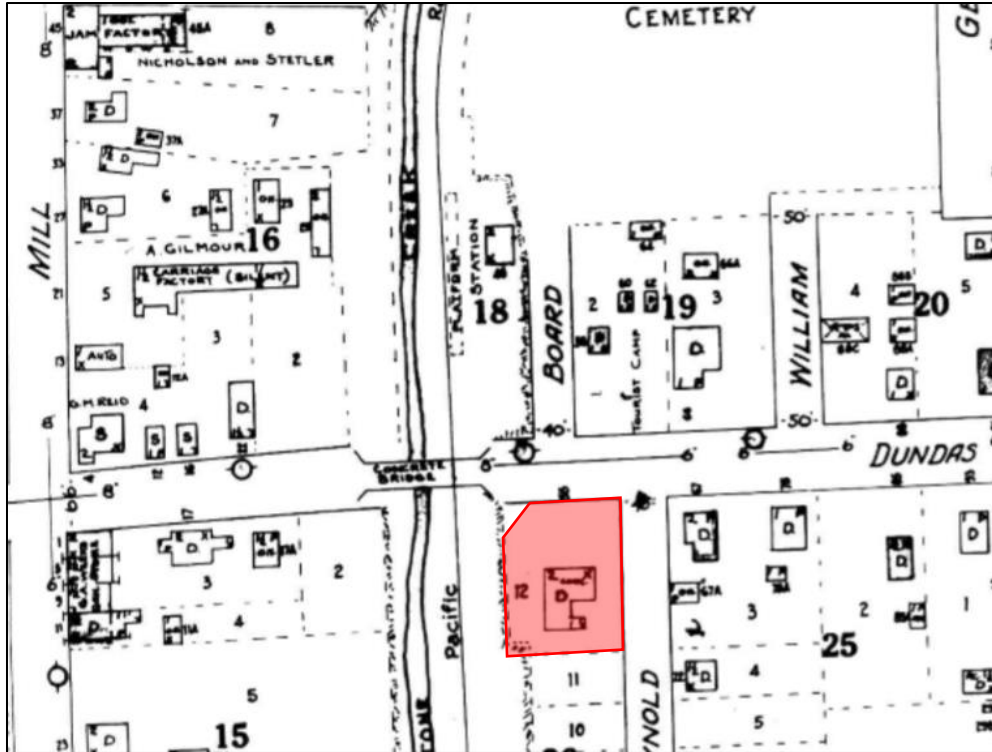

Map 5: Fire Insurance Plan for the Village of Waterdown 1939 (Excerpt showing approximate location of subject property highlighted in red)

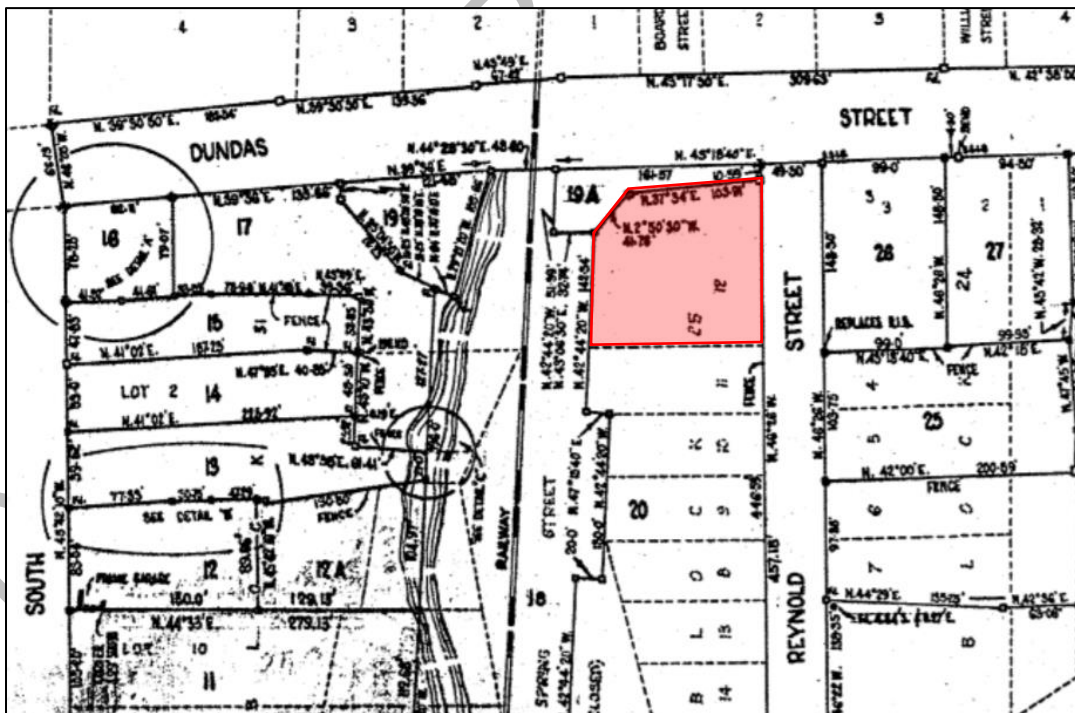

Map 6: Plan of Survey of Lots as Shown on Registered Plan 355, Sidney W. Woods, O.L.S., 1967. City of Hamilton Registered Plan 62M-010 registered December 27, 1973 (Excerpt showing approximate location of subject property highlighted in red)

Appendix E: Ownership History

Year	Name of Owner	Number of Acres
1836	The Crown	200
1837	E.C. Griffin	200
1845	David Reynolds	0.34
1852	George Abrey	0.34
1871	James E. and Joseph C. Eager	0.34
1960	Alfred Eager, Eliza Eager, Agnes Eager and Mary Tassie	0.34
1966	Alfred, Eliza and Agnes Eager	0.34
1978	Eliza Eager	0.34

Appendix F: Primary Documents

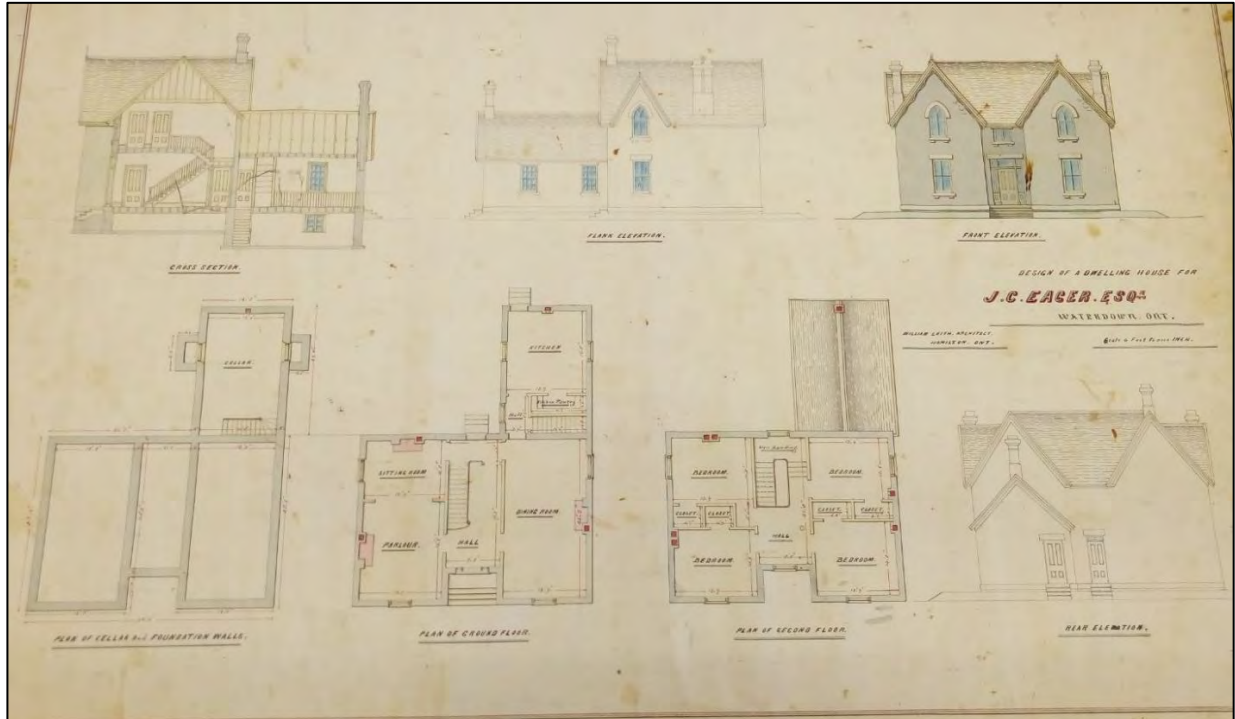

Image 24: Architectural Drawings of the Eager House by architect William Leith for James E. Eager, undated, Waterdown; Source: Flamborough Archives (93.08.086 - Map Cabinet Drawer #10) donated by the Planning Department of East Flamborough Township



Image 25: Excerpt of the Eager House Architectural Drawings featuring the Front Elevation



Image 26: Excerpt of the Eager House Architectural Drawings featuring the "Flank Elevation" (East Elevation)



Image 27: Excerpt of the Eager House Architectural Drawings featuring the Rear Elevation

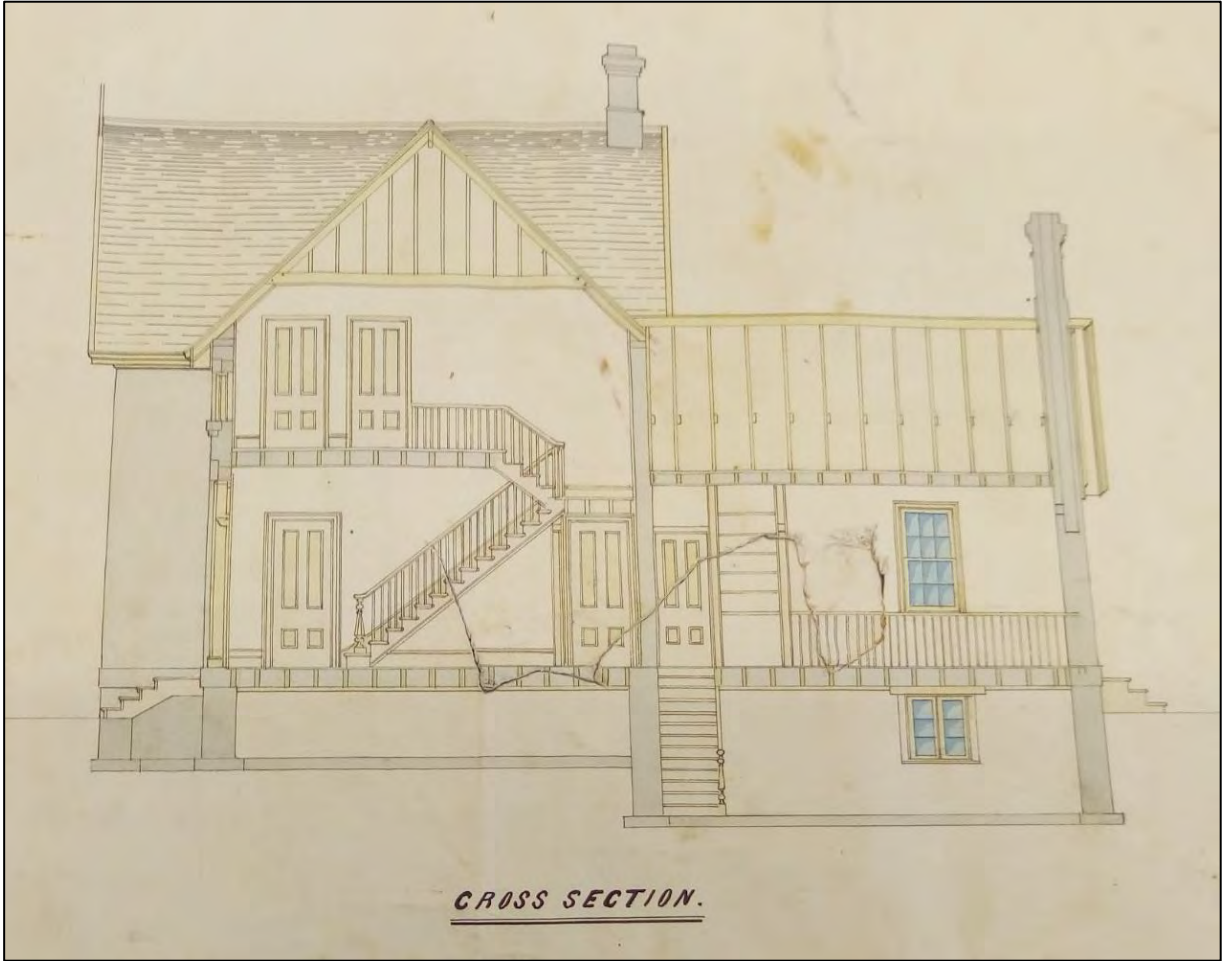

Image 28: Excerpt of the Eager House Architectural Drawings featuring the Cross Section

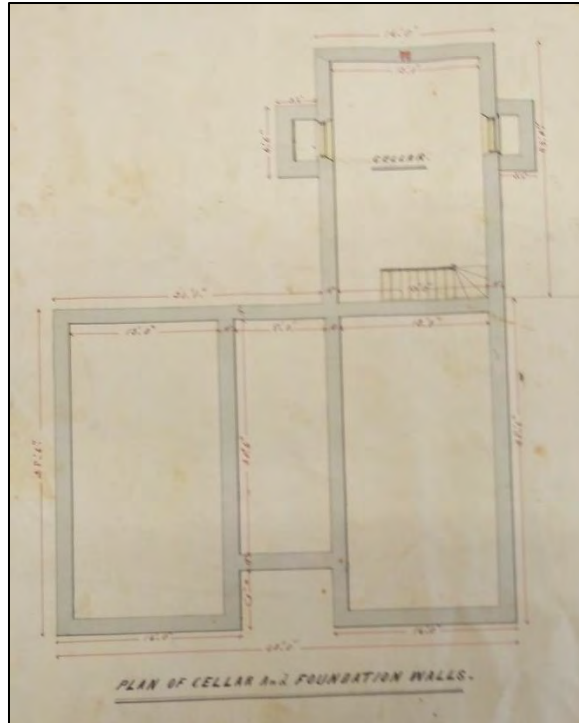

Image 29: Excerpt from the Eager House Architectural Drawings, Plan of the Cellar and Foundation Walls

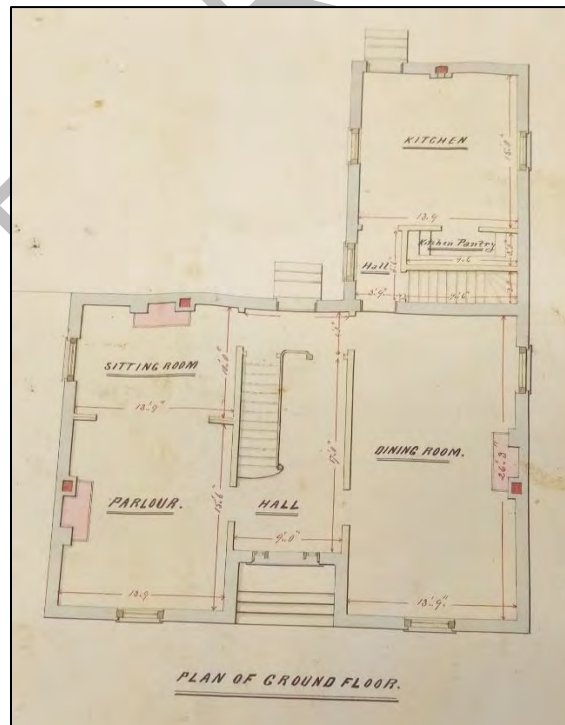

Image 30: Excerpt of the Eager House Architectural Drawings, Plan of the Ground Floor

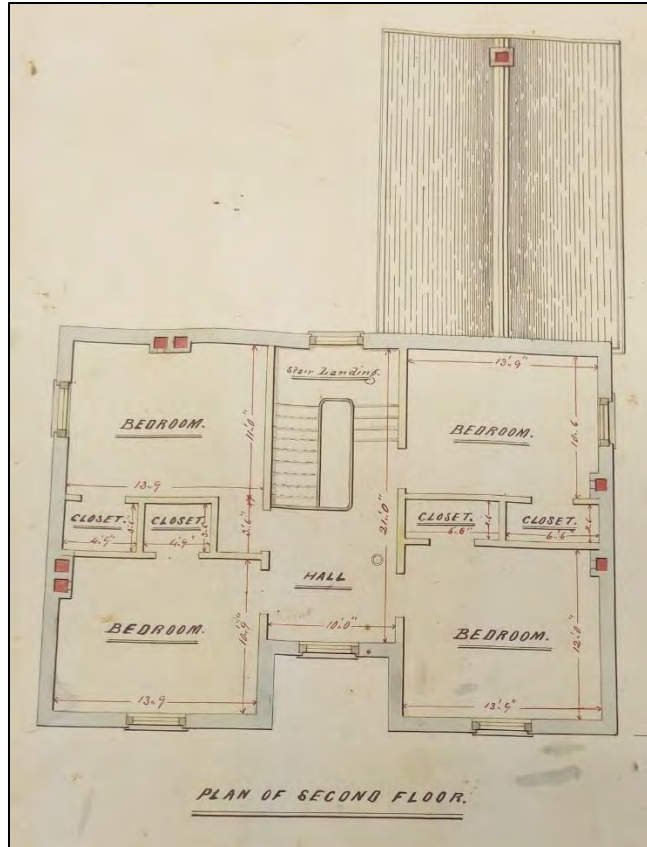

Image 31: Excerpt of the Eager House Architectural Drawings, Plan of the Second Floor

James Eagers porch	
100 ft of 1" dressed lumber	3.00
Front door with lock hinges + hanging	5.00
Side " " " " " "	5.00
Scantling	1.00
Sash + glass	3.00
Work + mouldings	8.00
	<u>25.00</u>

Image 32: Excerpt from local builder John Reid's Workbook for "James Eagers porch" for a total of \$25.00, circa 1904, Source: Flamborough Archives

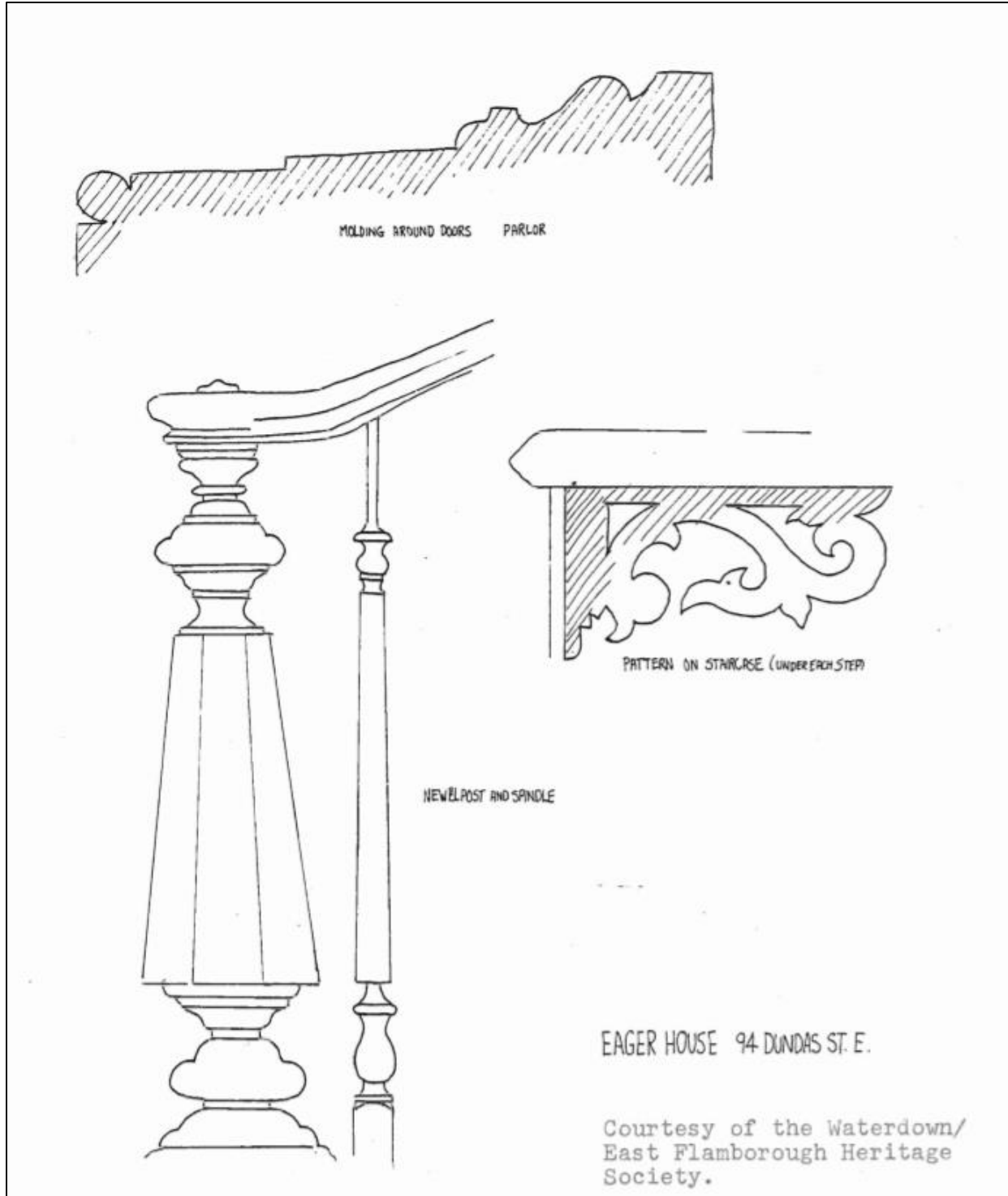

Image 33: Excerpt from the Town of Flamborough LACAC Research File, interior feature sketches, 1982, Source: Flamborough Archives WAT.013

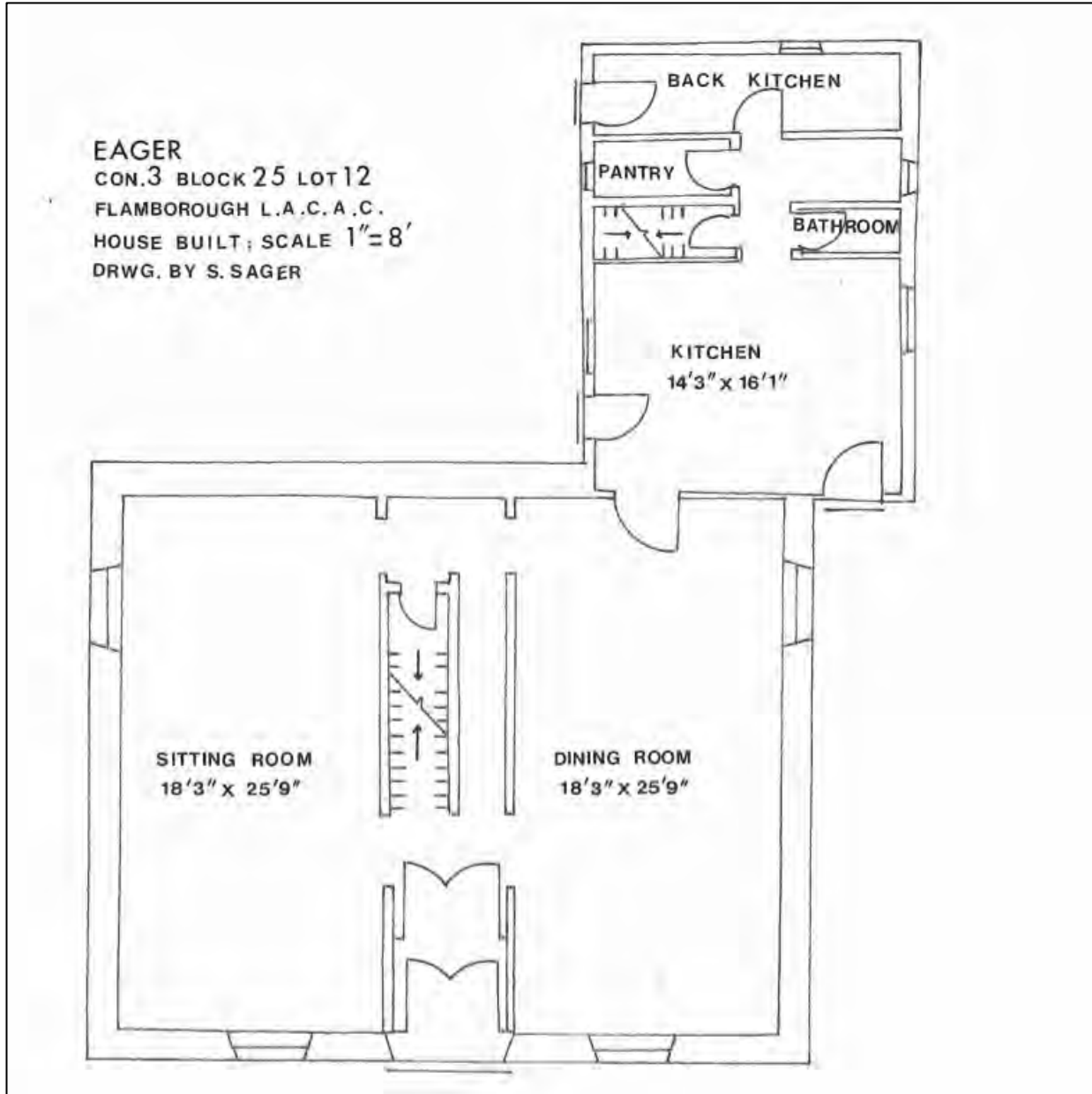

Image 34: Excerpt from the Town of Flamborough LACAC Research File, floor plan sketch, 1982, Source: Flamborough Archives WAT.013